



**FACSIMILE EQUIPMENT
SERVICE MANUAL**

**MODEL: FAX255/FAX275/
FAX355MC/FAX375MC/
FAX-515/FAX-525DT/
FAX-525MC/HOMEFAX3**

PREFACE

This publication is a Service Manual covering the specifications, construction, theory of operation, and maintenance of the Brother facsimile equipment. It includes information required for field troubleshooting and repair—disassembly, reassembly, and adjustment—so that service personnel will be able to understand equipment function, to rapidly repair the equipment and order any necessary spare parts.

To perform appropriate maintenance so that the facsimile equipment is always in best condition for the customer, the service personnel must adequately understand and apply this manual.

This manual is made up of six chapters and appendices.

CHAPTER I.	GENERAL DESCRIPTION
CHAPTER II.	INSTALLATION
CHAPTER III.	THEORY OF OPERATION
CHAPTER IV.	DISASSEMBLY/REASSEMBLY AND LUBRICATION
CHAPTER V.	MAINTENANCE MODE
CHAPTER VI.	ERROR INDICATION AND TROUBLESHOOTING
APPENDICES	EEPROM Customizing Codes & Circuit Diagrams

This manual describes the model and its versions to be destined for major countries. The specifications and functions are subject to change depending upon each destination.

CHAPTER I.

GENERAL DESCRIPTION

CHAPTER I. GENERAL DESCRIPTION

CONTENTS

1. EQUIPMENT OUTLINE	I-1
1.1 External Appearance and Weight	I-1
1.2 Components	I-1
2. SPECIFICATIONS	I-2

1. EQUIPMENT OUTLINE

1.1 External Appearance and Weight

The figure below shows the equipment appearance and approximate dimensions.

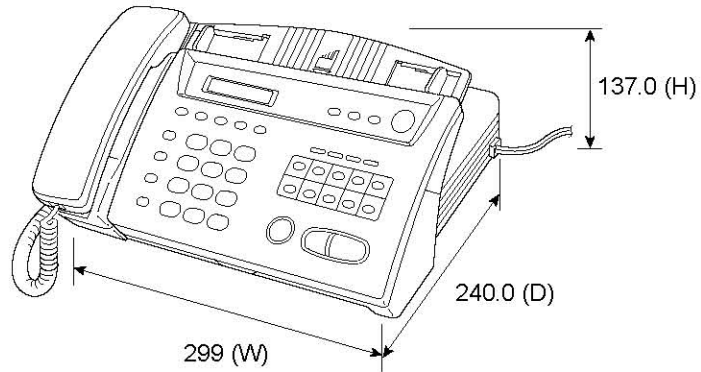

(Unit: mm)

Weight: Machine proper Approx. 2.9 kg (excluding a paper roll)
 In package Approx. 4.0 kg

1.2 Components

The equipment consists of the following major components:

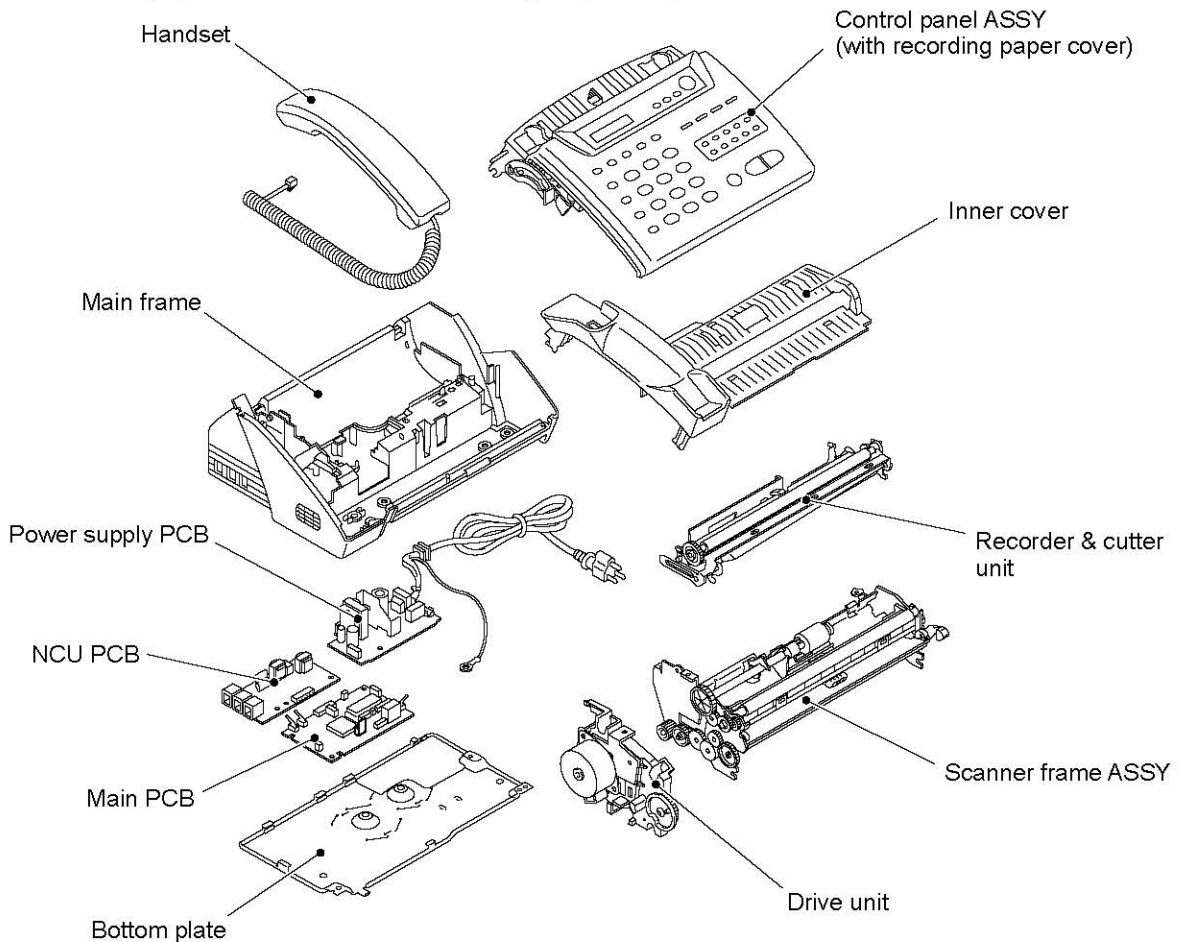

2. SPECIFICATIONS

Model	FAX255	FAX275
Color	Gray (1293)	White (1485)
Modem Speed	9600 bps	9600 bps
Coding Method	MH	MH
Transmission Speed	15 sec.	15 sec.
CCITT Group	G3	G3
Input/Output Width	Max. 8.5" x 8.5"	Max. 8.5" x 8.5"
Handset	Yes	Yes
Automatic Cutter	Yes	Yes
ADF Capacity (pages)	10	10
Anti-curl System	Yes	Yes
Roll Paper Size (Standard thermal/Therma PLUS)	164'/98' (1"-core)	164'/98' (1"-core)
LCD Size	16 x 1	16 x 1
On-screen Programming	Yes	Yes
Memory Capacity	No	No
Super Fine	Yes	Yes
Smoothing	Yes	Yes
Gray Scale (levels)	64 by Dithered Method	64 by Dithered Method
One-touch Dialing	10 locations	10 locations
Speed Dialing	10 locations	15 locations
Telephone Index	Yes	Yes
Super Telephone Index	No	No
Hook Key (TEL Key)	Yes	Yes
Fax/Tel Switch	Yes	Yes
TAD Interface	Yes	Yes
Enlargement/Reduction	No	No
Enhanced Remote Activation	Yes	Yes
Distinctive Ringing (FAX Ability)	Yes	Yes
Next-fax Reservation	No	Yes
Help	Yes, simple	Yes, simple
Caller ID (Caller Display)	Yes, w/ enhancement	Yes, w/ enhancement
Automatic Redialing	Yes	Yes
Auto Reduction	No	No
Multi-resolution Transmission	Yes	Yes
Polling	Yes (No secure polling)	Yes (No secure polling)
Delayed Transmission	Yes, 1 timer	Yes, 1 timer
Delayed Polling	No	No
Coverpage	No	No
Call Reservation	No	No
Call-back Message	No	No
Activity Report	No	No
Auto CNG Detection (New)	Yes	Yes
Transmission Verification Report	Yes, on LCD	Yes, on LCD
ECM	No	No
Broadcasting	No	No
Quick Scanning	No	No
Out-of-paper Reception	No	No
Multi Copy	No	No
Multi Transmission	No	No
PCI (Missing link)	No	No
Confidential Mailbox	No	No

Model	FAX355MC/FAX375MC	FAX-525DT/FAX-525MC
Color	White (1485)	Gray (1293)/White (1485)*
Modem Speed	14400 bps	14400 bps
Coding Method	MH	MH
Transmission Speed	9 sec.	10 sec.
CCITT Group	G3	G3
Input/Output Width	8.5"/8.5"	Max. 216/216 mm
Hold Key (Mute Key)	Yes	Yes
Automatic Cutter	Yes	Yes
ADF Capacity	10 pages	10 pages
Anti-curl System	Yes	Yes
Roll Paper Size (Standard thermal/Therma PLUS)	164/98' (1"-core)	50 m/30 m (1"-core)
LCD Size	16 x 1	16 x 1
On-screen Programming	Yes	Yes
Memory Capacity	512 KB	512 KB
Super Fine	Yes	Yes
Smoothing	Yes	Yes
Gray Scale (levels)	64 by Dithered Method	64 by Dithered Method
One-touch Dialing	10	10
Speed Dialing	50	50
Telephone Index	Yes	Yes
Super Telephone Index	No	No
Speaker Phone	Yes (Full Duplex)	Yes (Full Duplex)
Fax/Tel Switch	Yes	Yes
TAD Interface	Yes	Yes
Enlargement/Reduction	No	No
Enhanced Remote Activation	Yes	Yes
Distinctive Ringing (FAX Ability)	Yes	Yes for DEN/ARL/NZ
Next-fax Reservation	Yes	Yes
Help	Yes, simple	Yes, simple
Caller ID (Caller Display)	Yes, w/ enhancement	Yes for UK/NLD/SWE/NOR/ BEL/FRA/DEN/ARL/NZ
Automatic Redialing	Yes	Yes
Auto Reduction	No	No
Multi-resolution Transmission	Yes	Yes
Polling	Yes (No secure polling)	Yes (w/ secure polling)
Delayed Transmission	Yes, 1 timer	Yes, 3 timers
Delayed Polling	No	Yes
Coverpage	No	No
Call Reservation	No	No
Call-back Message	No	No
Activity Report	No	Yes
Auto CNG Detection (New)	Yes	Yes
Transmission Verification Report	Yes, on LCD	Yes, on LCD
ECM	Yes	Yes
Broadcasting	Yes	Yes
Quick Scanning	Yes	Yes
Out-of-paper Reception	Yes, 20 pages	Yes, 20 pages
Multi Copy	Yes	Yes
Multi Transmission	No	No
PCI (Missing link)	Yes	Yes
Fax Forwarding	Yes	Yes
Fax-on-demand	No	No
Fax Retrieval	Yes	Yes
ICM Recording Time	15 minutes	15 minutes
Memo/2-way Recording	Yes	Yes
Page Memory	Yes, 20 pages	Yes, 20 pages
Paging	Yes	Yes
Personal Fax Mail box (5)	No	No
Personal Voice Mail Box (5)	No	No
Remote Control	Yes	Yes
TAD Type	DSP type	DSP type
Toll Saver	Yes	Yes
Voice-on-demand	No	No

* FAX-525DT: Gray (1293)
FAX-525MC: White (1485)

Model	FAX-515	HOMEFAX3
Color	Gray (1293), White (1485)*	White (1485)
Modem Speed	9600 bps	9600 bps
Coding Method	MH	MH
Transmission Speed	15 sec.	15 sec.
CCITT Group	G3	G3
Input/Output Width	Max. 8.5" x 8.5"	Max. 8.5" x 8.5"
Handset	Yes	Yes
Automatic Cutter	Yes	Yes
ADF Capacity (pages)	10	10
Anti-curl System	Yes	Yes
Roll Paper Size (Standard thermal/Therma PLUS)	50 m/30 m (1"-core)	50 m/30 m (1"-core)
LCD Size	16 x 1	16 x 1
On-screen Programming	Yes	Yes
Memory Capacity	No	No
Super Fine	Yes	Yes
Smoothing	Yes	Yes
Gray Scale (levels)	64 by Dithered Method	64 by Dithered Method
One-touch Dialing	10	8
Speed Dialing	50	50
Telephone Index	Yes	Yes
Super Telephone Index	No	No
Hook Key (TEL Key)	Yes	Yes
Fax/Tel Switch	Yes	Yes
TAD Interface	Yes	Yes
Enlargement/Reduction	No	No
Enhanced Remote Activation	Yes	Yes
Distinctive Ringing (FaxAbility)	Yes**	Yes
Next-fax Reservation	Yes	Yes
Help	Yes, Simple	Yes, simple
Caller ID (Caller Display)	Yes***	Yes
Automatic Redialing	Yes	Yes
Auto Reduction	No	No
Multi-resolution Transmission	Yes	Yes
Polling	Yes	Yes
Delayed Transmission	Yes, 1 timer	Yes, 1 timer
Delayed Polling	Yes	Yes
Coverpage	No	No
Call Reservation	No	No
Call-back Message	No	No
Activity Report	Yes (15)	Yes
Auto CNG Detection (New)	Yes	Yes
Transmission Verification Report	Yes, on LCD	Yes, on LCD
ECM	No	No
Broadcasting	No	No
Quick Scanning	No	No
Out-of-paper Reception	No	No
Multi Copy	No	No
Multi Transmission	No	No
PCI (Missing link)	No, Yes****	No

* White (1485) only for the Australian versions

** Only for the Australian and Danish versions

*** Only for the U.K., Dutch, Norwegian, Belgium, French, Danish and Swedish versions

**** Yes only for the Australian versions

CHAPTER II.

INSTALLATION

CHAPTER III.

THEORY OF OPERATION

CHAPTER III. THEORY OF OPERATION

CONTENTS

1. OVERVIEW	III-1
2. MECHANISMS	III-2
2.1 Transmitting Mechanism (Feeding and scanning documents)	III-2
2.1.1 Automatic document feeder (ADF)	III-2
2.1.2 Scanner	III-3
2.2 Receiving Mechanism (Feeding recording paper and printing data)	III-4
2.2.1 Anti-curl system (ACS)	III-4
2.2.2 Automatic cutter	III-4
2.2.3 Recorder	III-4
2.3 Power Transmission Mechanism	III-5
2.3.1 Structure of the gear train	III-5
2.3.2 Description of planetary gear system	III-7
2.3.3 Power transmission for four operation modes	III-8
[1] Recording mode (Solenoid: OFF, Motor rotation: Forward)	III-9
[2] Scanning mode (Solenoid: OFF, Motor rotation: Reverse)	III-10
[3] Copying mode (Solenoid: ON→OFF, Motor rotation: Forward) ...	III-11
[4] Cutter driving mode (Solenoid: ON, Motor rotation: Reverse)	III-12
2.3.4 Power transmission route	III-14
2.4 Sensors and Actuators	III-15
3. CONTROL ELECTRONICS	III-17
3.1 Configuration	III-17
3.2 Main PCB	III-18
3.3 NCU PCB	III-20
3.4 Control Panel PCB	III-22
3.5 Power Supply PCB	III-23

1. OVERVIEW

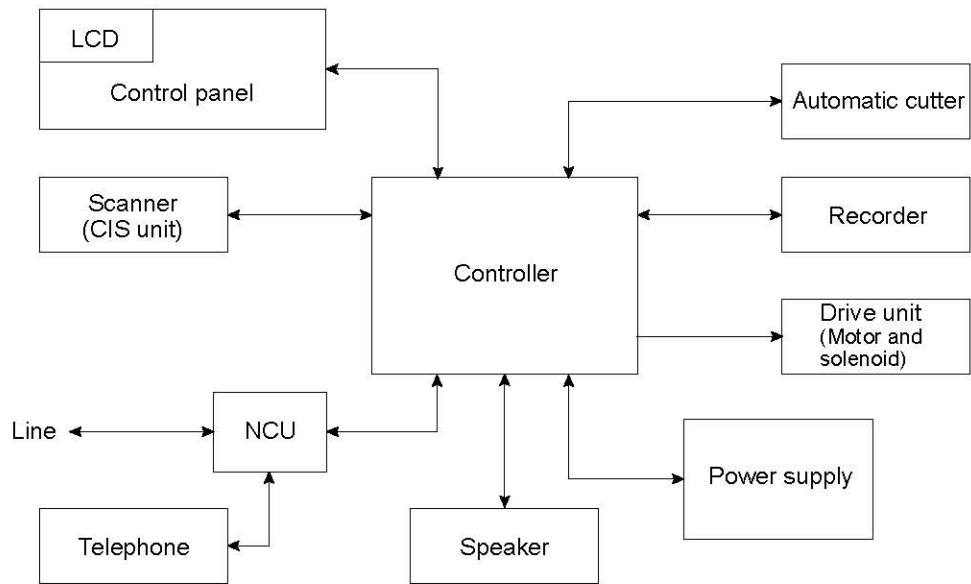

2. MECHANISMS

The equipment is classified into the following mechanisms:

- Transmitting Mechanism Feeding and scanning documents
- Receiving Mechanism Feeding recording paper and printing data
- Power Transmission Mechanism Switching the power transmission route
- Sensors and Actuators

2.1 Transmitting Mechanism (Feeding and scanning documents)

The transmitting mechanism consists of the document stacker, automatic document feeder (ADF), document feeding related rollers, scanner, and document sensors. (For details about the sensors, refer to Section 2.4.)

For the drive power source, refer to Section 2.3.

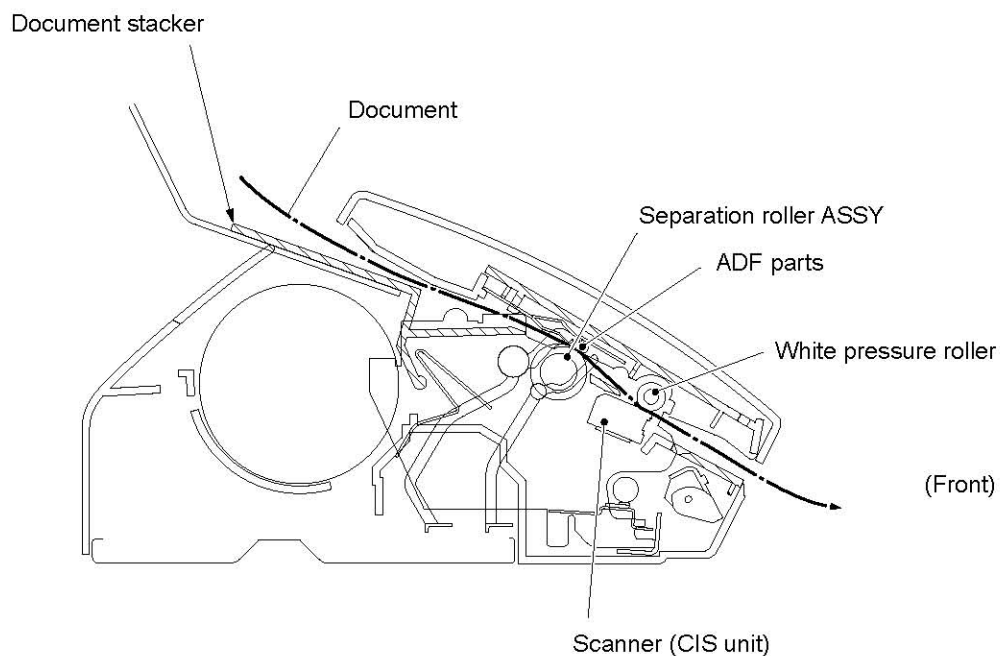

2.1.1 Automatic document feeder (ADF)

If the operator sets documents on the stacker and starts the transmitting operation, the ADF (consisting of the separation roller ASSY and ADF parts) feeds those documents into the equipment, starting from the bottom sheet to the top, page by page. Each document advances to the scanner, and then it is fed out of the equipment with the white pressure roller.

2.1.2 Scanner

The scanner uses a contact image sensor (CIS) unit which consists of an LED array illuminating documents, a self-focus lens array collecting the reflected light, a CIS PCB carrying out photoelectric conversion to output picture element data, and a cover glass on which a document advances. When the document passes between the white pressure roller and the cover glass, it is scanned.

2.2 Receiving Mechanism (Feeding recording paper and printing data)

The receiving mechanism consists of the recording paper roll holder, anti-curl system (ACS) plate, platen, thermal recording head, automatic cutter, and sensors. (For details about the sensors, refer to Section 2.4.)

The recording paper is routed on the ACS plate to the recording head which prints onto the heat-sensitive recording paper pressed by the platen according to received image signals. The printed paper is further fed through the cutter chute and cut by the automatic cutter page by page.

For the drive power source, refer to Section 2.3.

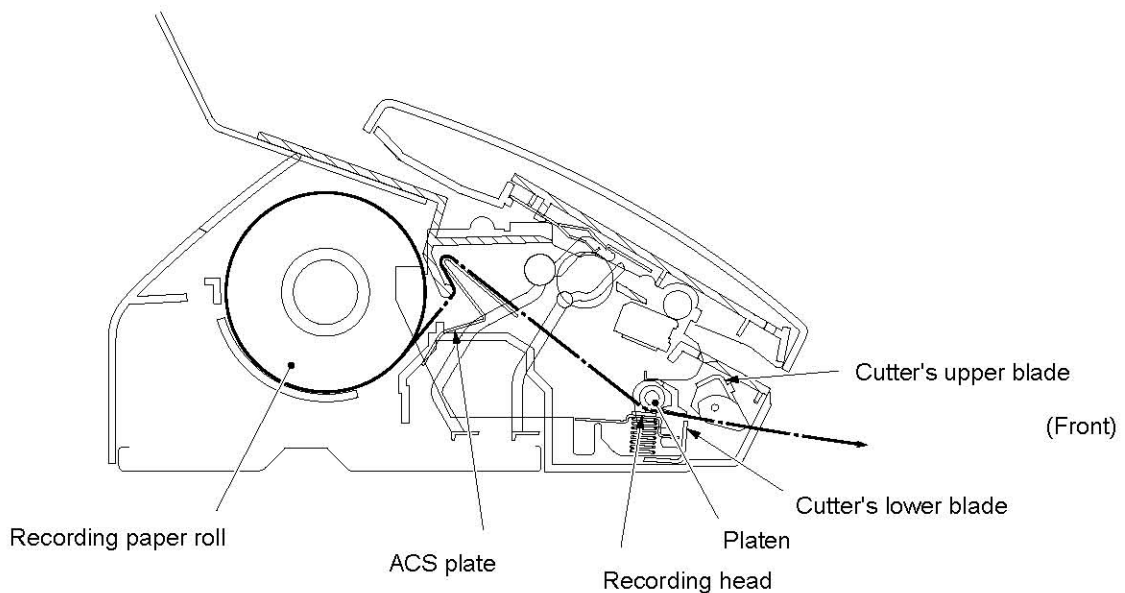

2.2.1 Anti-curl system (ACS)

The ACS eliminates curl peculiar to rolled recording paper by curving the paper towards the opposite side of the curl with the ACS plate.

2.2.2 Automatic cutter

The automatic paper cutter consists of an upper blade (rotary) and a lower blade (stationary). As the upper blade rotates around the left end hub, the recording paper will be cut. Upon completion of cutting, the upper blade returns to its home position which is detected by the cutter HP sensor.

2.2.3 Recorder

The recorder, which is incorporated in the middle of the machine, consists of the recording head unit, coil spring, and platen. It prints according to received image signals.

2.3 Power Transmission Mechanism

The equipment has a single drive motor whose power transmission route can be switched by the planetary gear train and the solenoid. This switching allows the equipment to function in four operation modes (recording, scanning, copying, and cutter driving modes).

2.3.1 Structure of the gear train

The gear train consists of two groups of gears: one group on the drive unit and the other on the scanner frame ASSY. Mounting the drive unit onto the scanner frame ASSY makes those two groups of gears engage with each other so that the rotation torque of the motor on the drive unit is transmitted to the separation roller, white pressure roller, and platen.

Shown below are a group of gears, the motor and solenoid on the drive unit. The cutter gear (Q) is integrated in the cutter flange (R) whose boss is placed in the hole provided in the cutter's upper blade.

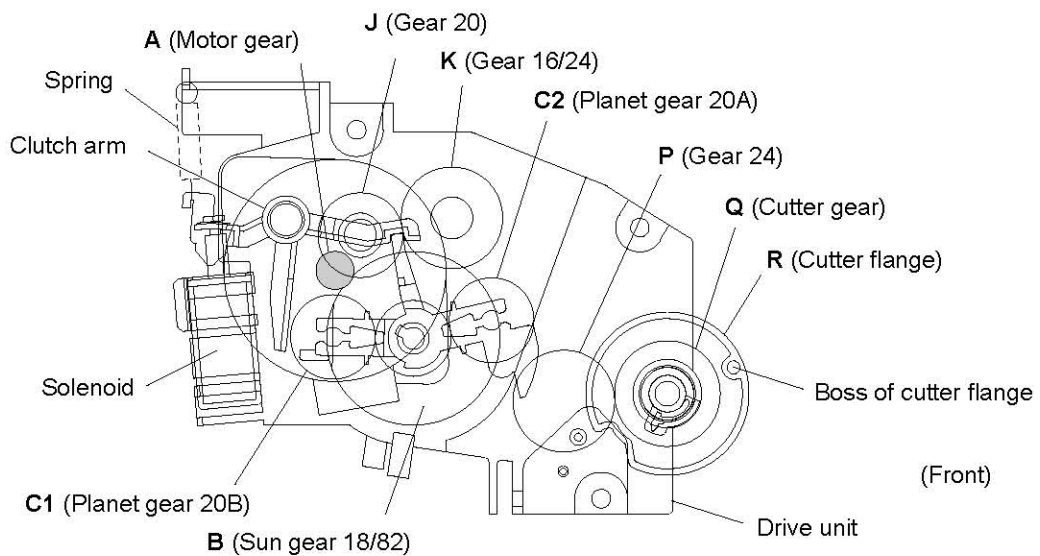

Drive Unit (viewed from the motor mounting side)

Shown below is a group of gears on the scanner frame ASSY.

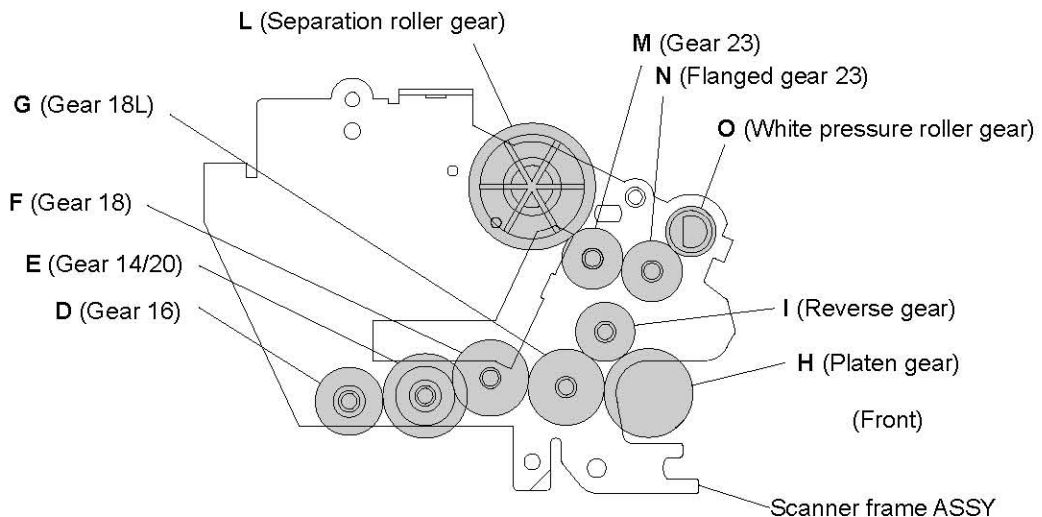

Scanner Frame ASSY

Shown below is a gear train constructed by combining the drive unit and scanner frame ASSY. The motor rotation is transmitted via the planet gear 20B (C1) to the gear 16 (D) and via the gear 16/24 (K) to the separation roller gear (L).

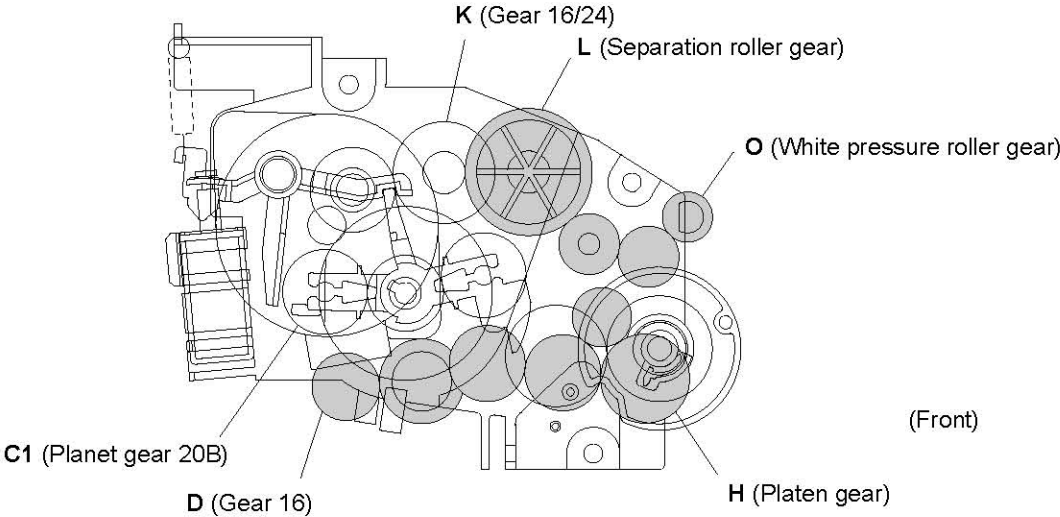

Combination of Drive Unit and Scanner Frame ASSY

2.3.2 Description of planetary gear system

The planetary gear train consists of the sun gear 18/82, two planet gears 20, arm A, and arm B, as shown below.

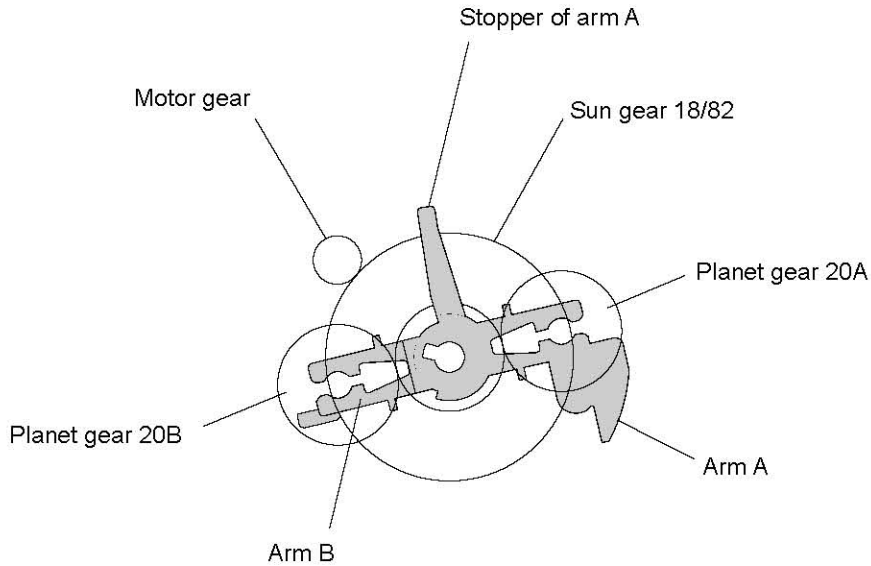

Planetary Gear System

If the motor rotates, the sun gear 18/82 rotates so that the rotational torque is transmitted to the engagement between the sun gear and the planet gears 20. Since the arms and planet gears are so designed that the moment of the arms is less than that of the planet gears, the arms turn around the center shaft in the same direction as the sun gear 18/82.

If the planet gear(s) becomes engaged with any other gear so that the arm cannot turn any more, the rotational torque of the sun gear 18/82 is transmitted to that planet gear. Accordingly, the planet gear starts rotation in the opposite direction of the sun gear 18/82.

2.3.3 Power transmission for four operation modes

Depending upon the solenoid ON/OFF state and the motor rotation direction, the planetary gear train switches the power transmission route for the four operation modes.

Solenoid ON/OFF state

Motor rotation direction

Solenoid: OFF

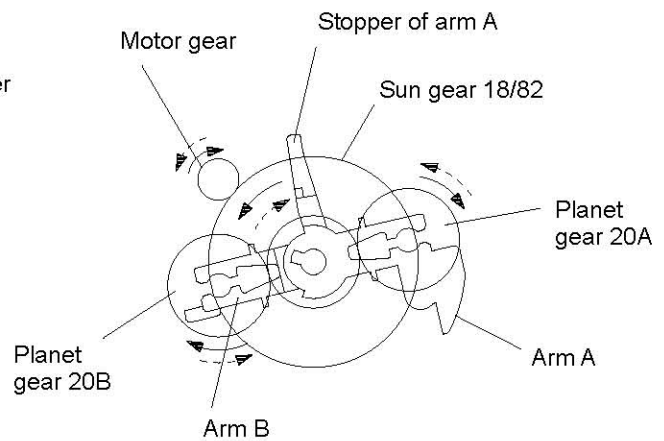
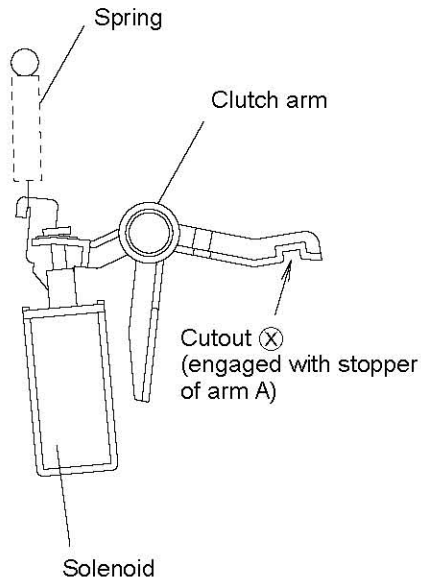

Solenoid: ON

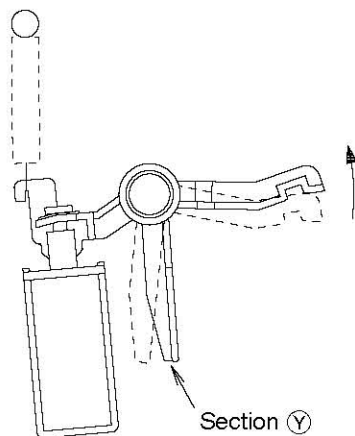

[1] Recording mode (Solenoid: OFF, Motor rotation: Forward)

In the recording mode, the control electronics deactivates the solenoid. When the motor rotates in the forward direction, the clutch arm turns clockwise with the spring and its cutout (⊗) becomes engaged with the stopper of arm A. Once arm A is locked, the planet gear 20A (C2) will not be engaged with any other gear but simply idle.

The motor rotation turns the sun gear 18/82 (B) counterclockwise so that the planet gear 20B (C1) transmits the rotation via the gears D through G to the platen gear (H).

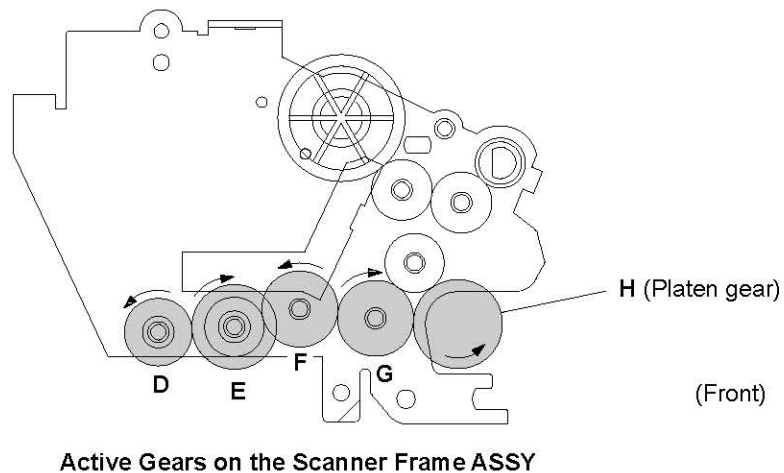
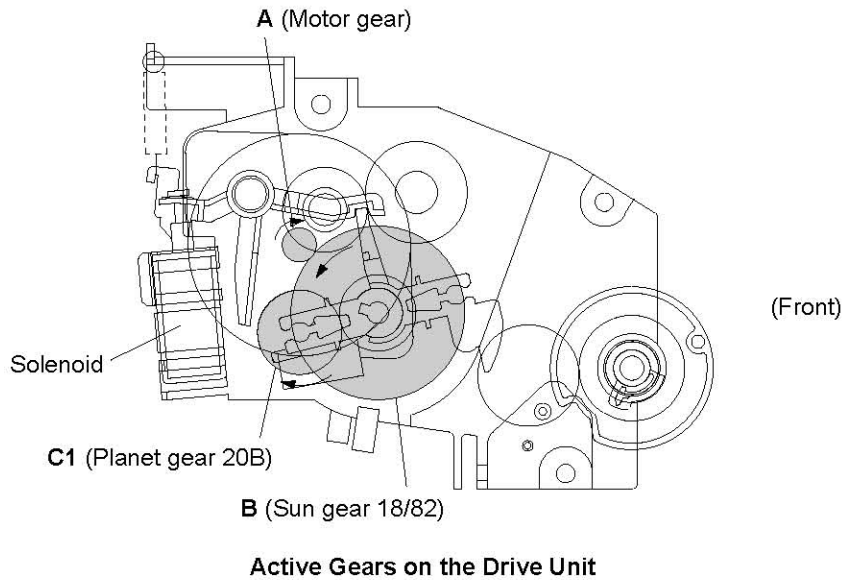
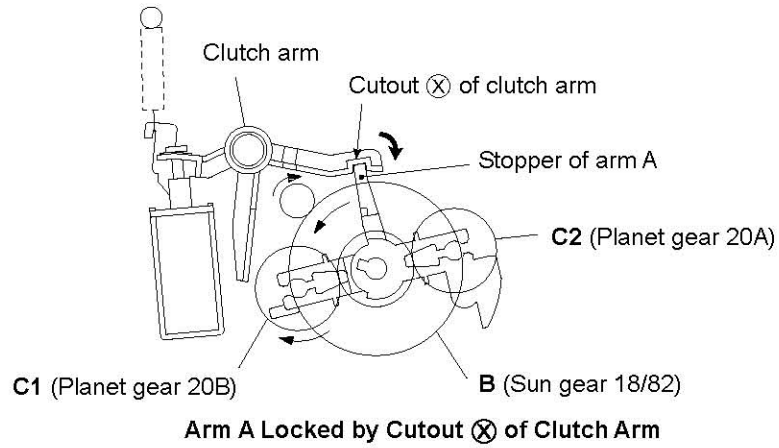

[2] Scanning mode (Solenoid: OFF, Motor rotation: Reverse)

Just as in the recording mode, the control electronics deactivates the solenoid in the scanning mode to lock arm A.

The motor rotates in the reverse direction and the sun gear 18/82 (B) rotates clockwise so that the planet gear 20B (C1) transmits the rotation to the separation roller gear (L) and white pressure roller gear (O) via the several gears.

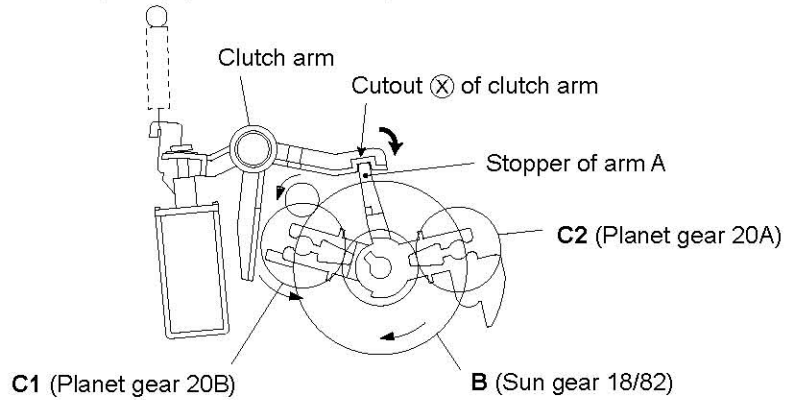

Arm A Locked by Cutout ⊗ of Clutch Arm

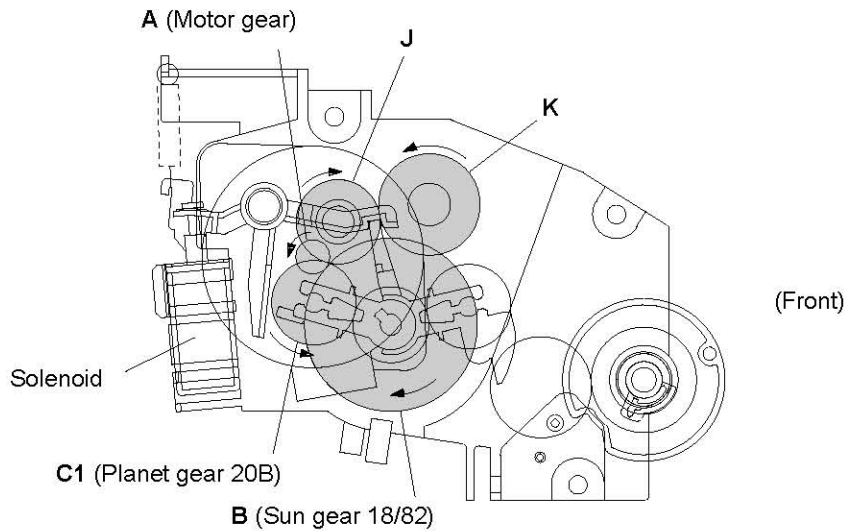

Active Gears on the Drive Unit

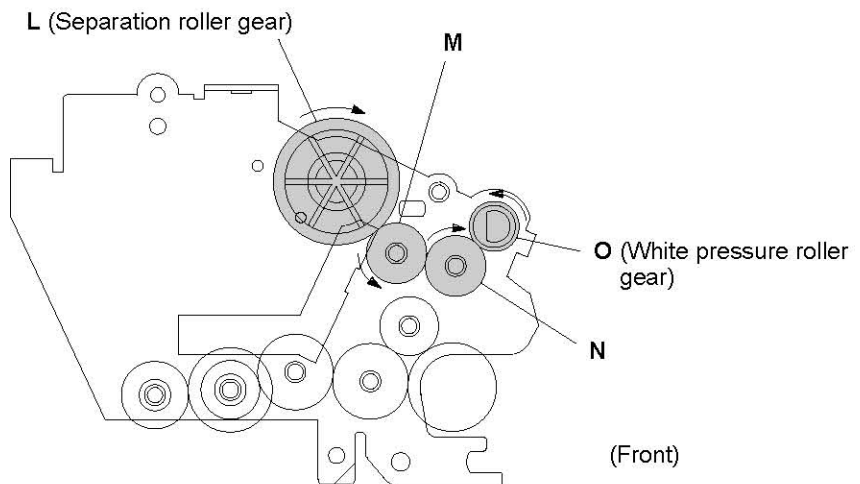

Active Gears on the Scanner Frame ASSY

[3] Copying mode (Solenoid: ON→OFF, Motor rotation: Forward)

The control electronics at first activates the solenoid to release the stopper of arm A from the cutout (⊗) of the clutch arm while rotating the motor in the forward direction. Accordingly, the sun gear 18/82 (B) rotates counterclockwise so that both the planet gears 20B (C1) and 20A (C2) transmit the rotation; C1 rotation to the platen gear (H) and C2 rotation to the separation roller gear (L) and white pressure roller gear (O).

Once the planet gear 20A (C2) becomes engaged with gear K, the control electronics deactivates the solenoid.

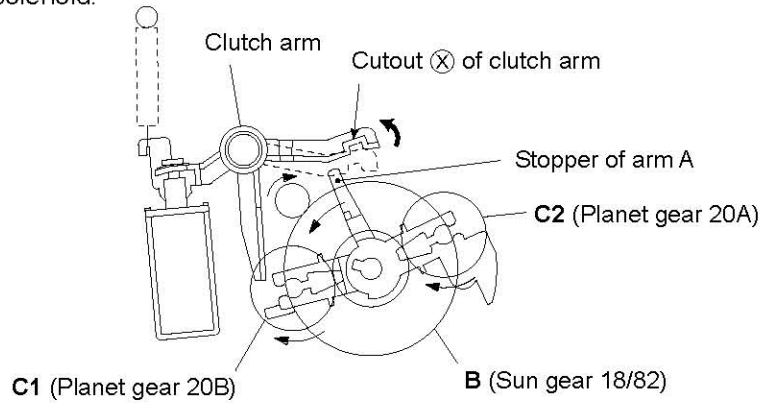

Arm A Released from Cutout (⊗) of Clutch Arm

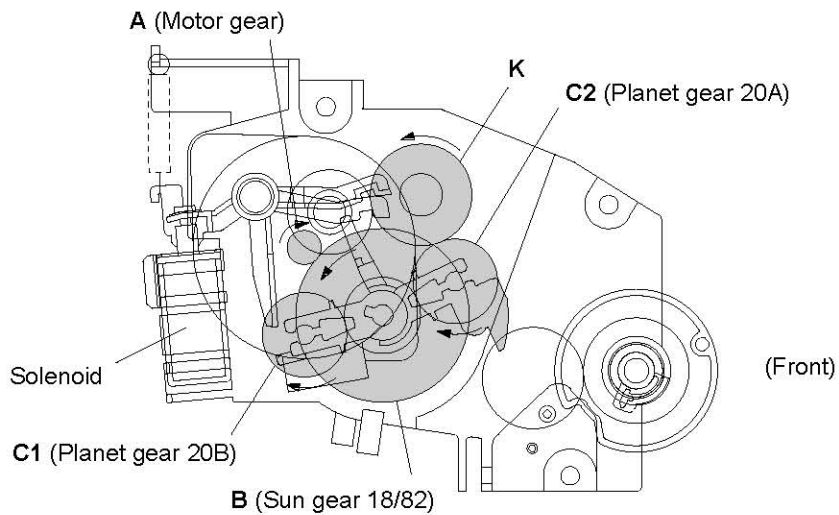

Active Gears on the Drive Unit

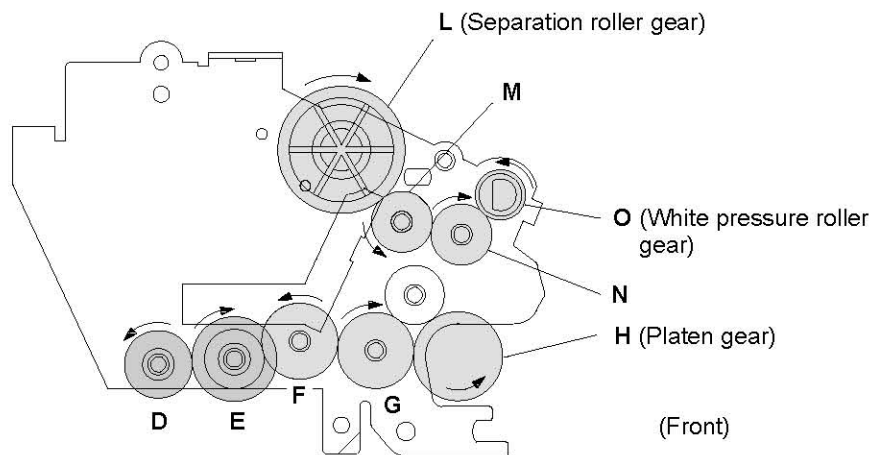

Active Gears on the Scanner Frame ASSY

[4] Cutter driving mode (Solenoid: ON, Motor rotation: Reverse)

The control electronics activates the solenoid to release the stopper of arm A from the clutch arm. When the motor rotates in the reverse direction, the sun gear 18/82 (B) rotates clockwise so that the planet gear 20A (C2) transmits the rotation to the cutter gear (Q) via gear P.

Since the planet gear 20B (C1) is blocked by the section Ⓢ of the clutch arm, it is merely idle without engaging with any other gear.

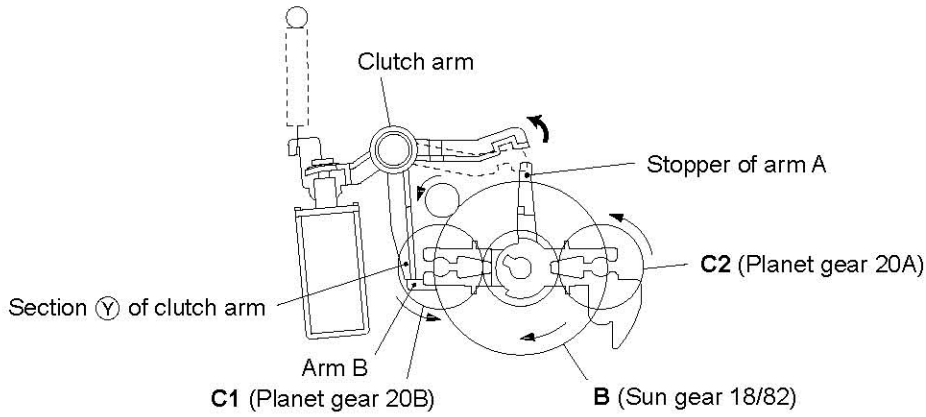

Arm B Blocked by Section Ⓢ of Clutch Arm

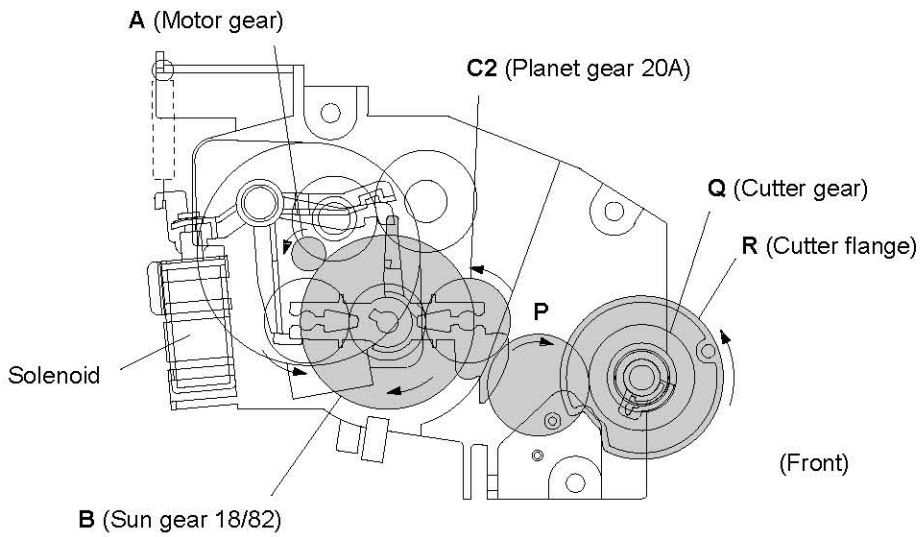

Active Gears on the Drive Unit

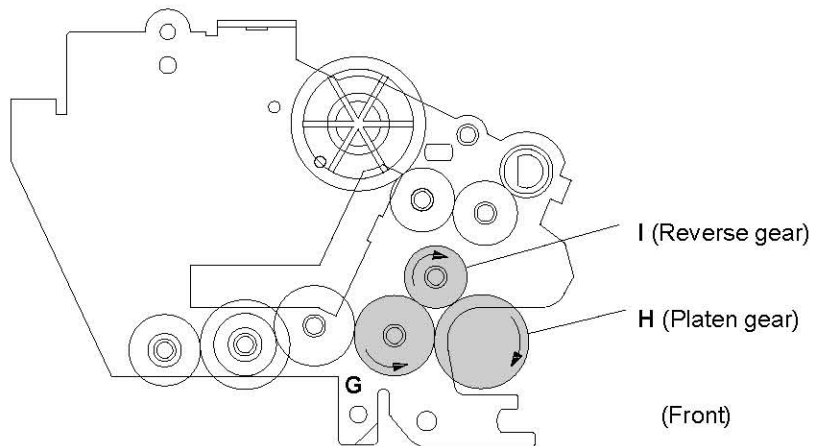

Active Gears on the Scanner Frame ASSY

The cutter gear (Q) is a two-stepped gear whose inside gear is a one-tooth sector gear. While the cutter gear (Q) rotates by one turn for one stroke of the upper blade of the cutter, the one-tooth sector gear slightly turns the platen gear (H) clockwise via the reverse gear (I) to feed the recording paper back into the equipment. This prevents the upper blade of the cutter from scratching the leading edge of the remaining paper.

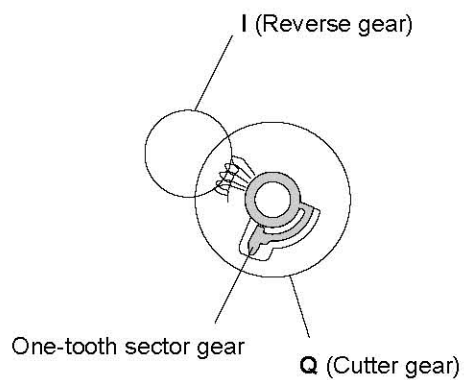

2.3.4 Power transmission route

Rotation of the motor gear is transmitted as shown below.

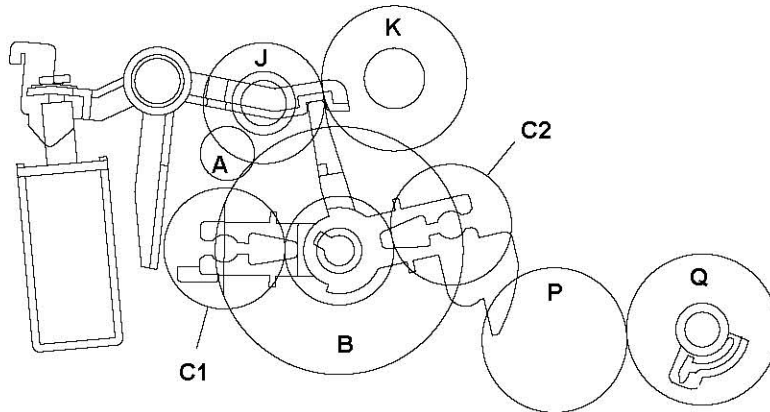

Gears on the Drive Unit

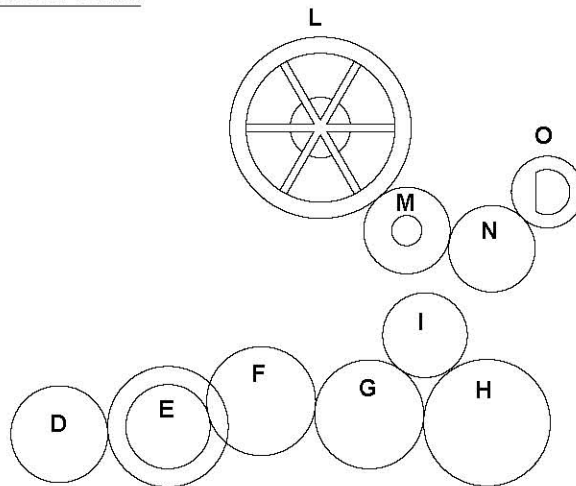

Gears on the Scanner Frame ASSY

- A: Motor gear
- B: Sun gear 18/82
- C1: Planet gear 20B
- C2: Planet gear 20A
- D: Gear 16
- E: Gear 14/20
- F: Gear 18
- G: Gear 18L
- H: Platen gear
- I: Reverse gear
- J: Gear 20
- K: Gear 16/24
- L: Separation roller gear
- M: Gear 23
- N: Flanged gear 23
- O: White pressure roller gear
- P: Gear 24
- Q: Cutter gear

[1] Recording Mode (Solenoid: OFF, Motor rotation: forward)

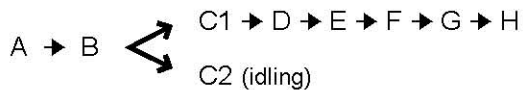

[2] Scanning Mode (Solenoid: OFF, Motor rotation: reverse)

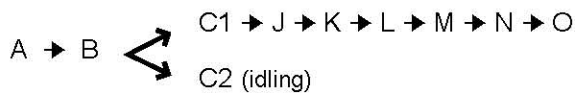

[3] Copying Mode (Solenoid: ON → OFF, Motor rotation: forward)

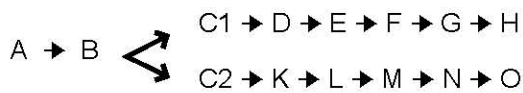

[4] Cutter Driving Mode (Solenoid: ON, Motor rotation: reverse)

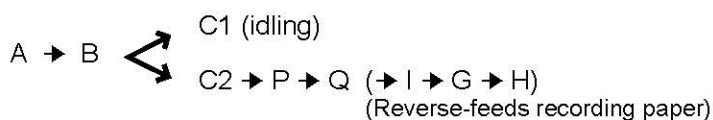

2.4 Sensors and Actuators

This equipment has two photosensors and four mechanical switches as described below.

Sensor name	Type	Located on
Document front sensor	Photosensor (PH1)	Main PCB
Document rear sensor	Photosensor (PH2)	Main PCB
Paper empty (PE) sensor	Mechanical switch (SW1)	Main PCB
Cover sensor	Mechanical switch (SW2)	Main PCB
Hook switch sensor	Mechanical switch (SW3)	Main PCB
Cutter home position (HP) sensor	Mechanical switch	Drive unit

- Document front sensor which detects the presence of documents.
- Document rear sensor which detects the leading and trailing edges of pages to tell the control circuitry when the leading edge of a new page has reached the starting position and when the scan for that page is over.

These photosensors are of a reflection type consisting of a light-emitting diode and a light-sensitive transistor. Each of them has an actuator separately arranged (see the next page). When an actuator is not activated, its white end lies in the path of light issued from the light-emitting diode and reflects its light into the light-sensitive transistor. If a document is fed in so as to activate the actuator, the actuator's white end goes out of the light path. With no reflected light to go into the light-sensitive transistor, the sensor detects the presence of documents.

- PE sensor which detects when the recording paper runs out.
- Cover sensor which detects whether the control panel is closed.
- Hook switch sensor which detects whether the handset is placed on the handset mount.
- Cutter HP sensor which detects the home position of the upper rotary blade of the automatic cutter.

Each of these four sensors has an actuator separately arranged (see the next page). If an actuator is activated, its lower end releases or pushes down the lever provided on the corresponding sensor so that the sensor signals the detection.

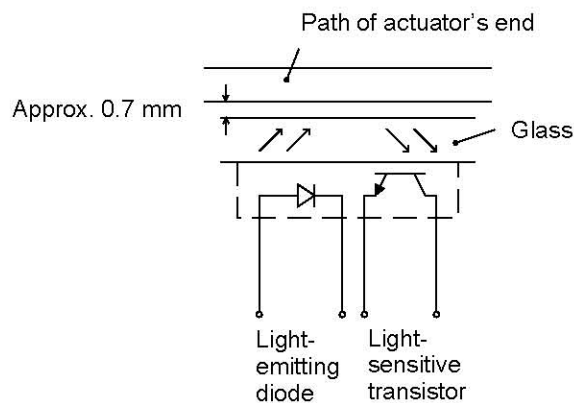

Photosensor

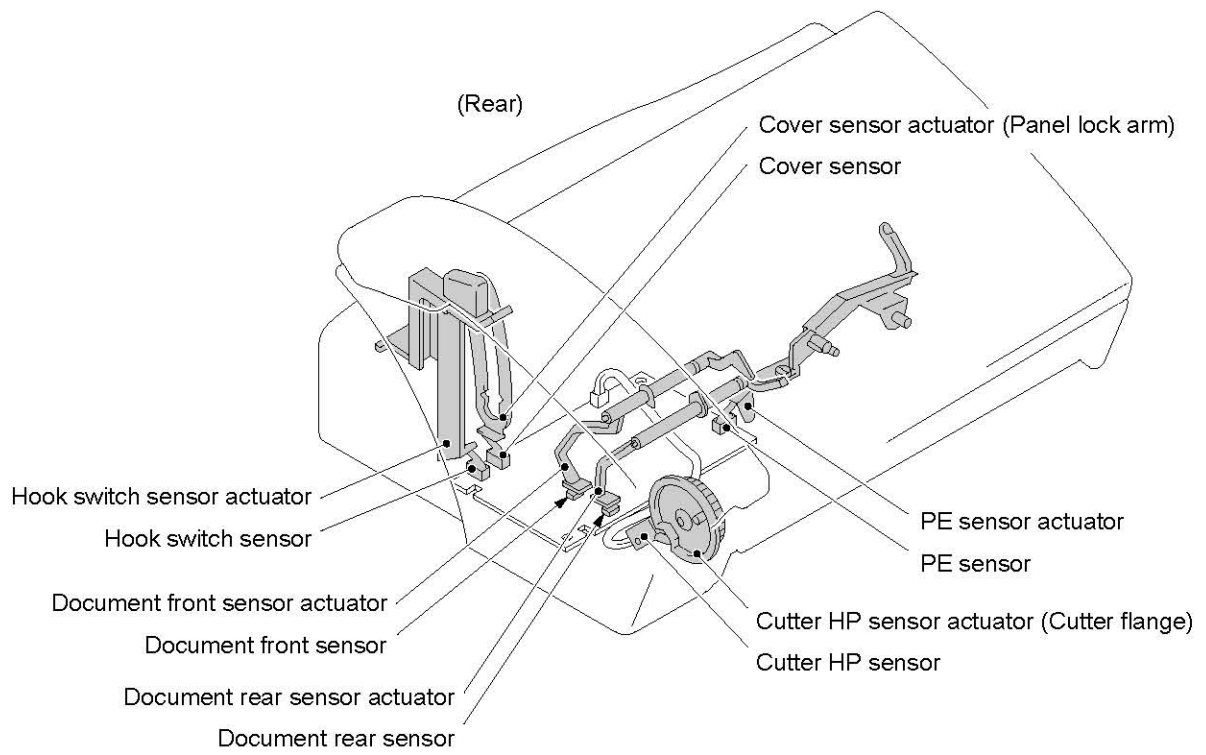

Location of Sensors and Actuators

3. CONTROL ELECTRONICS

3.1 Configuration

The hardware configuration of the facsimile equipment is shown below.

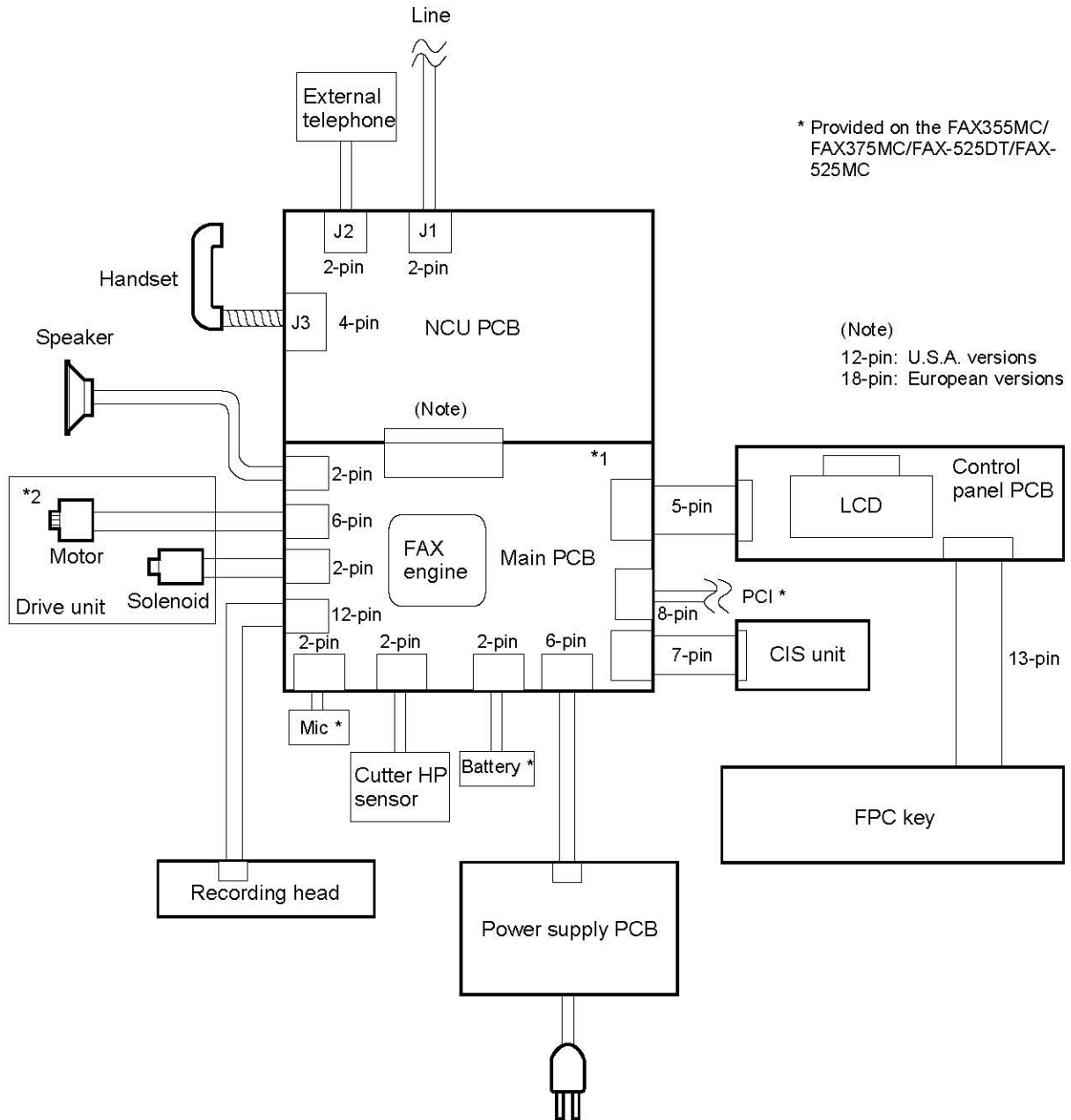

*1 On the main PCB are these sensors:

- PE sensor (SW1)
- Cover sensor (SW2)
- Hook switch sensor (SW3)
- Document front sensor (PH1)
- Document rear sensor (PH2)

*2 On the drive unit is the cutter HP sensor.

Configuration of Facsimile Equipment

3.2 Main PCB

The main PCB, which is the nucleus controlling the entire operation of the equipment, consists of a FAX engine (ASIC), memories, MODEM, motor drive circuitry, sensor detection circuitry, and analog circuits for scanning, recording, and power transmission shifting.

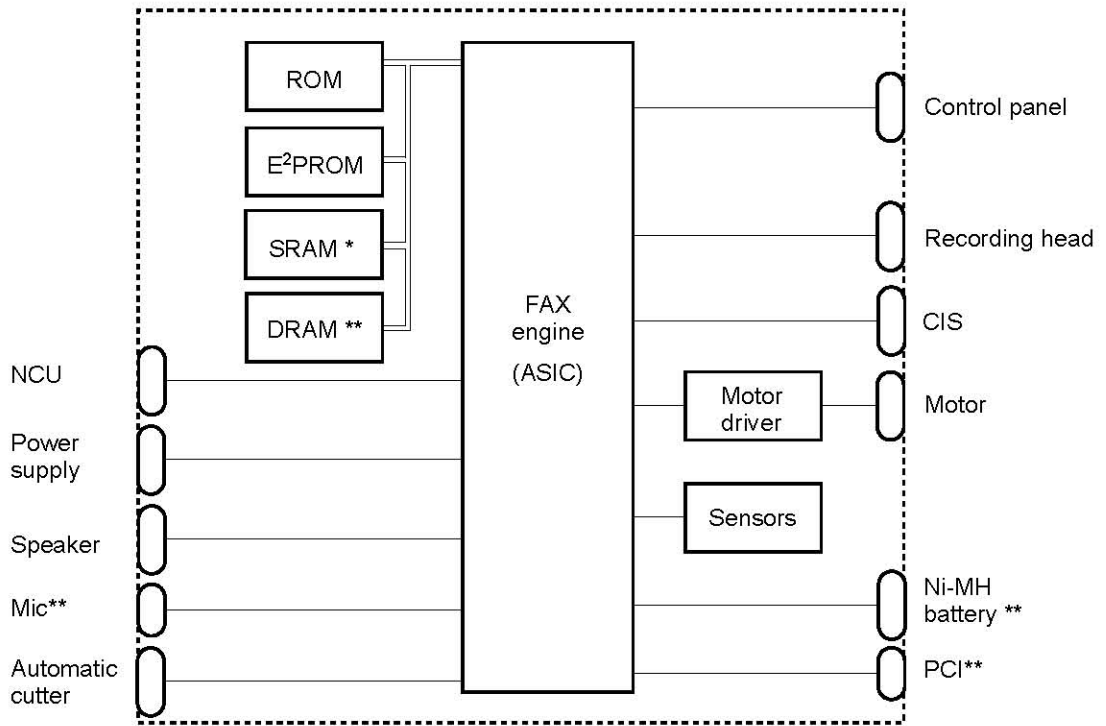

E²PROM: Electrically Erasable Programmable Read-only Memory

* Provided on the FAX255/FAX275/FAX-515/HOMEFAX3

** Provided on the FAX355MC/FAX375MC/FAX-525DT/FAX-525MC

Block Diagram of Main PCB

FAX255/FAX275/FAX-515/HOMEFAX3

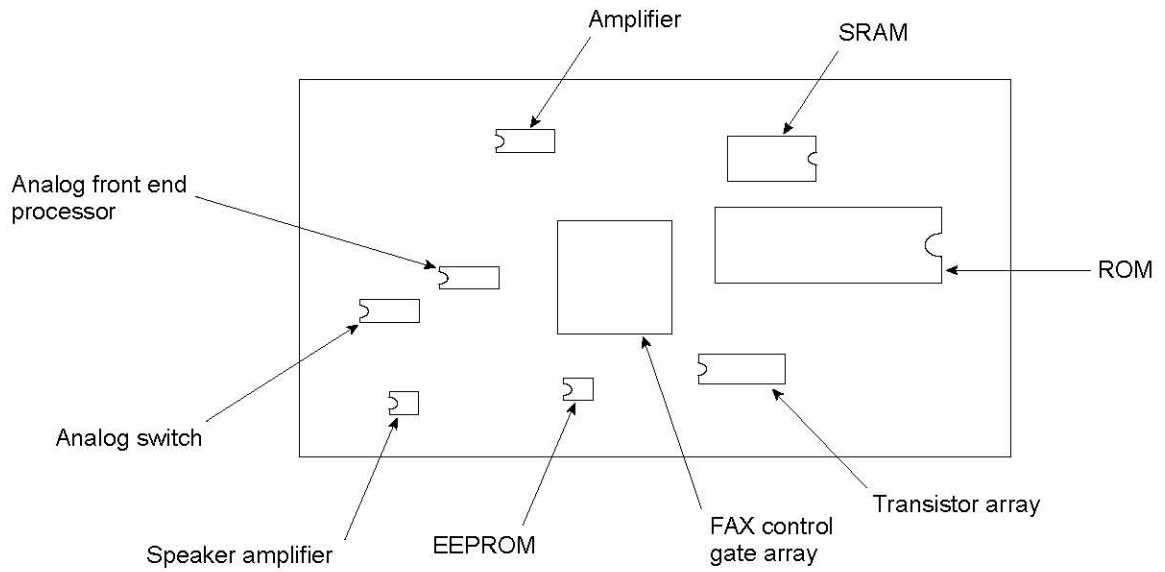

FAX355MC/FAX375MC/FAX-525DT/FAX-525MC

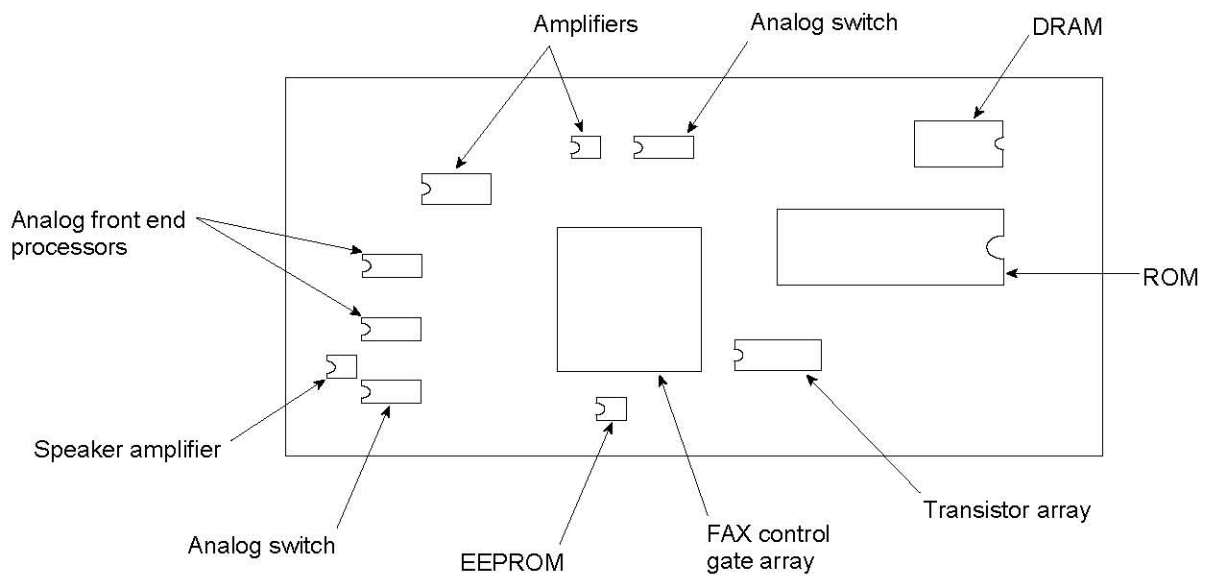

3.3 NCU PCB

The NCU PCB switches the communications line to telephone or built-in MODEM, under the control of the main PCB.

U.S.A. versions

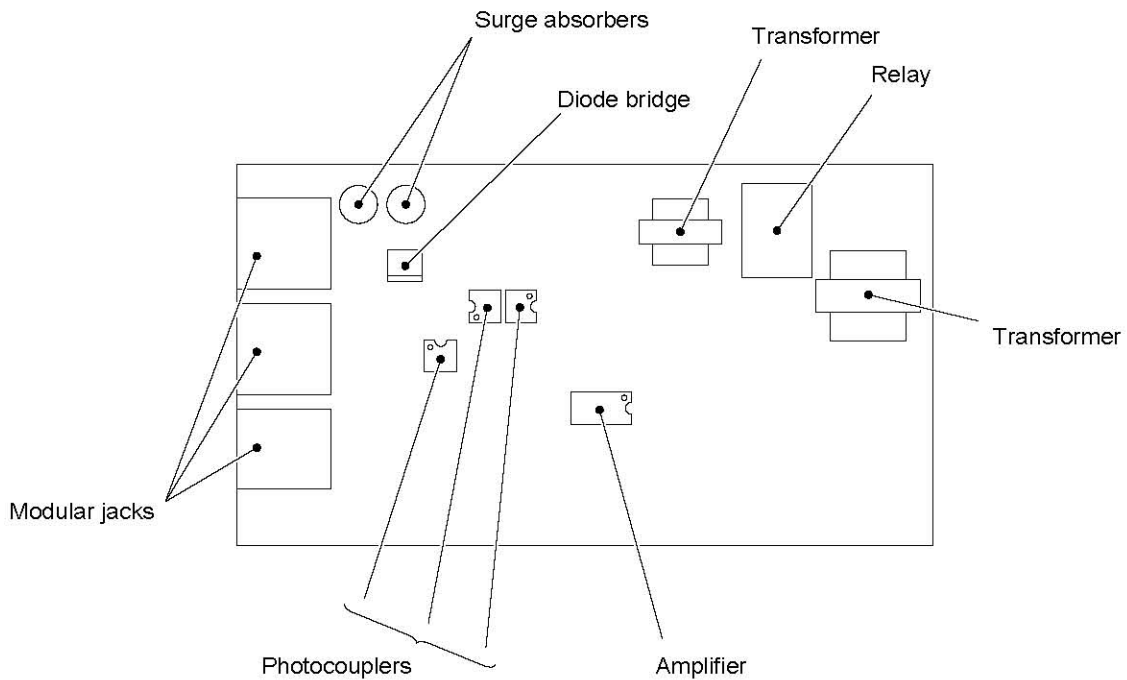
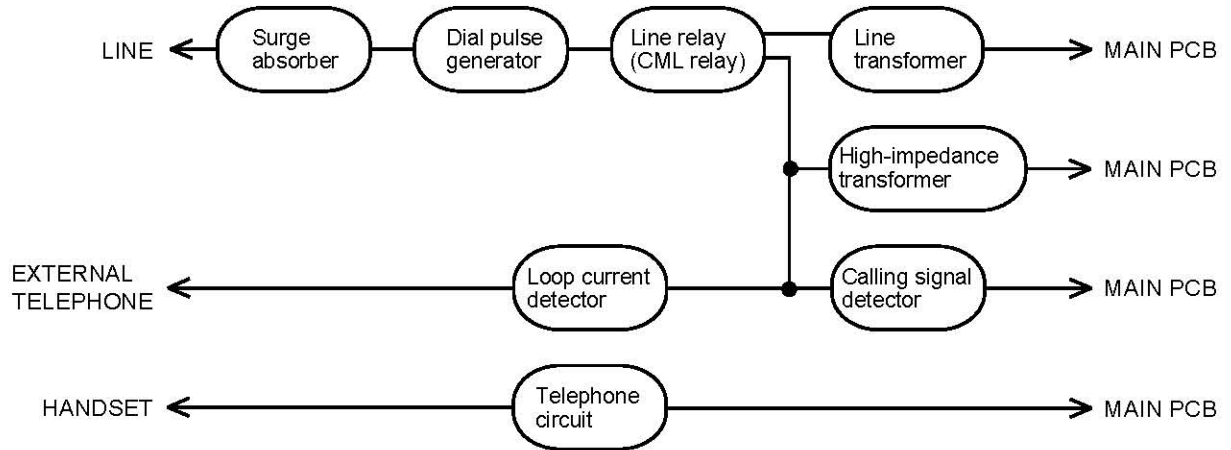

European versions

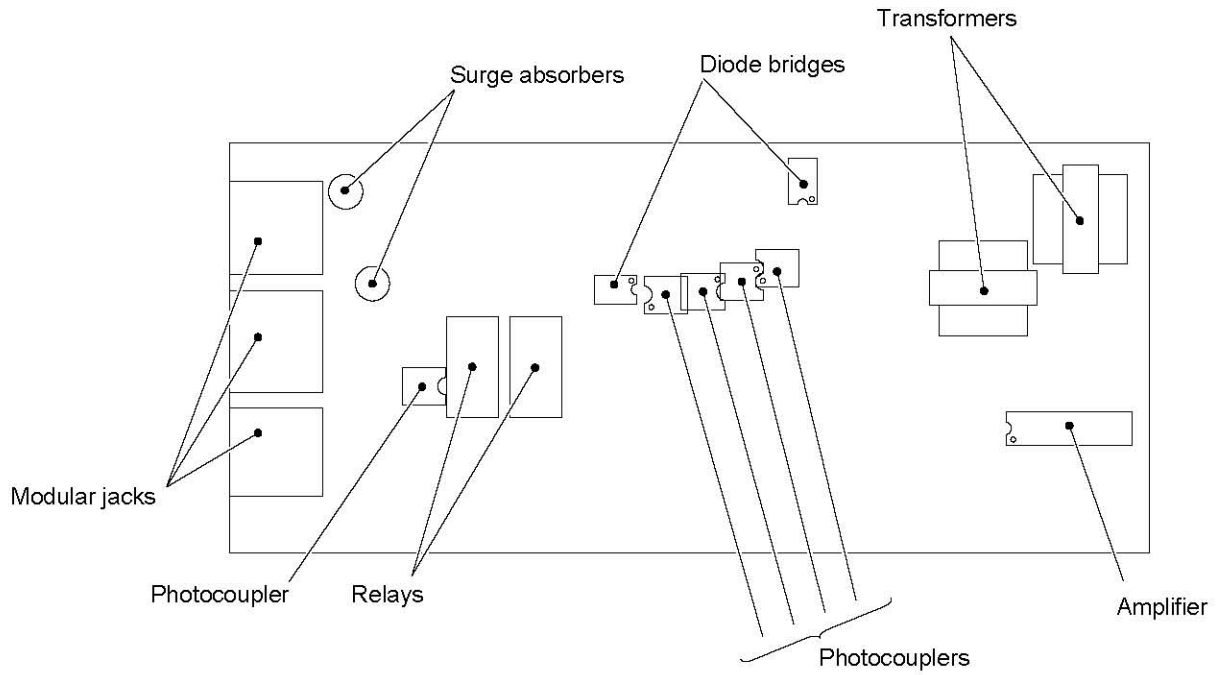
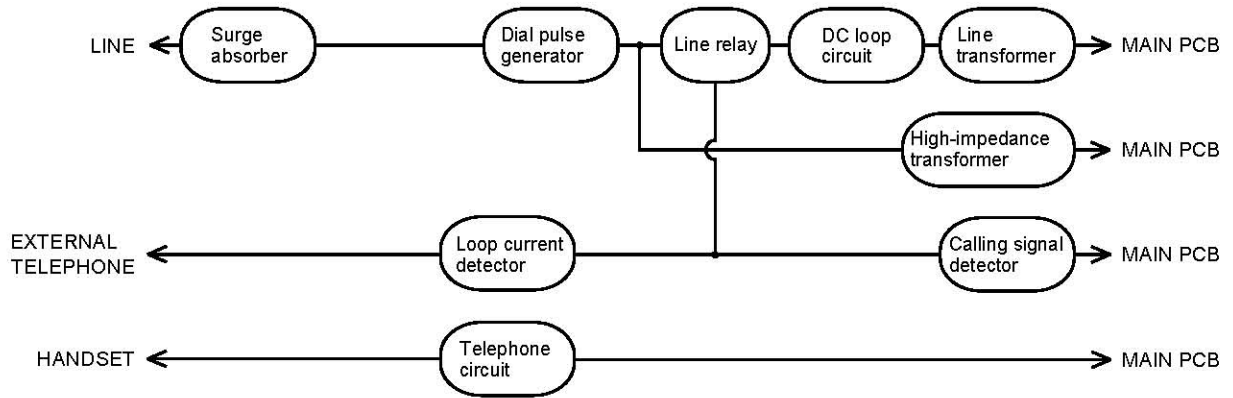

3.4 Control Panel PCB

The control panel PCB and the main PCB communicate with each other by serially transmitting commands and data.

The control panel unit consists of a gate array and LCD, which are controlled by the gate array according to commands issued from the FAX engine on the main PCB.

The calendar clock is backed up by the backup circuit on the main PCB.

The panel FPC is a flexible keyboard PCB which integrates the key matrix having rubber keytops.

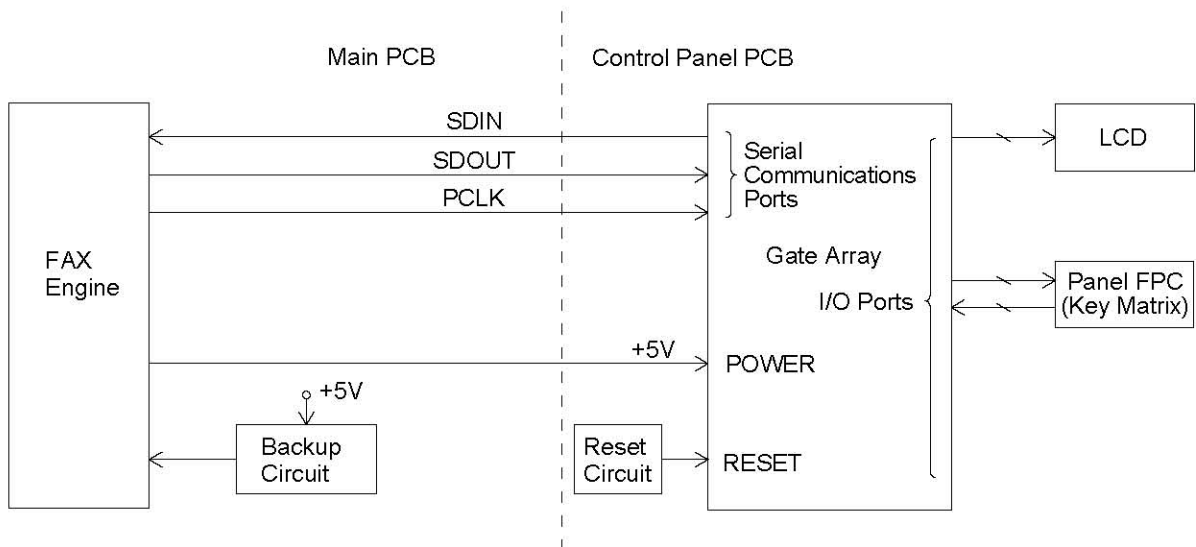

Control Panel PCB and its Related Circuit

3.5 Power Supply PCB

The power supply uses the switching regulation system to generate DC power (+26.6V and +8V) from a commercial AC power supply.

The +26.6V source is stabilized and fed to the motor and solenoid for feeding documents and recording paper or activating the automatic cutter, and also fed to the CIS LED array. It is also fed to the main PCB where the H26.6V source is generated. The H26.6V source outputs 26.6V only when the H26.6V ON/OFF control signal is High, for driving the recording head.

The +8V source is not stabilized and fed to the speaker. It is also fed to the main PCB where the 3-terminal regulator eliminates unstabilized components of the +8V source to generate stabilized +5V source. The +5V source is fed to the logic, control panel, and sensors.

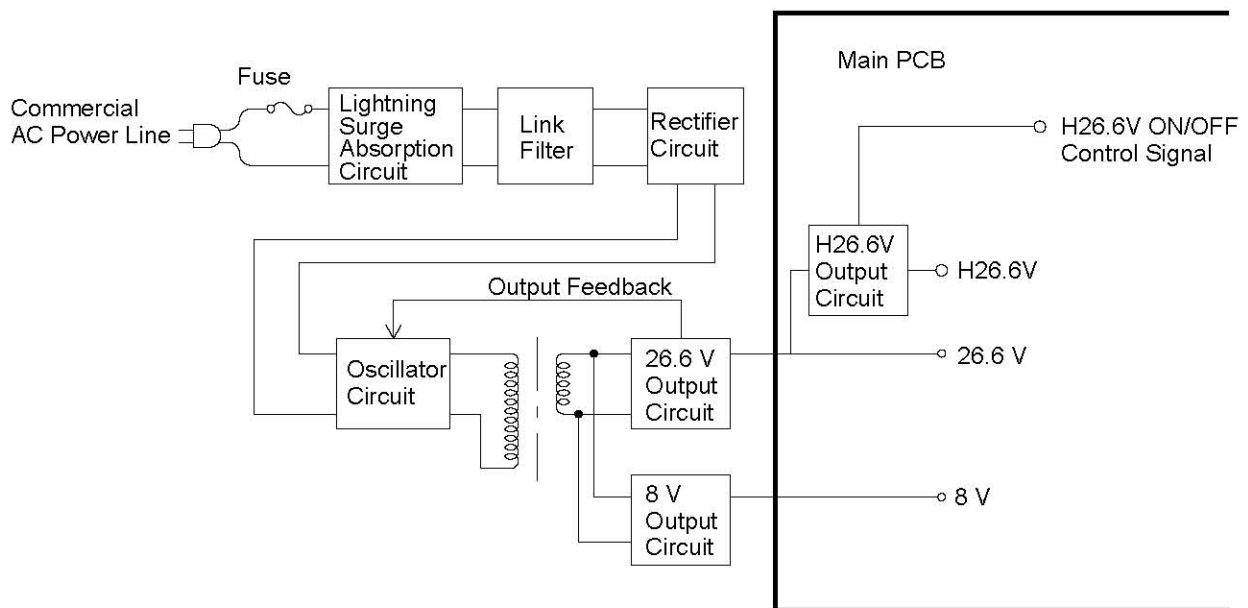

Power Supply Circuit

CHAPTER IV.
DISASSEMBLY/REASSEMBLY
AND LUBRICATION

CHAPTER IV. DISASSEMBLY/REASSEMBLY AND LUBRICATION

CONTENTS

1. DISASSEMBLY/REASSEMBLY	IV-1
■ Safety Precautions	IV-1
■ Preparation	IV-3
■ How to Access the Object Component	IV-3
■ Disassembly Order Flow	IV-4
1.1 ACS Plate	IV-5
1.2 ROM Cover and Battery ASSY	IV-6
1.3 Inner Cover	IV-8
1.4 Control Panel ASSY	IV-9
1.5 Recording Paper Cover, Panel Rear Cover, Control Panel and Microphone	IV-11
1.6 Scanner Frame ASSY	IV-14
1.7 White Pressure Roller and CIS Unit	IV-17
1.8 Drive Unit (Main Motor and Cutter HP Sensor)	IV-18
1.9 Separation Roller ASSY	IV-21
1.10 Document Front and Rear Sensor Actuators	IV-22
1.11 Recording Head Release Lever	IV-23
1.12 Recorder & Cutter ASSY	IV-24
1.13 Platen and Cutter Chute	IV-25
1.14 Recording Head and Cutter Unit	IV-26
1.15 Hook Switch Sensor Actuator	IV-27
1.16 Speaker	IV-27
1.17 Bottom Plate	IV-28
1.18 Main PCB, NCU PCB and Power Supply PCB	IV-29
1.19 Paper Empty Sensor Actuator	IV-33
2. LUBRICATION	IV-34

1. DISASSEMBLY/REASSEMBLY

■ Safety Precautions

To prevent the creation of secondary problems by mishandling, observe the following precautions during maintenance work.

- (1) Always turn off the power before replacing parts or units. When having access to the power supply, be sure to unplug the power cord from the power outlet.
- (2) Be careful not to lose screws, washers, or other parts removed for parts replacement.
- (3) When using soldering irons and other heat-generating tools, take care not to damage the resin parts such as wires, PCBs, and covers.
- (4) Before handling the PCBs, touch a metal portion of the equipment to discharge static electricity; otherwise, the electronic parts may be damaged due to the electricity charged in your body.
- (5) When transporting PCBs, be sure to wrap them in conductive sheets such as aluminum foil.
- (6) Be sure to reinsert self-tapping screws correctly, if removed.
- (7) Tighten screws to the torque values listed on the next page.
- (8) When connecting or disconnecting cable connectors, hold the connector bodies not the cables. If the connector has a lock, always slide the connector lock to unlock it.
- (9) Before reassembly, apply the specified lubricant to the specified points. (Refer to Section 2 in this chapter.)
- (10) After repairs, check not only the repaired portion but also that the connectors and other related portions function properly before operation checks.

Tightening Torque List

Location	Screw type	Q'ty	Tightening torque kgf•cm (N•cm)
Recording paper cover	Taptite, cup B M3x8	2	5 ±2 (49 ±20)
Panel rear cover	Taptite, cup B M3x8	4	5 ±2 (49 ±20)
Control panel PCB	Taptite, cup B M3x8	1*	5 ±2 (49 ±20)
Scanner frame ASSY	Taptite, cup B M3x8	2	5 ±2 (49 ±20)
Drive unit	Taptite, cup S M3x6	3	7 ±2 (69 ±20)
	Taptite, cup S M3x8	1	7 ±2 (69 ±20)
Motor	Taptite, cup S M3x6	1	6 ±2 (59 ±20)
Cutter HP sensor	Taptite, pan B M1.6x8	1	1 ±0.5 (10 ±5)
Recorder & cutter unit	Taptite, cup S M3x8	1	7 ±2 (69 ±20)
Bottom plate	Taptite, cup B M3x8	4	5 ±2 (49 ±20)
Grounding wire	Screw, pan (washer) 4x6DB	1	7 ±2 (69 ±20)

* Provided on the FAX355MC/FAX375MC/FAX-525DT/FAX525MC

■ Preparation

Prior to proceeding to the disassembly procedure,

- (1) Unplug
 - the modular jack of the telephone line,
 - the modular jack of the curled cord (and remove the handset), and
 - the modular jack of an external telephone set if mounted. (Not shown below.)
- (2) Remove
 - the document support.

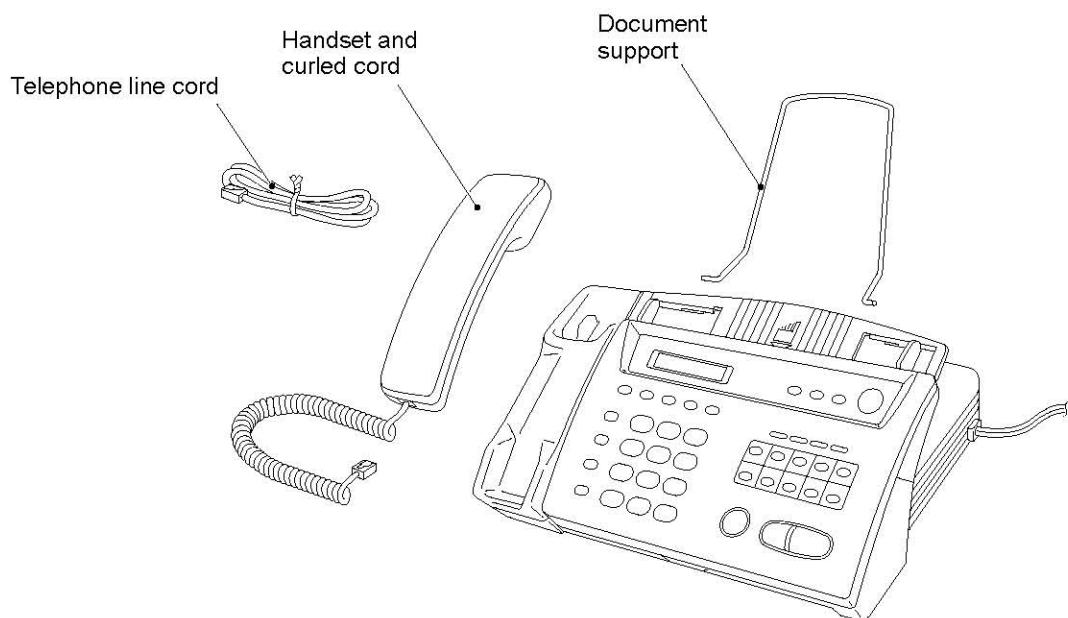

■ How to Access the Object Component

- On the next page is a disassembly order flow which helps you access the object component. To remove the recording head, for example, first find it on the flow and learn its number (⑭ in this case). You should remove parts numbered ① through ④, ⑥, ⑧, ⑪, ⑫, and ⑬ so as to access the recording head.
- Unless otherwise specified, the disassembled parts or components should be reassembled in the reverse order of removal.

■ **Disassembly Order Flow**

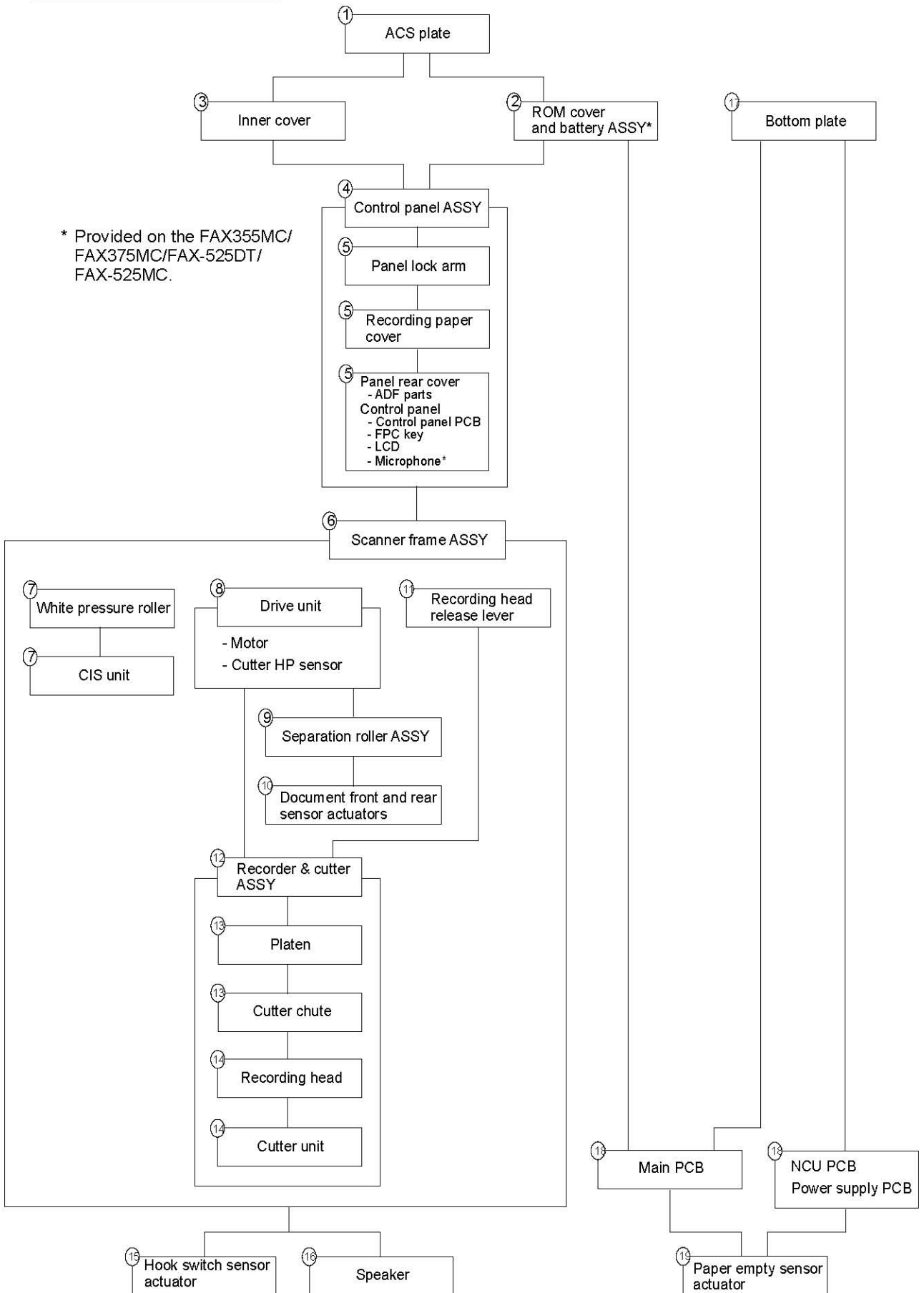

1.1 ACS Plate

- (1) Open the control panel ASSY.
- (2) Push down the locking pawl of the main frame with the tip of a flat screwdriver and move the ACS plate to the left.

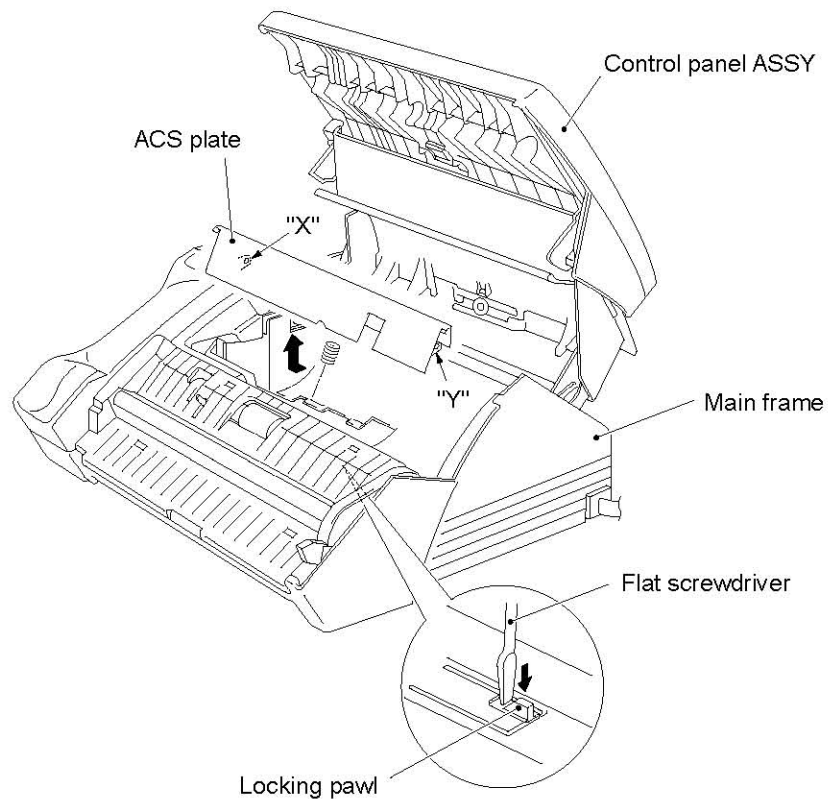

■ Reassembling Notes

- When installing the ACS plate, first fit hole "X" at the left end of the ACS plate over the left-hand boss provided on the main frame and then fit hole "Y" at the right end over the right-hand boss.

1.2 ROM Cover and Battery ASSY*

(*FAX355MC/FAX375MC/FAX-525DT/FAX-525MC)

- (1) Insert the tip of the spring hook at the center or left half of the locking arm as shown below, then lift up the hook to release and move the ROM cover to the right.
- (2) For the FAX355MC/FAX375MC/FAX-525DT/FAX-525MC: Slightly lift up the ROM cover and disconnect the battery harness from the main PCB, then take out the ROM cover together with the battery ASSY.
- (3) For the FAX355MC/FAX375MC/FAX-525DT/FAX-525MC: Remove the battery ASSY from the ROM cover.

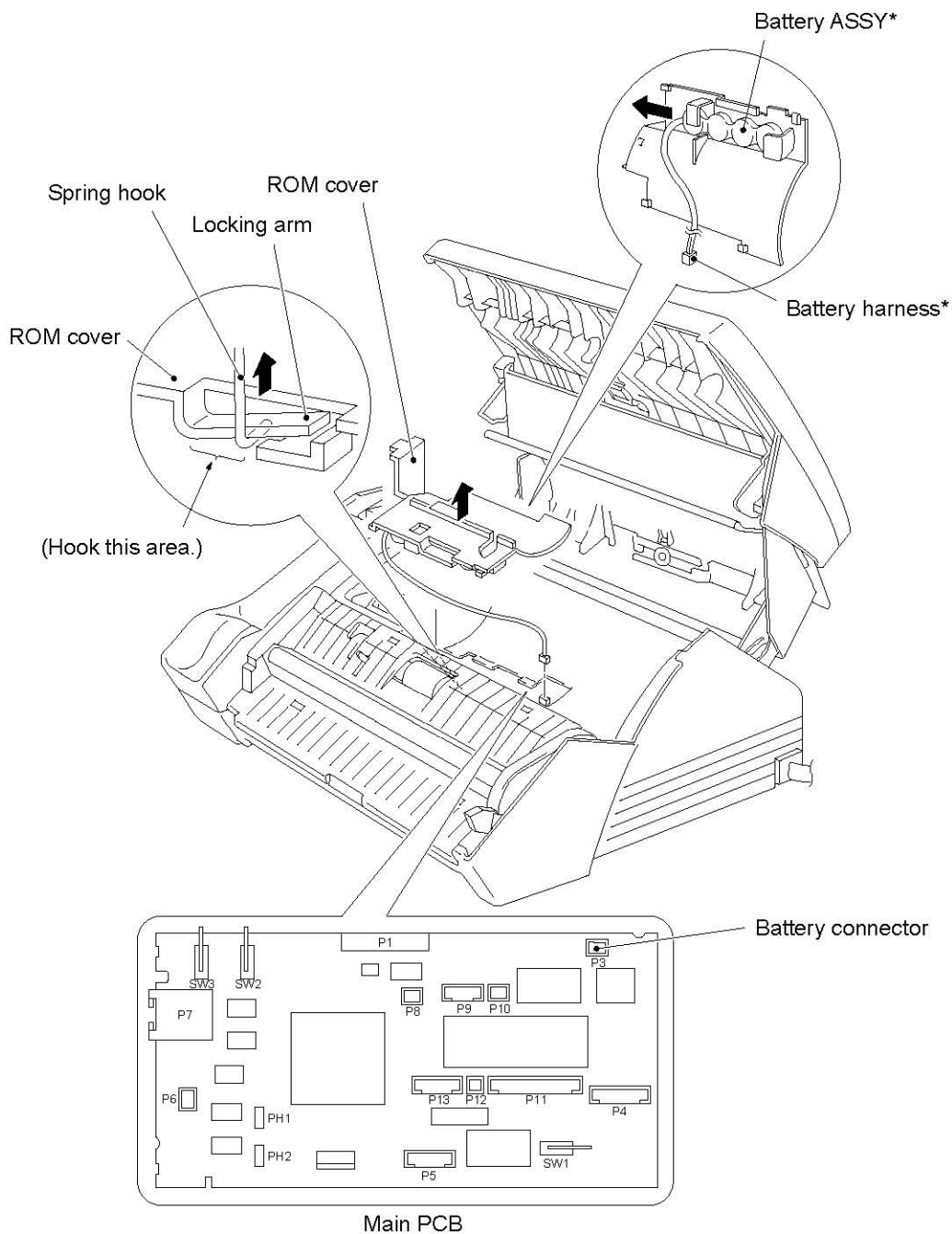

(FAX355MC/FAX375MC/FAX-525DT/FAX-525MC)

- (4) For the FAX355MC/FAX375MC/FAX-525DT/FAX-525MC: To take out the main PCB or the power supply PCB in Section 1.18, unhook the battery harness core and cutter HP sensor harness core from bosses "C" and "D," respectively, at this stage.

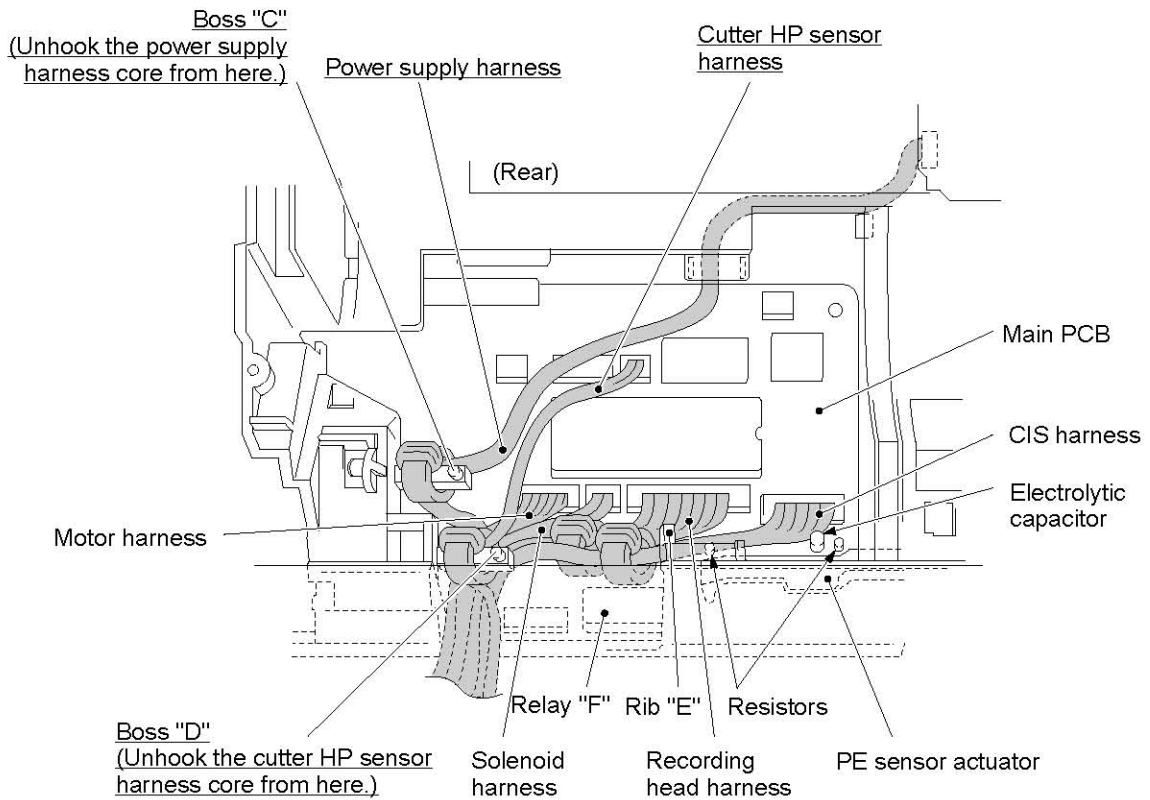

1.3 Inner Cover

- (1) Swing the recording head release lever (blue lever) up to the head release position.
- (2) While lifting up the inner cover slightly, release the four latches with the tip of a flat screwdriver in the order (① to ④) shown below.

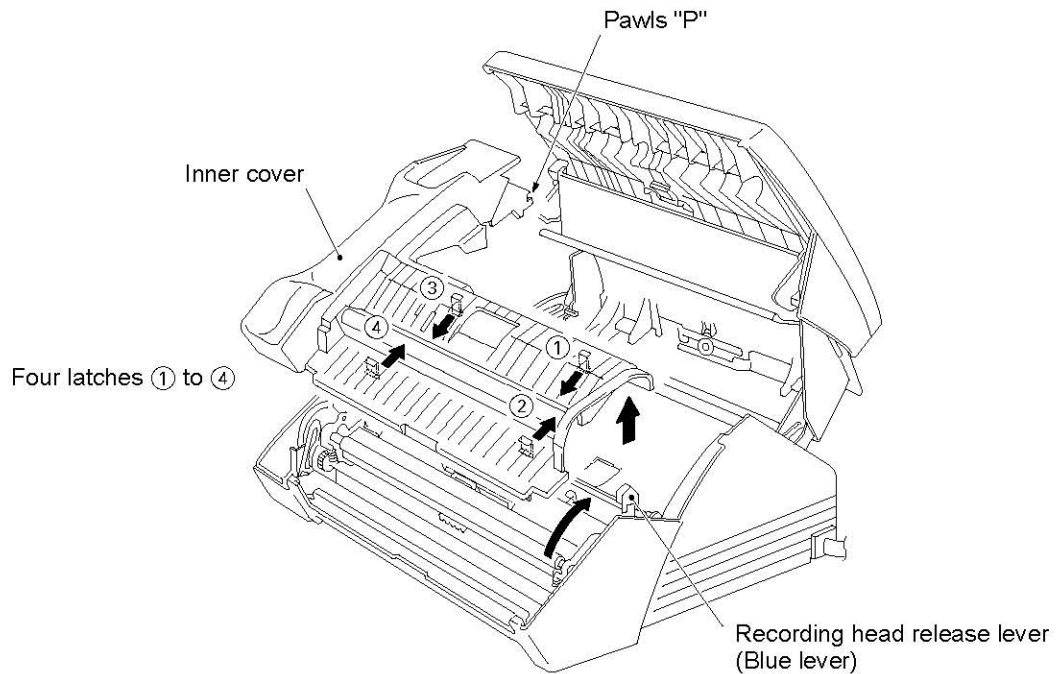

■ Reassembling Notes

- Before installing the inner cover, swing the recording head release lever up for greater ease.
- Fit the pawls "P" of the inner cover into the square hole provided in the left rear corner of the main frame and then push the inner cover down into place.

1.4 Control Panel ASSY

- (1) Disconnect the main-panel harness and the main-mic harness* from the main PCB, and then take out those harnesses from the groove of the main frame.
- (2) Slightly bring the control panel ASSY back up towards you so that you can release the panel lock arm from the boss of the main frame. Pull out the panel lock arm to the left and fully open the control panel ASSY.

* The main-mic harness is provided on the FAX355MC/FAX375MC/FAX-525DT/FAX-525MC.

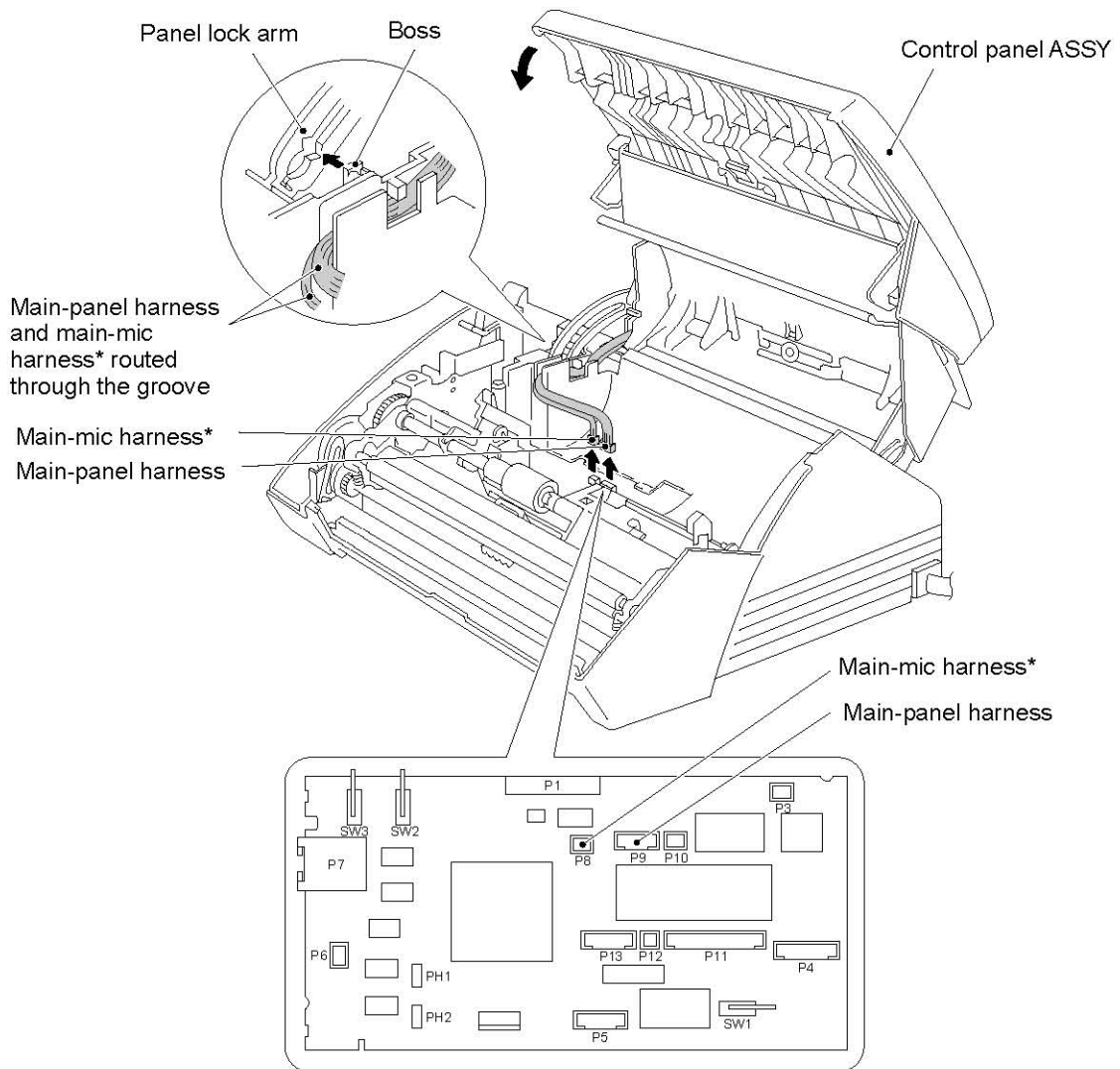

(Main PCB)

(FAX355MC/FAX375MC/FAX-525DT/FAX-525MC)

- (3) Push the control panel ASSY back and remove it.

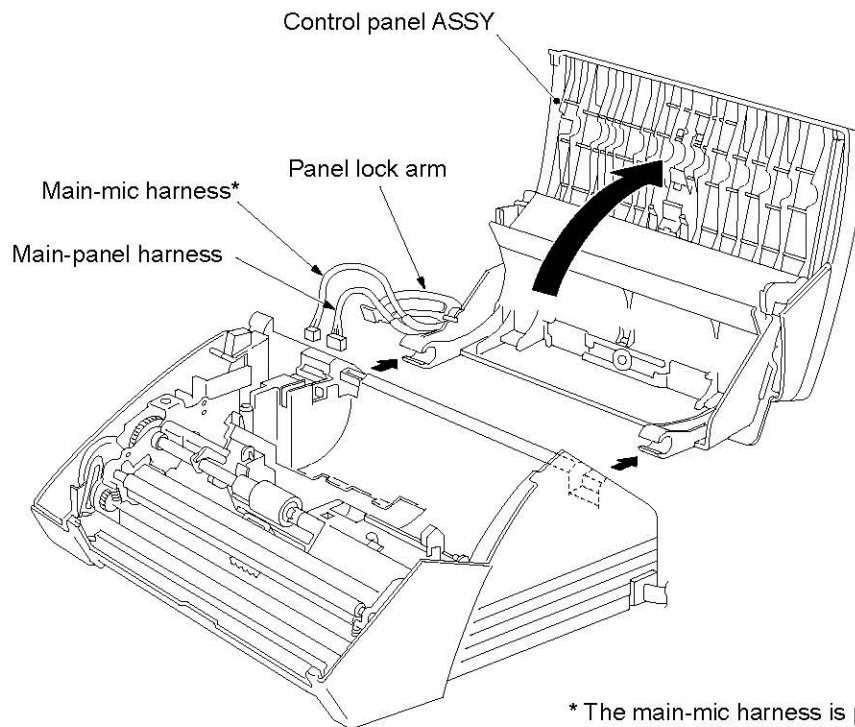

* The main-mic harness is provided on the FAX355MC/FAX375MC/FAX-525DT/FAX-525MC.

■ Reassembling Notes

- Make sure that the main-panel harness and main-mic harness* are routed through the groove provided on the recording paper cover and are kept in place with the panel lock arm, as illustrated on page IV-13.

1.5 Recording Paper Cover, Panel Rear Cover, Control Panel and Microphone*

(*FAX355MC/FAX375MC/FAX-525DT/FAX-525MC)

- (1) Place the control panel ASSY upside down.
- (2) Turn the panel lock arm until the cutout provided in it becomes aligned with the boss of the arm support, then pull it out to the left.
- (3) Remove the two screws "a" from the recording paper cover and lift up the rear edge of the cover.
- (4) Remove the ADF parts (ADF film, separator and leaf spring), using the spring hook and a flat screwdriver. Once removed, they will become unusable and new parts should have to be put back in.
- (5) Remove the four screws "b" from the panel rear cover, then unhook the latches "L" and lift up the cover.
- (6) For the FAX355MC/FAX375MC/FAX-525DT/FAX-525MC: Remove the screw "c" from the control panel PCB.

Unlock the LCD cable connector and disconnect the LCD flat cable to take out the control panel PCB and the FPC key.

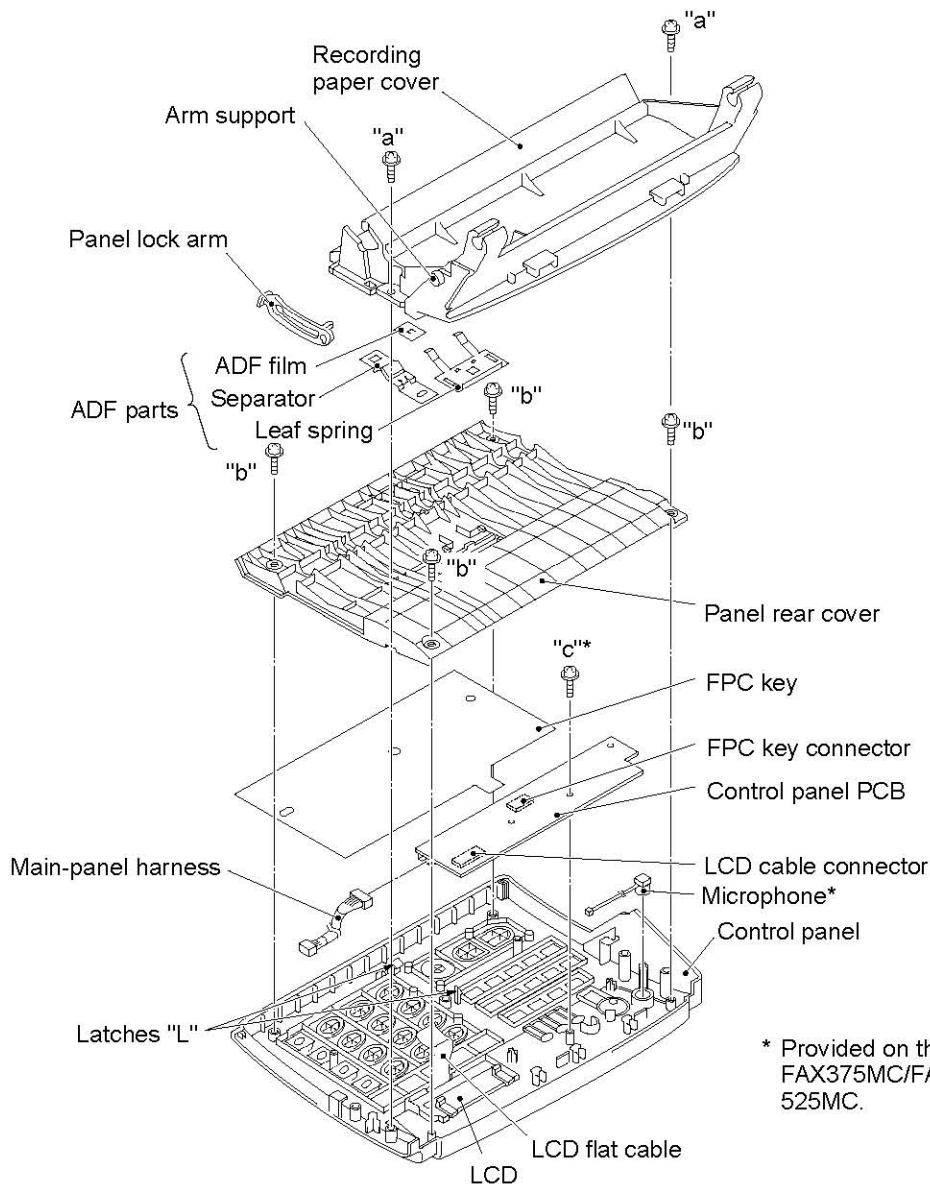

* Provided on the FAX355MC/
FAX375MC/FAX-525DT/FAX-
525MC.

- (7) To separate the FPC key from the control panel PCB, unlock the FPC key connector and disconnect the FPC key.
- (8) For the FAX355MC/FAX375MC/FAX-525DT/FAX-525MC: Take out the microphone* and its harness* from the control panel.

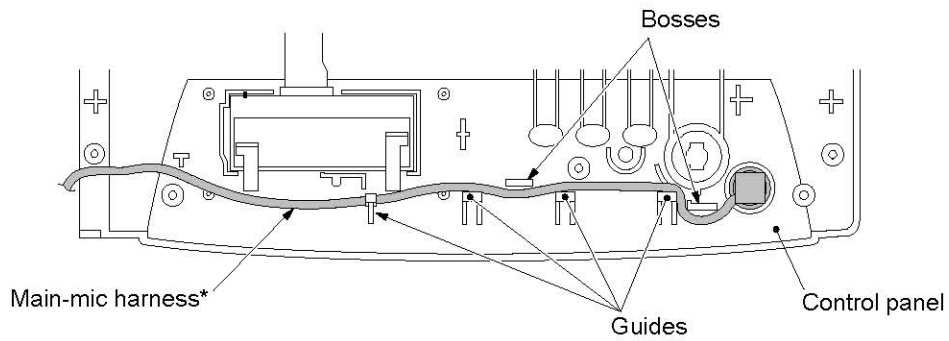

* Provided on the FAX355MC/FAX375MC/
FAX-525DT/FAX-525MC.

- (9) To take out the LCD, remove the control panel PCB and the FPC key in step (6). Pull up the clamps with your fingers and take out the LCD to the front, as shown below.

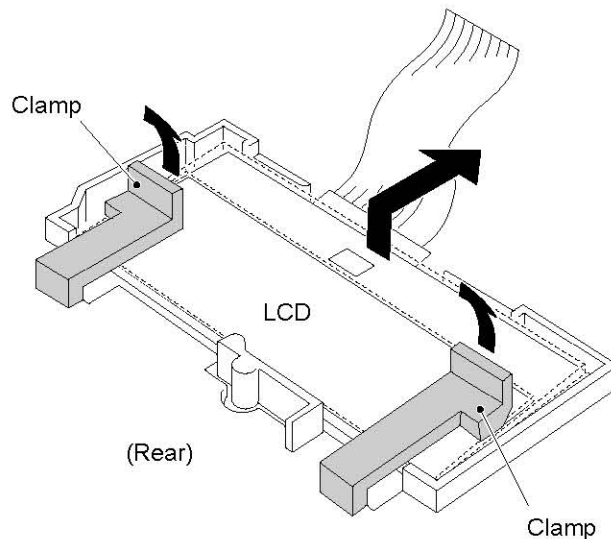

■ Reassembling Notes

- When installing the LCD, take care not to scratch or damage the cover sheet. Replace it if scratched or damaged.
- A new LCD is covered with a protection sheet. Before installing it, remove the protection sheet.

- When setting the recording paper cover on the control panel, first insert the right and left front corners under sections "X" of the control panel and put the cover into place. Make sure that the main-panel harness and main-mic harness* are routed as shown below.

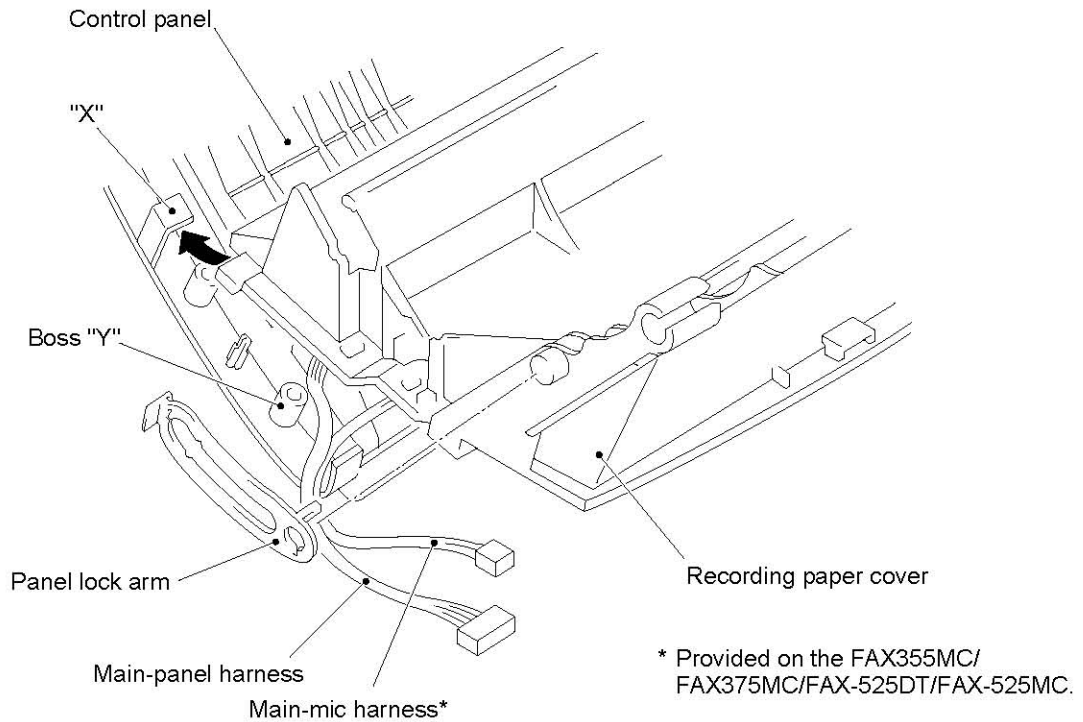

- After securing the recording paper cover with the screws, be sure to route the main-panel harness and the main-mic harness* through the groove provided on the recording paper cover and then set the panel lock arm to keep those harnesses in place, as illustrated below.

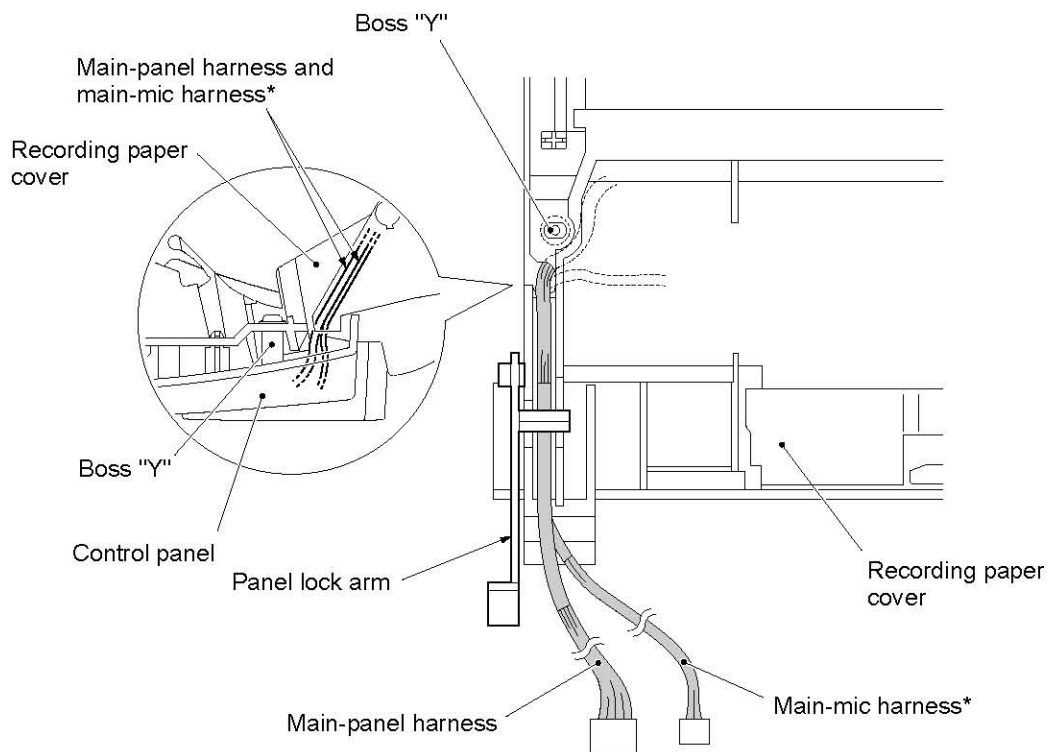

1.6 Scanner Frame ASSY

- (1) Be sure to swing the recording head release lever (blue lever) down to the front position.
 - (2) Remove the two screws.
 - (3) Slightly lift up the rear edge of the scanner frame ASSY and disconnect the following five harnesses from the main PCB:
 - Cutter home position (HP) sensor harness (2-pin)
 - CIS harness (7-pin)
 - Recording head harness (12-pin)
 - Solenoid harness (2-pin)
 - Motor harness (6-pin)
 - (4) Lift up the scanner frame ASSY from the rear and take it out from the main frame.
- NOTE: Do not hold the lower paper chute but the upper paper chute. The lower paper chute is easily deformed.

FAX255/FAX275/FAX-515/HOMEFAX3

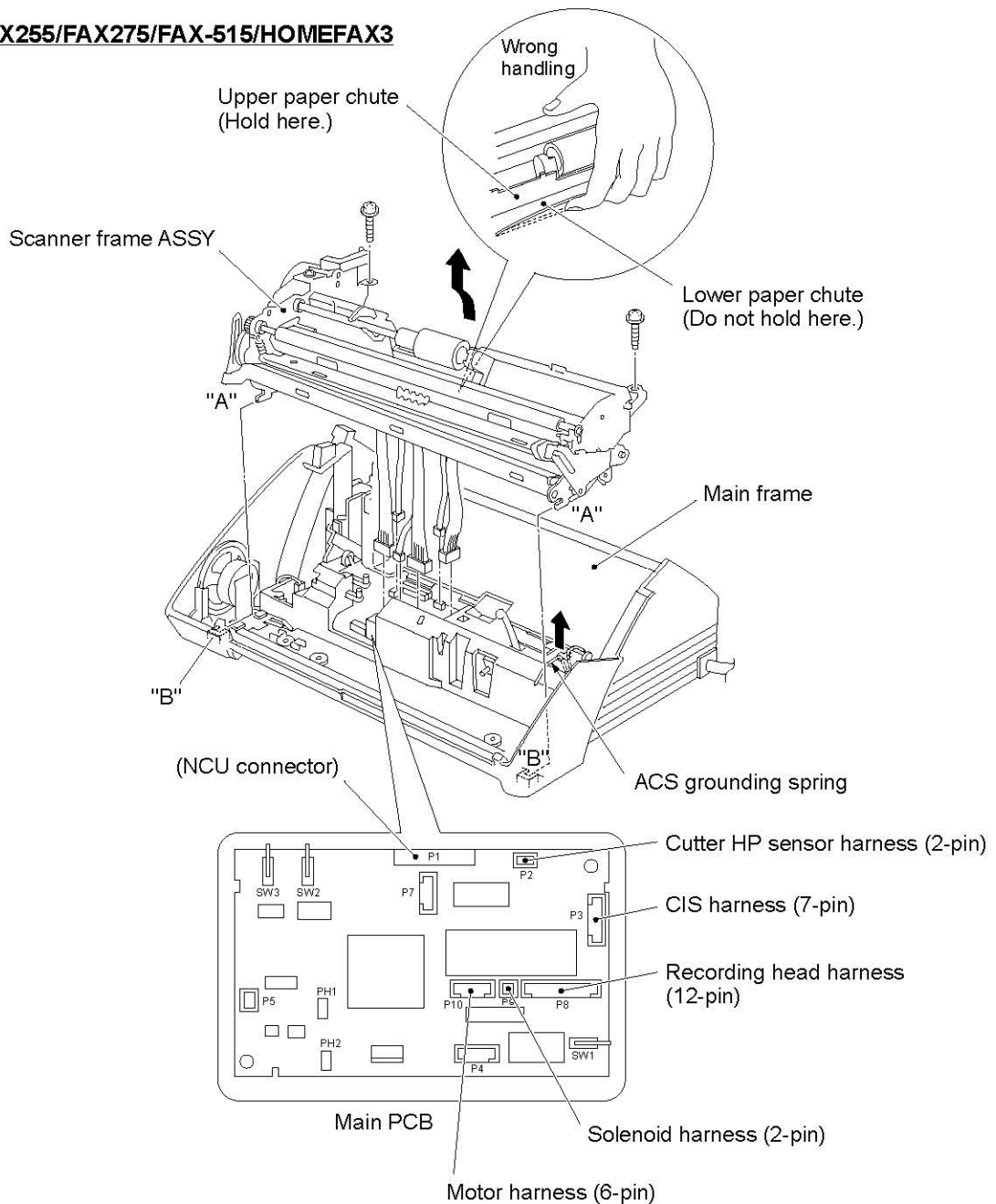

FAX355MC/FAX375MC/FAX-525DT/FAX-525MC

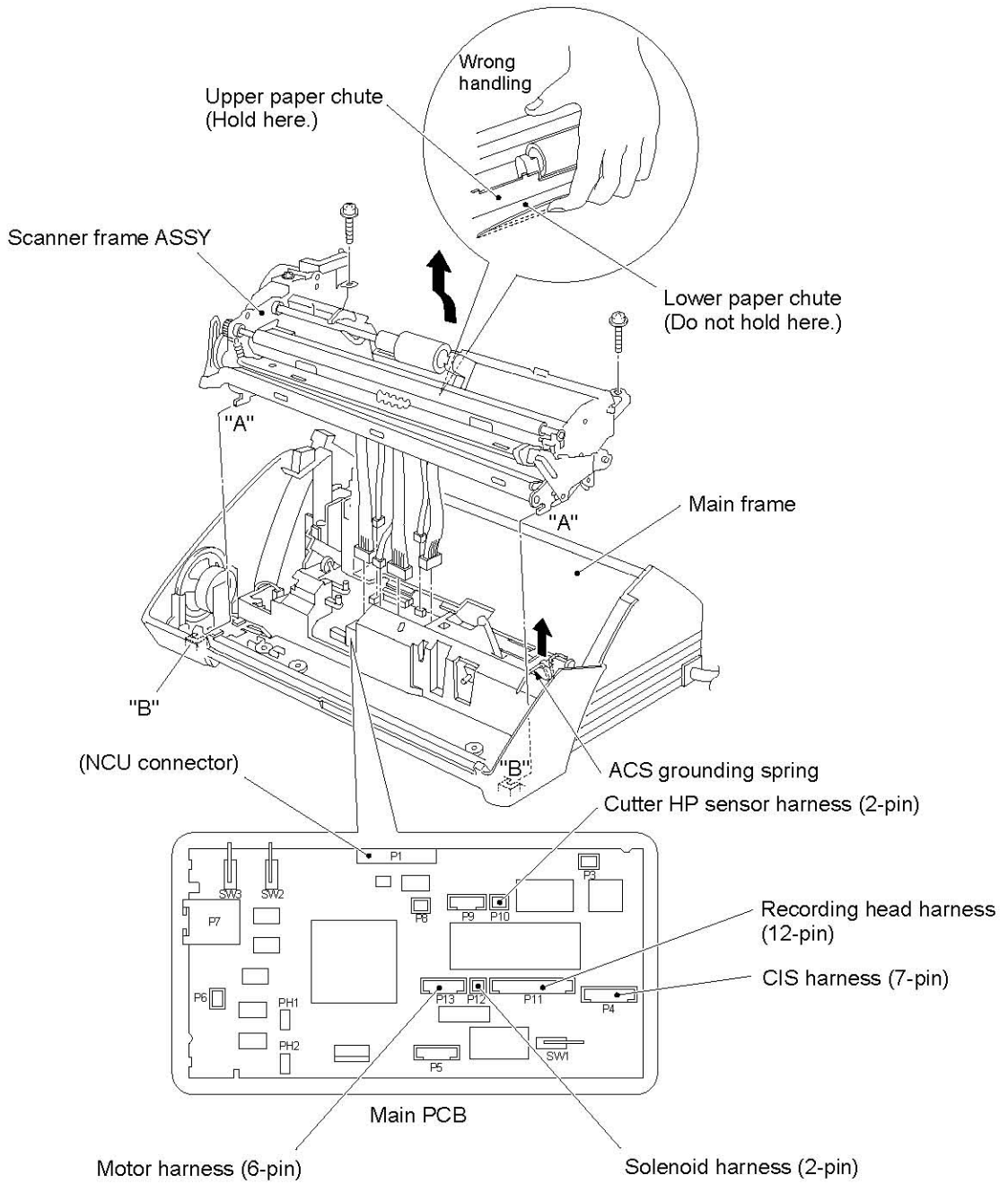

- (5) Lift up the ACS grounding spring.

■ Reassembling Notes

- Before putting the scanner frame ASSY back onto the main frame, be sure to set the ACS grounding spring as illustrated on the previous page.
- Make sure that tabs "A" of the scanner frame ASSY are fitted in cutouts "B" provided in the main frame. (See the illustration on the previous page.)
- For the FAX355MC/FAX375MC/FAX-525DT/FAX-525MC: After putting the scanner frame ASSY back onto the main frame, route the harnesses and arrange the cores as follows, referring to the illustration below.
 - Hook the power supply harness core on boss "C."
 - Check that the cutter HP sensor harness runs through a core, and then hook the core on boss "D."
 - Push the CIS harness core and the recording head harness core into position, to the left of rib "E" and behind relay "F."
 - Route all these harnesses under boss "D."

If any of these harnesses and cores are out of the specified position, the scanner frame ASSY or ROM cover may not be put back into place.

- For the FAX355MC/FAX375MC/FAX-525DT/FAX-525MC: After connecting these harnesses, check that neither the electrolytic capacitor nor resistors are tilted towards the PE sensor actuator. If tilted, they may interfere with normal operation of the sensor actuator.

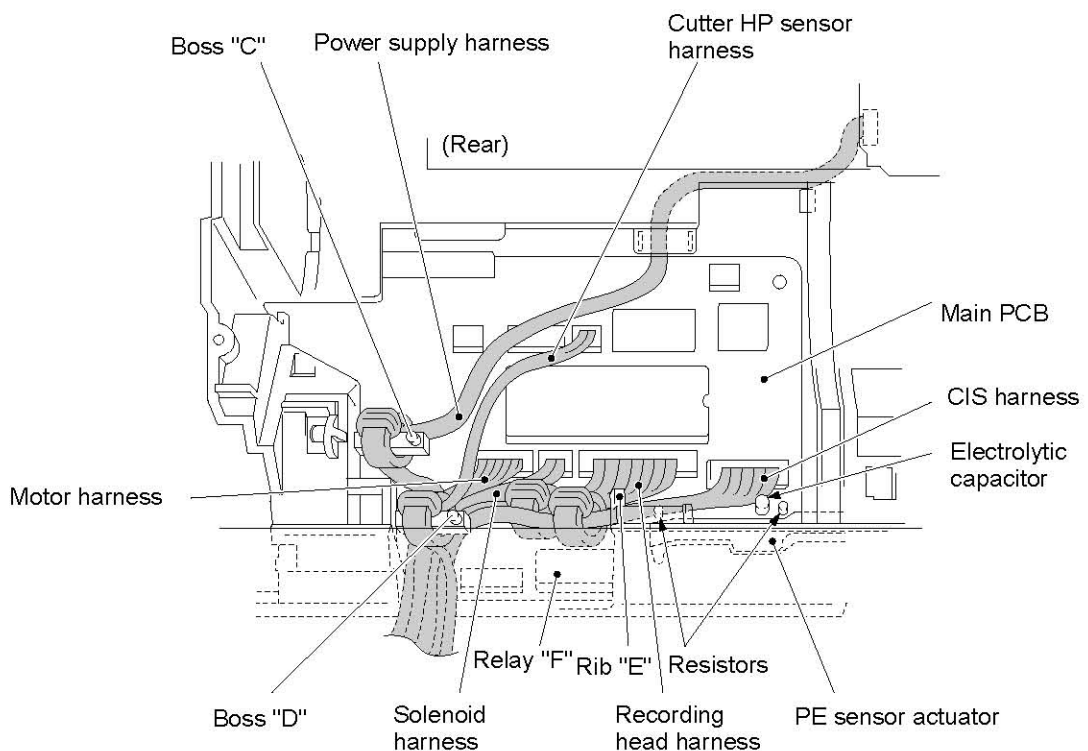

(FAX355MC/FAX375MC/FAX-525DT/FAX-525MC)

1.7 White Pressure Roller and CIS Unit

- (1) Turn the bushing of the white pressure roller clockwise approx. 90° and pull it out to the right.
- (2) Lift up the left end of the white pressure roller and push it to the right.

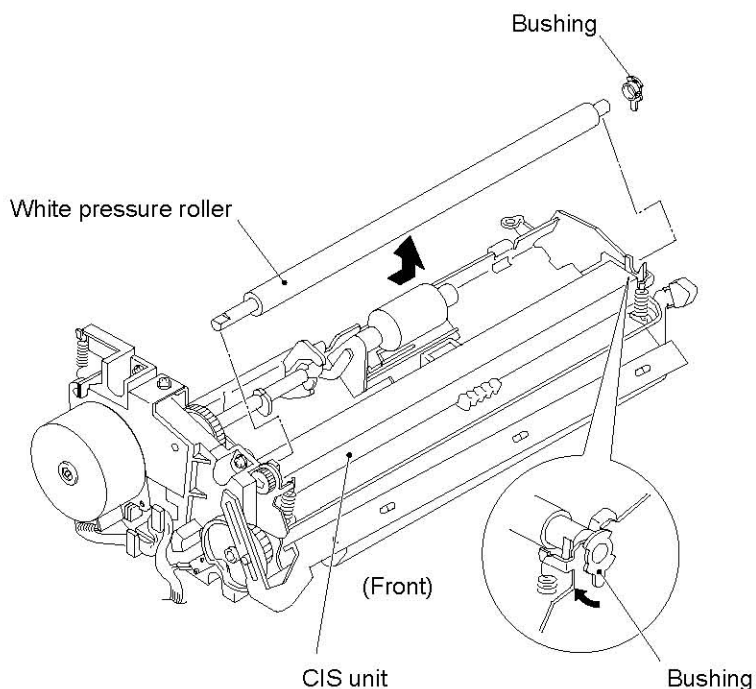

- (3) Unhook the two springs, using the spring hook.
- (4) Slightly lift up the CIS unit and disconnect the CIS harness. The CIS support also comes off.

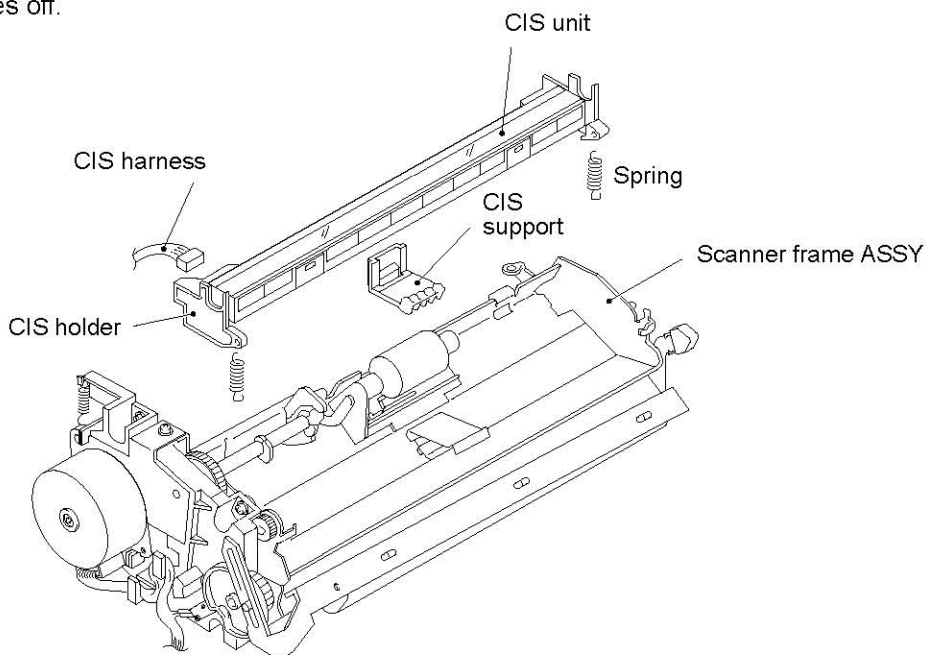

■ Reassembling Notes

- Before putting the white pressure roller back into place, wipe it with an alcohol-dampened cloth.
- When replacing the CIS unit, remove the CIS holders (secured with screws) from the old CIS unit and install them to a new CIS unit.

1.8 Drive Unit (Main Motor and Cutter HP Sensor)

- (1) Turn the scanner frame ASSY upside down.
- (2) Remove the adhesive tape to release the CIS harness, motor harness, solenoid harness, and cutter HP sensor harness.

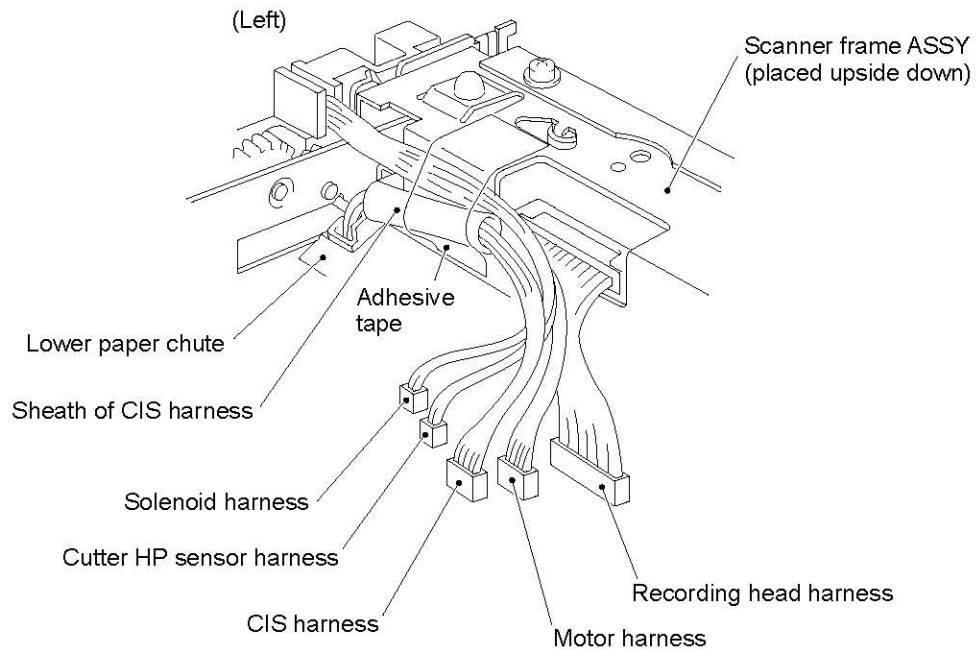

- (3) Place the scanner frame ASSY rightside up.
- (4) Remove the four screws.
- (5) Fully turn the cutter flange clockwise. Hold the drive unit with your left hand and then slightly separate its rear edge from the scanner frame ASSY in the direction of arrow "X" in order to release the boss of the cutter flange from the upper blade.

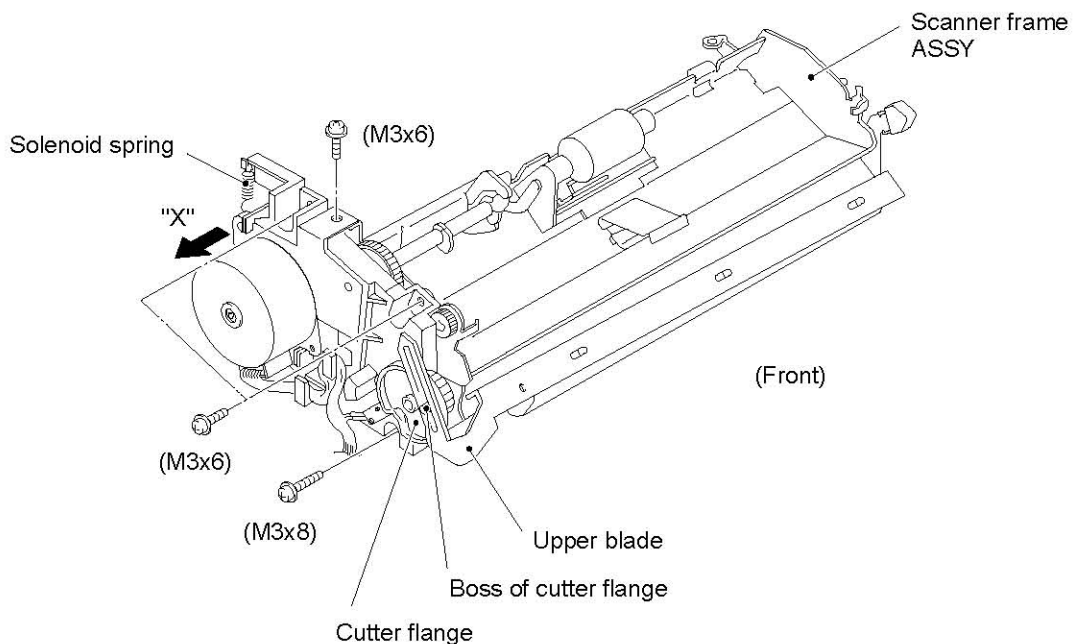

- (6) After releasing the boss of the cutter flange from the upper blade, turn the upper blade clockwise as shown below and take the drive unit off from the scanner frame ASSY.

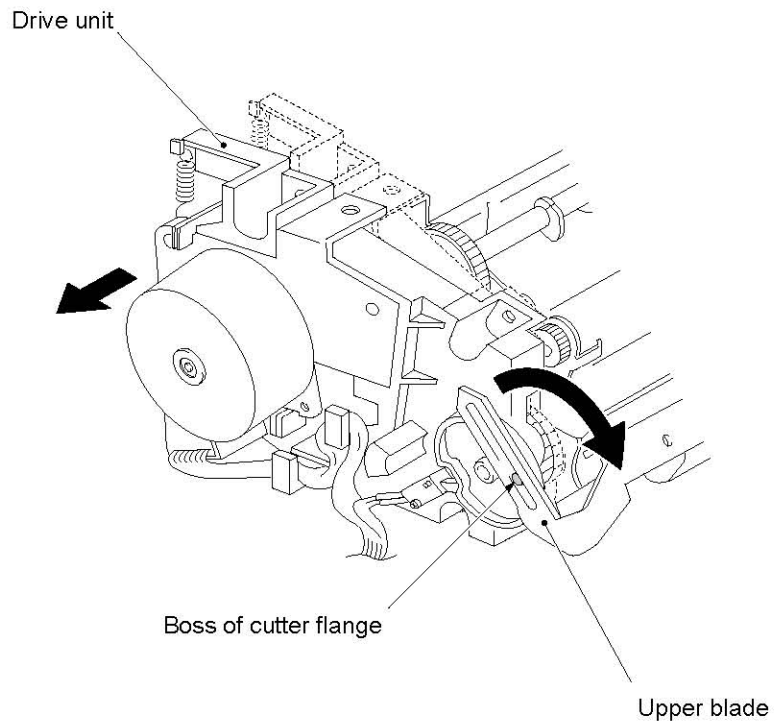

- (7) To take out the motor, remove the screw, lightly press the locking arm and turn the motor counterclockwise. The motor bracket also comes off.

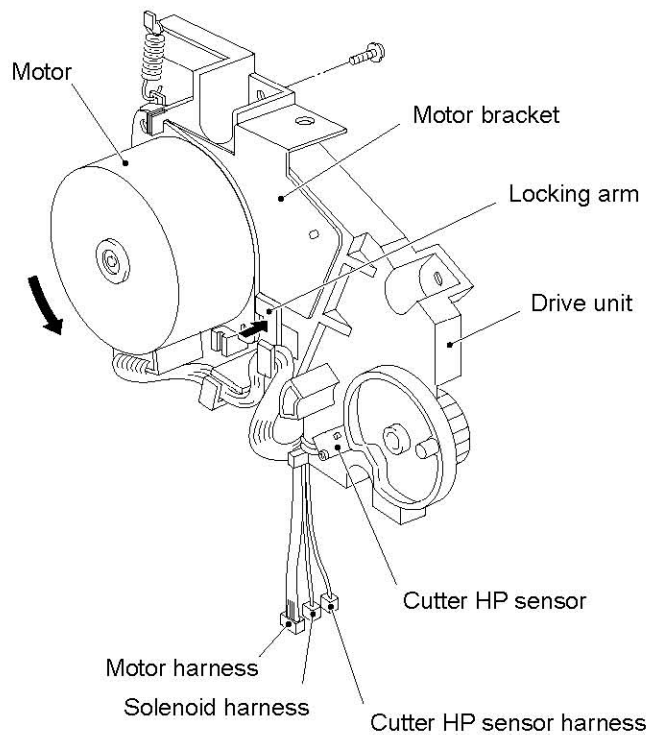

- (8) To take out the cutter HP sensor, remove the screw.

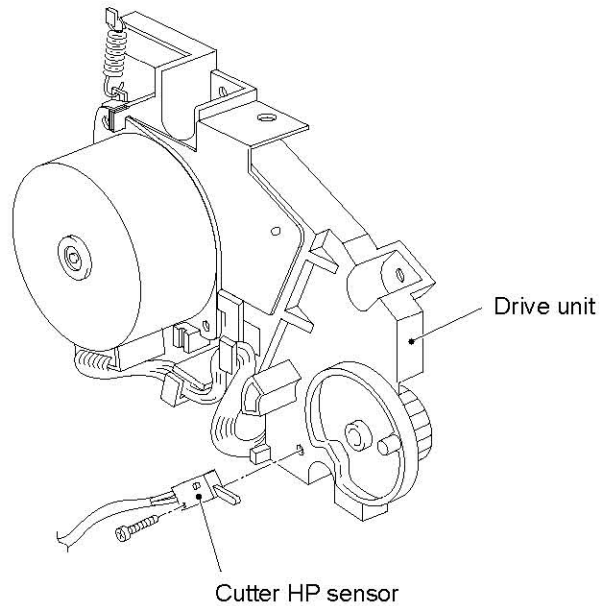

■ **Reassembling Notes**

- When installing the motor bracket, fit the two holes "a" over the positioning bosses provided on the drive unit.
- Make sure that the locking arm clamps the motor.
- When installing the drive unit to the scanner frame ASSY, hold the resin part of the drive unit, taking care not to grip the solenoid spring. Fully turn the cutter flange clockwise and turn the upper blade to the angle shown below, and then fit the boss of the cutter flange into the hole of the upper blade.

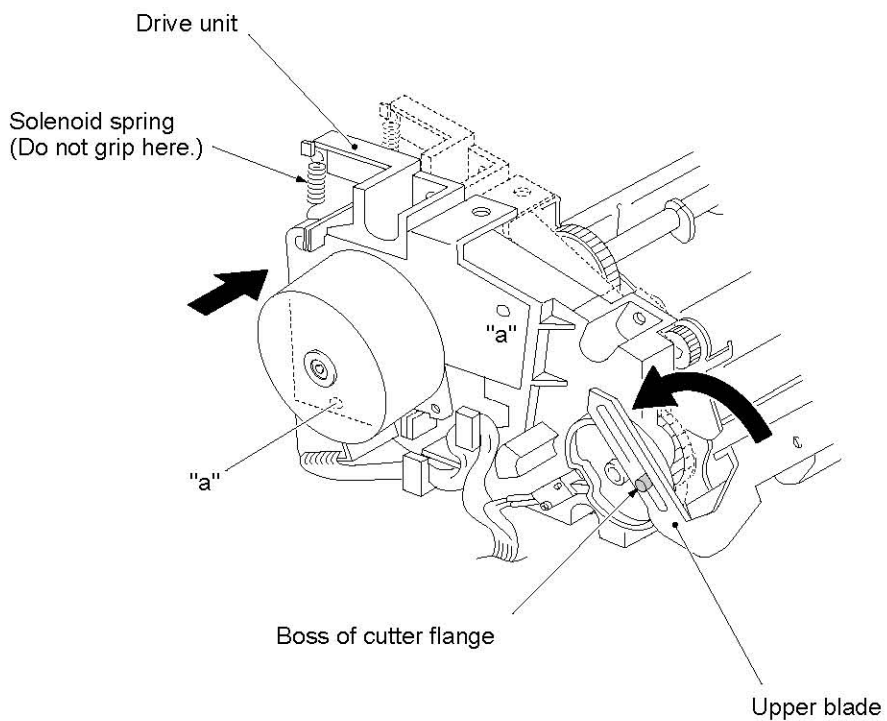

1.9 Separation Roller ASSY

- (1) Push down the latch with the tip of a flat screwdriver and move the separation roller ASSY to the left. Then remove the roller to the right and pull out the roller shaft to the left.

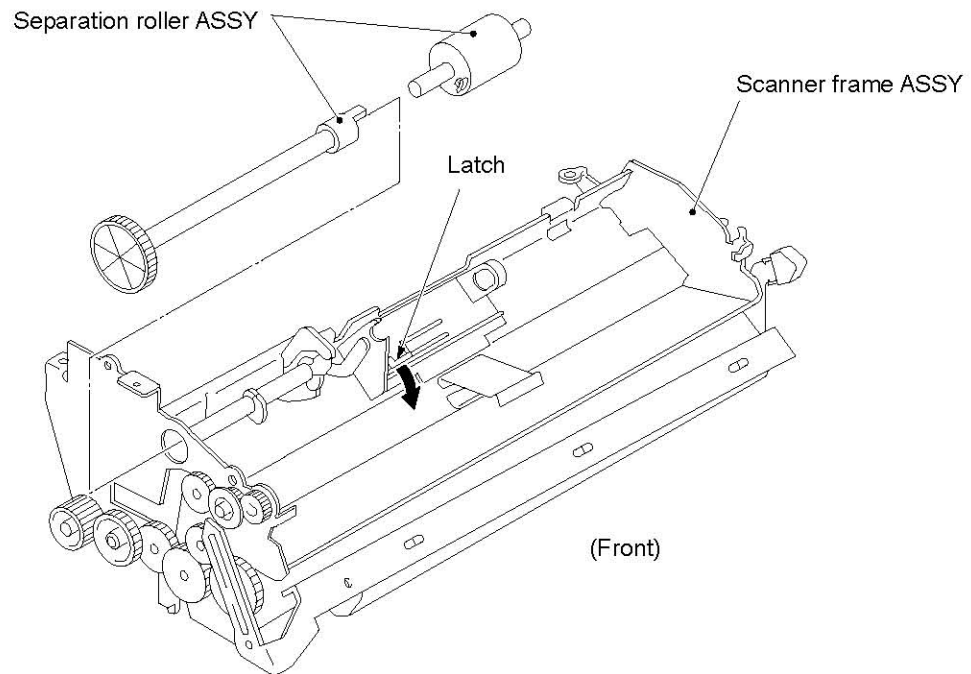

1.10 Document Front and Rear Sensor Actuators

- (1) Turn the document front sensor actuator as shown below and move it to the left (viewed from the rear).

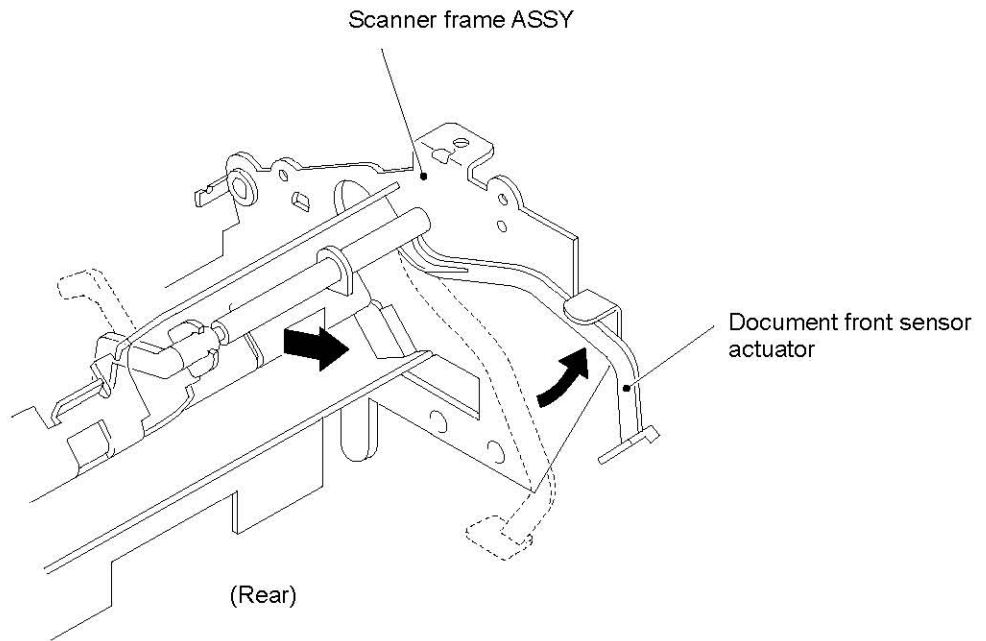

- (2) Turn the document rear sensor actuator as shown below and move it to the right (viewed from the front).

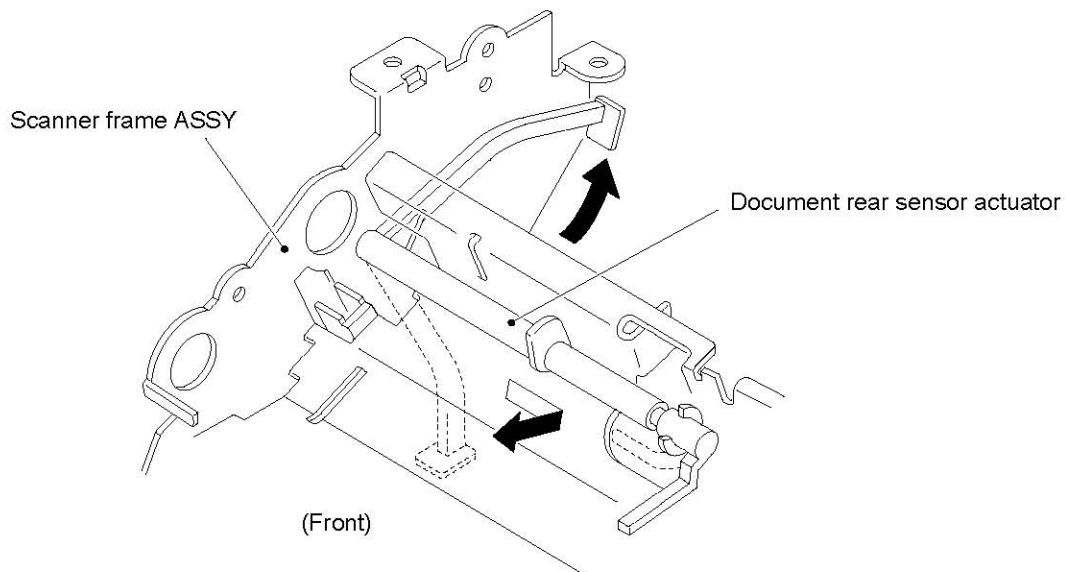

1.11 Recording Head Release Lever

- (1) Place the scanner frame ASSY upside down.
- (2) Swing the recording head release lever as shown below.
- (3) Release the latch and remove the recording head release lever.

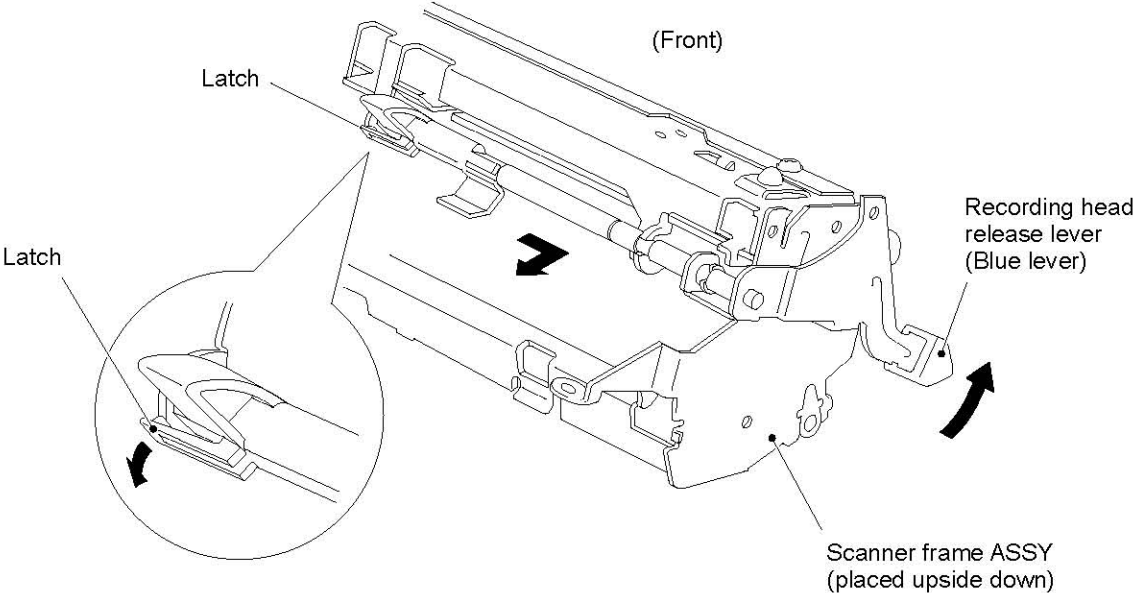

1.12 Recorder & Cutter ASSY

- (1) Place the scanner frame ASSY upside down.
- (2) Remove the screw.
- (3) Press the warped sections of the scanner frame ASSY outwards at both sides with the tip of a flat screwdriver and take out the recorder & cutter ASSY.

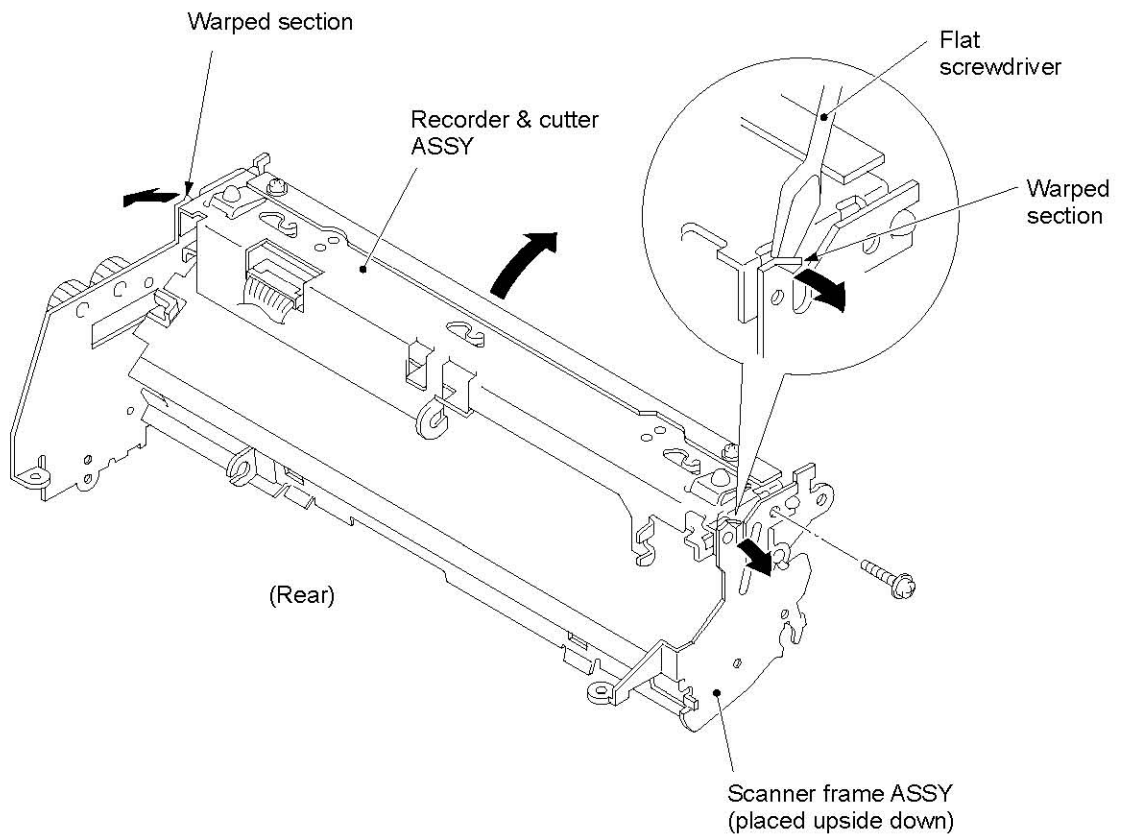

1.13 Platen and Cutter Chute

- (1) Release the latch of the bushing (R) and pull out the bushing to the right.
- (2) Pull out the platen gear to the left together with the platen and then lift up.

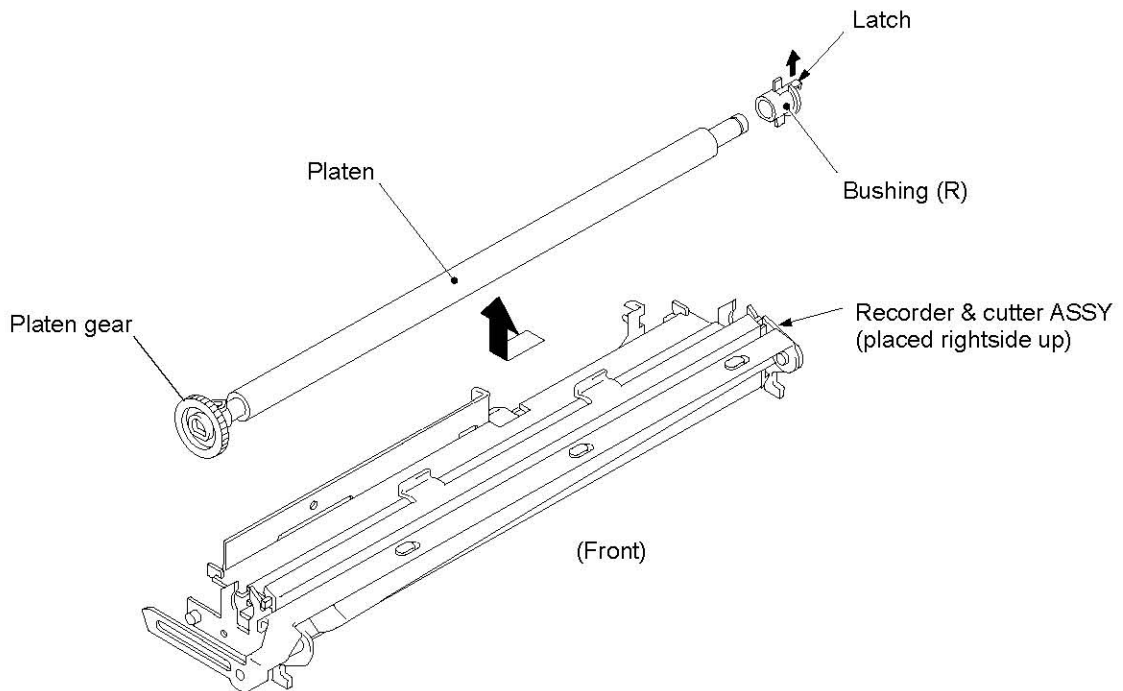

- (3) Press the two latches of the cutter chute inwards to release and then lift up the cutter chute straight, taking care not to let it catch on other parts.

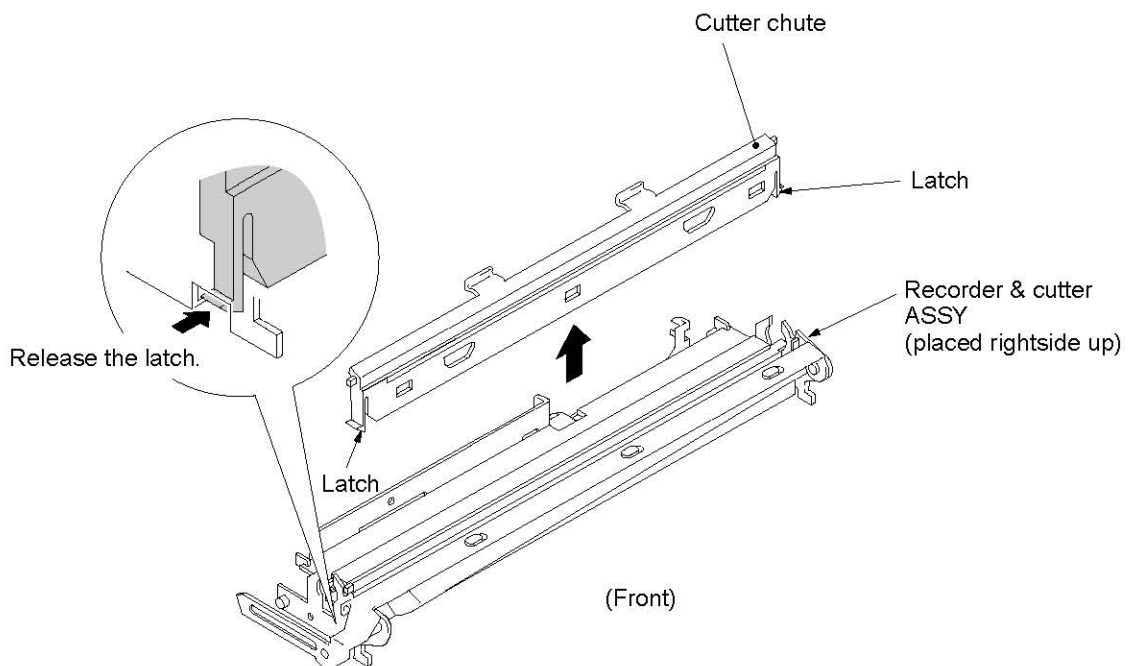

1.14 Recording Head and Cutter Unit

- (1) Push down the front edge of the recording head and move it back to the rear to release the tabs from the cutter unit.

NOTE: Take care not to lose the three springs placed under the recording head.

NOTE: Never disassemble the cutter unit.

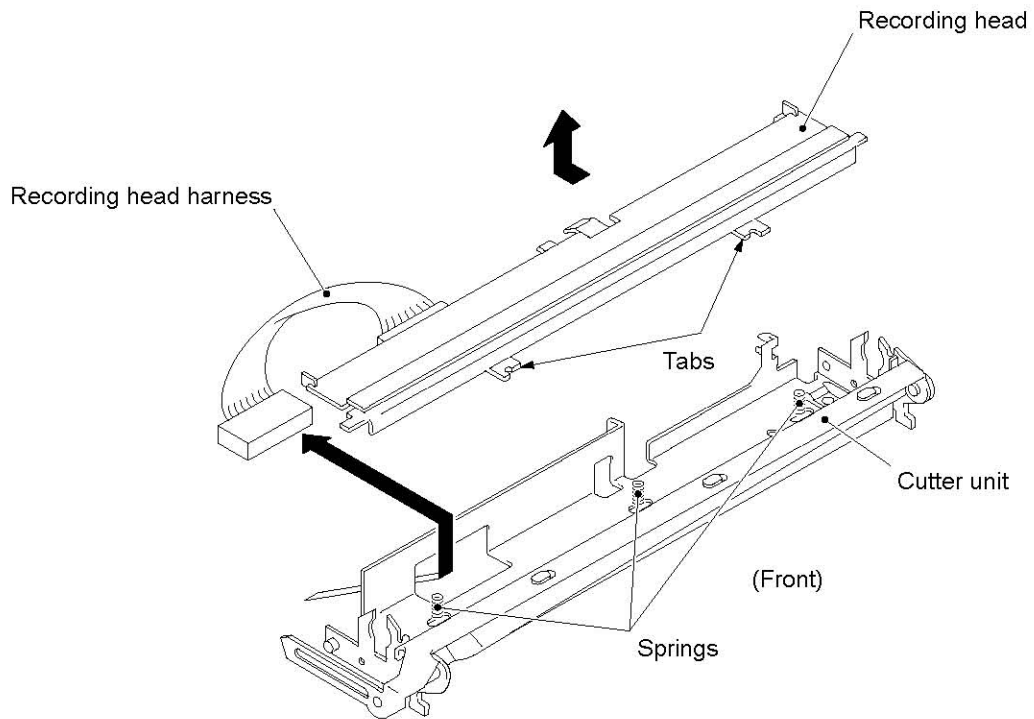

■ Reassembling Notes

- When installing the recording head, make sure that the three springs are set on the bosses of the cutter unit.
- Make sure the recording head harness goes through the cutout provided in the cutter unit.
- It is recommended that you install the platen right after putting the recording head back into place. If not secured by the platen, the recording head could easily come out with any impact.

1.15 Hook Switch Sensor Actuator

- (1) Press the lower section of the hook switch sensor actuator to the left to release the latch from the main frame, then swing it upwards.
- (2) Remove the spring.

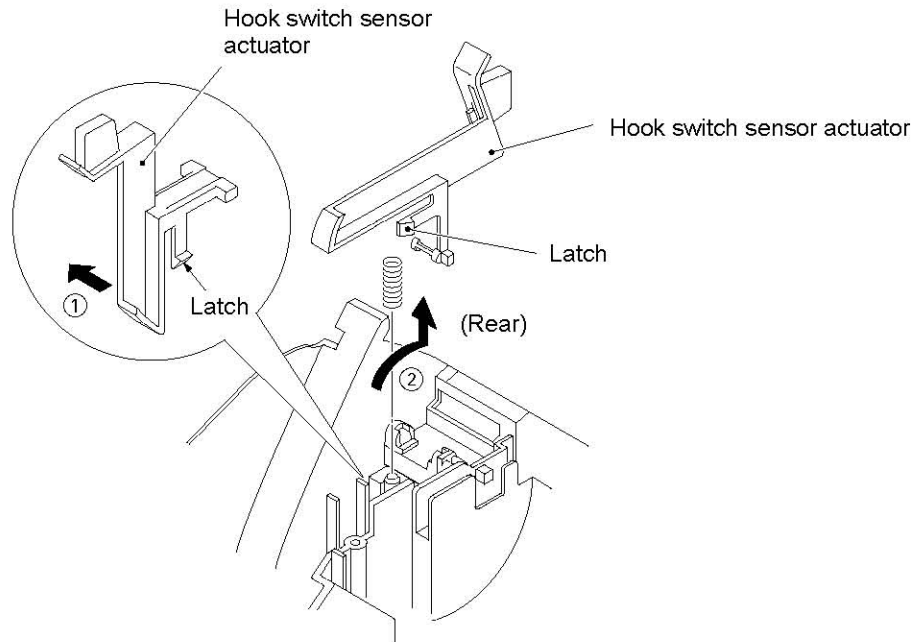

1.16 Speaker

- (1) Disconnect the speaker harness from the main PCB.
- (2) Lift up the speaker.

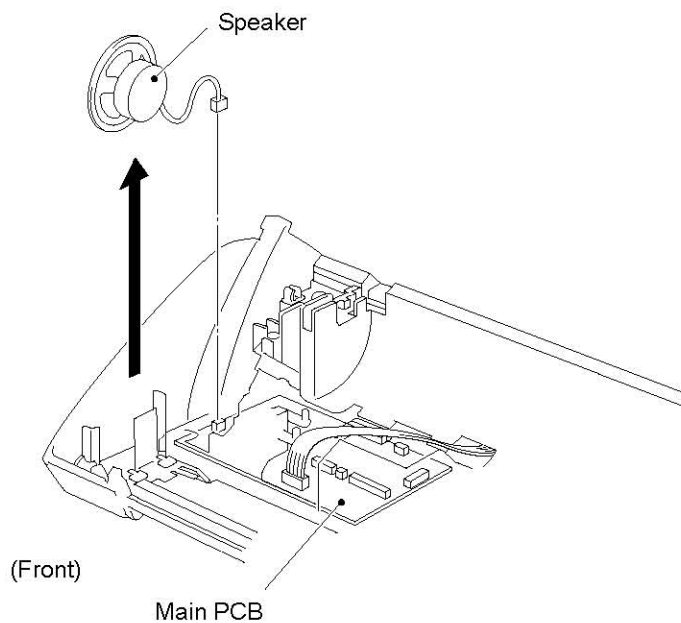

1.17 Bottom Plate

- (1) Place the main frame upside down.
- (2) Remove the four screws.
- (3) Slightly lift up the bottom plate and disconnect the grounding terminal.
- (4) Remove the insulation sheet from the bottom plate.

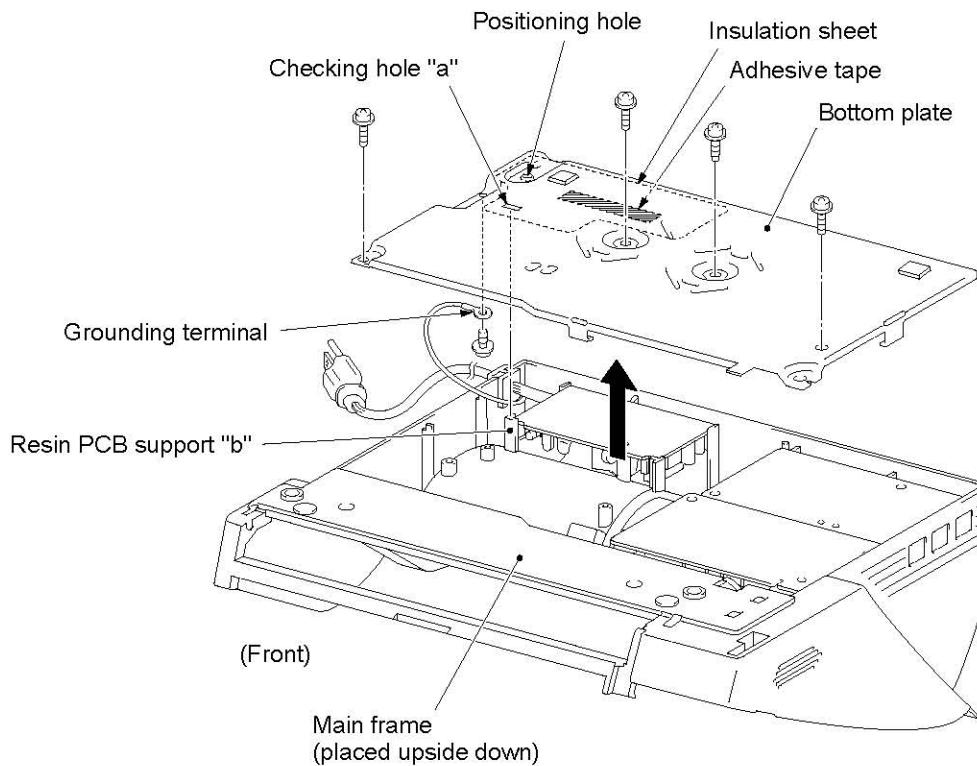

■ Reassembling Notes

- Once removed, the insulation sheet will become unusable and a new one should have to be put back in. When attaching it to the bottom plate, align the rear edge with that of the bottom plate and fit the positioning hole with that provided in the bottom plate, as shown above.
- Before putting the bottom plate back into place, make sure that the power supply PCB is completely fitted in the resin PCB supports without any gap.

After installing the bottom plate, check that resin PCB support "b" of the main frame appears from the checking hole "a" provided in the bottom plate and that the bottom plate is fitted in the main frame without any gap.

If the power supply PCB comes into contact with the bottom plate, a short circuit may occur.

1.18 Main PCB, NCU PCB and Power Supply PCB

If you have already removed the scanner frame ASSY and speaker, slightly lift up the main PCB together with the NCU PCB and then disconnect the power supply harness from the main PCB. If the scanner frame ASSY and speaker are not yet removed, follow the steps below:

FAX255/FAX275/FAX-515/HOMEFAX3

- (1) Slightly lift up the rear edge of the NCU PCB and disconnect it from the main PCB.
- (2) Slightly lift up the rear edge of the main PCB and disconnect the following harnesses from the main PCB:
 - Main-panel harness (5-pin)
 - Cutter home position (HP) sensor harness (2-pin)
 - CIS harness (7-pin)
 - Recording head harness (12-pin)
 - Solenoid harness (2-pin)
 - Motor harness (6-pin)
 - Speaker harness (2-pin)
 - Power supply harness (6-pin)
- (3) Lift up the power supply PCB.

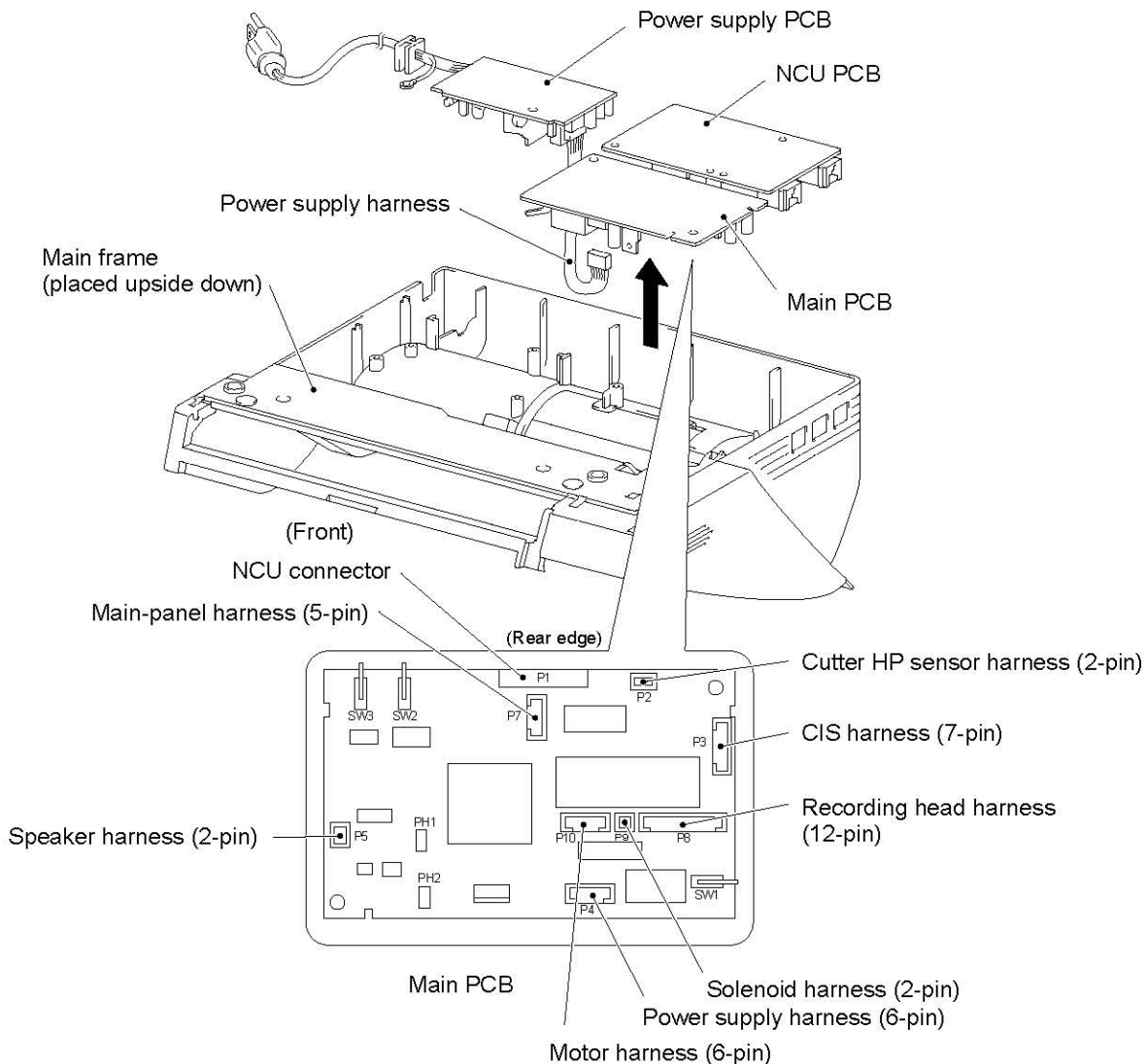

FAX355MC/FAX375MC/FAX-525DT/FAX-525MC

(1) Slightly lift up the rear edge of the NCU PCB and disconnect it from the main PCB.

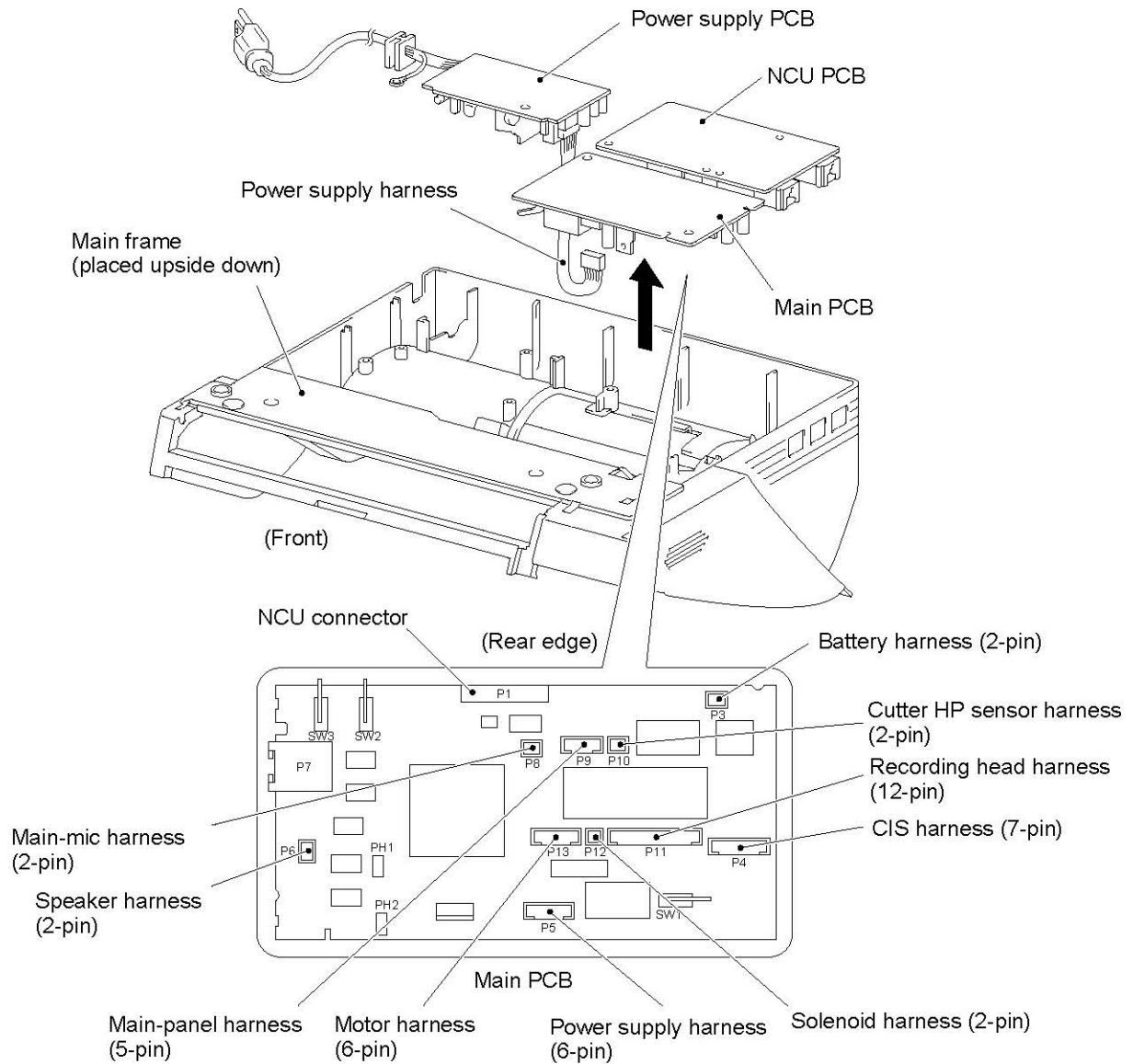

- (2) Attempt to lift up the main PCB slightly. If it is impossible to lift up the PCB to an extent which allows you to disconnect the harnesses, you may not have unhooked the power supply harness core or cutter HP sensor harness core from bosses "C" or "D," respectively. Remove the ROM cover (refer to Section 1.2) and unhook those cores from bosses "C" and "D" illustrated below.

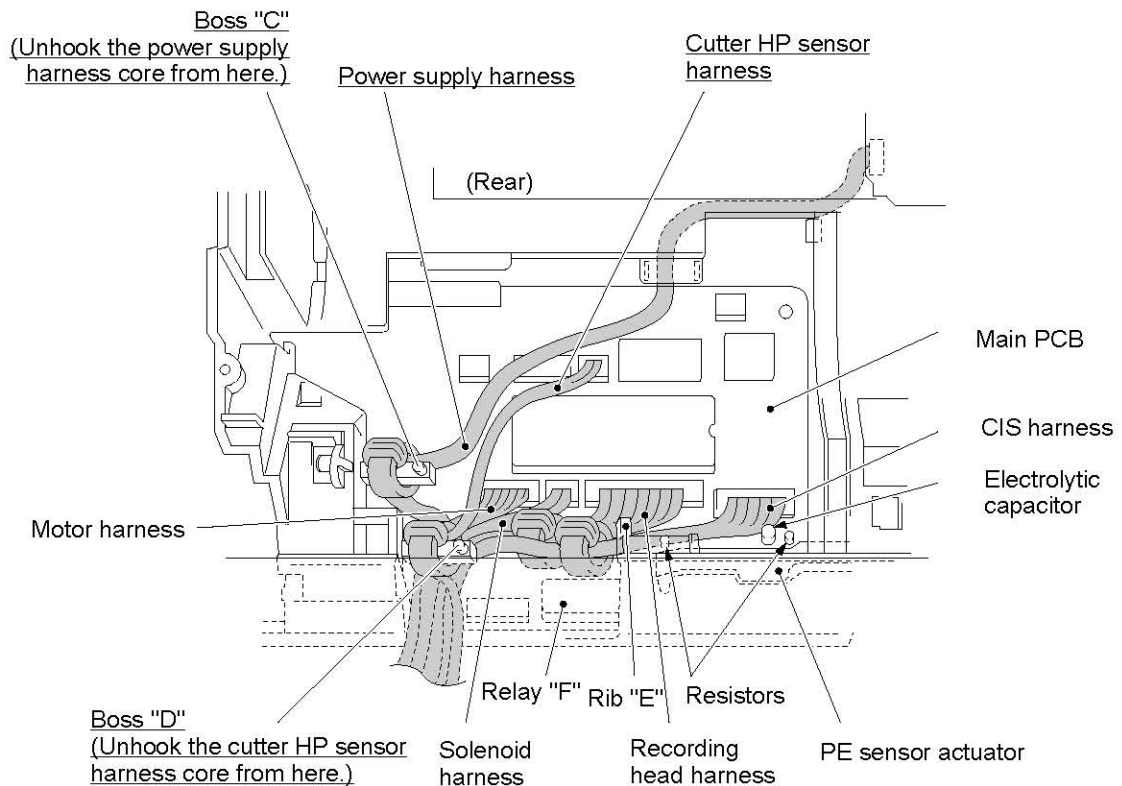

- (3) Slightly lift up the rear edge of the main PCB and disconnect the following harnesses from the main PCB:
- Cutter home position (HP) sensor harness (2-pin)
 - Main-panel harness (5-pin)
 - Main-mic harness (2-pin)
 - Speaker harness (2-pin)
 - Motor harness (6-pin)
 - Power supply harness (6-pin)
 - Solenoid harness (2-pin)
 - Recording head harness (12-pin)
 - CIS harness (7-pin)
- (4) Lift up the power supply PCB.

■ Reassembling Notes

- Make sure that the power supply PCB is completely fitted in the resin PCB supports of the main frame. If it is loosely mounted so that it comes into contact with the bottom plate, a short circuit may occur.
- For the FAX355MC/FAX375MC/FAX-525DT/FAX-525MC: After putting the scanner frame ASSY back onto the main frame, route the harnesses and arrange the cores as follows, referring to the illustration given on the previous page.
 - Hook the power supply harness core on boss "C."
 - Check that the cutter HP sensor harness runs through a core, and then hook the core on boss "D."
 - Push the CIS harness core and the recording head harness core to the left of rib "E" and behind relay "F."
 - Route all these harnesses under boss "D."

If any of these harnesses and cores are out of the specified position, the scanner frame ASSY or ROM cover may not be put back into place.

- For the FAX355MC/FAX375MC/FAX-525DT/FAX-525MC: After connecting these harnesses, check that neither the electrolytic capacitor nor resistors are tilted towards the PE sensor actuator. If tilted, they may interfere with normal operation of the sensor actuator.

1.19 Paper Empty Sensor Actuator

- (1) Press the actuator support outwards and lift up the paper empty sensor actuator. The spring also comes off.

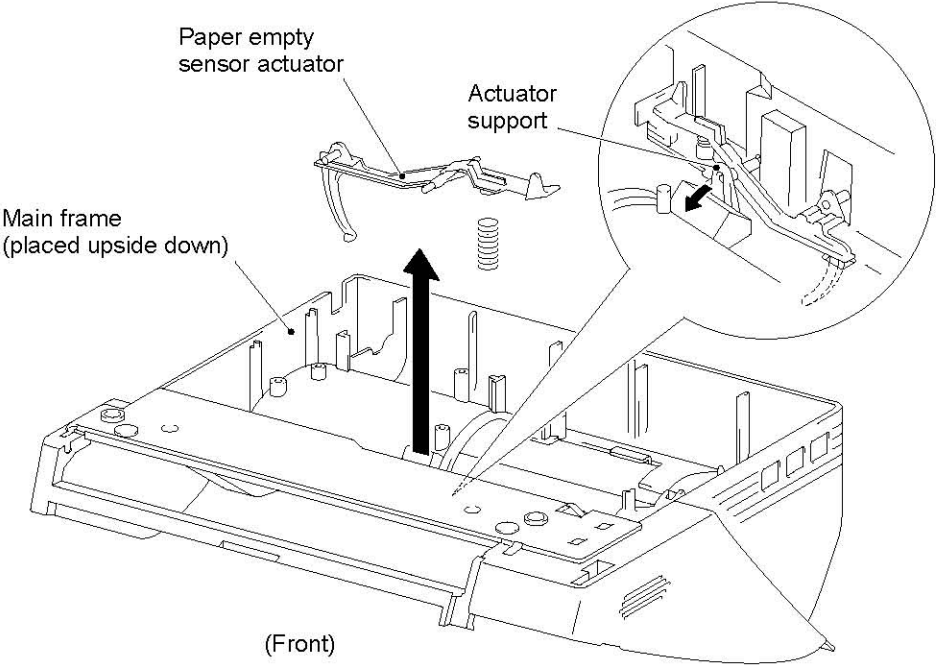

2. LUBRICATION

Apply Molykote EM-30L to the lubrication points as illustrated below.

For points (A), apply a rice-sized pinch of grease (6 mm³).

For points (B), apply a bean-sized pinch of grease (12 mm³).

[1] Scanner frame ASSY

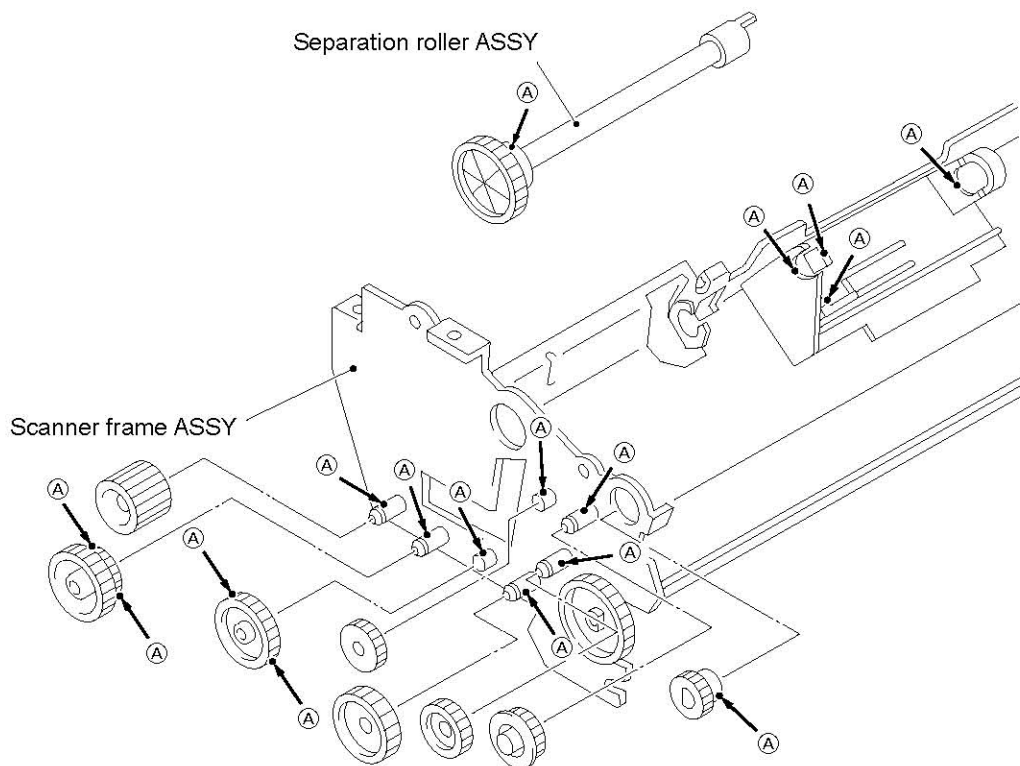

[2] Drive unit

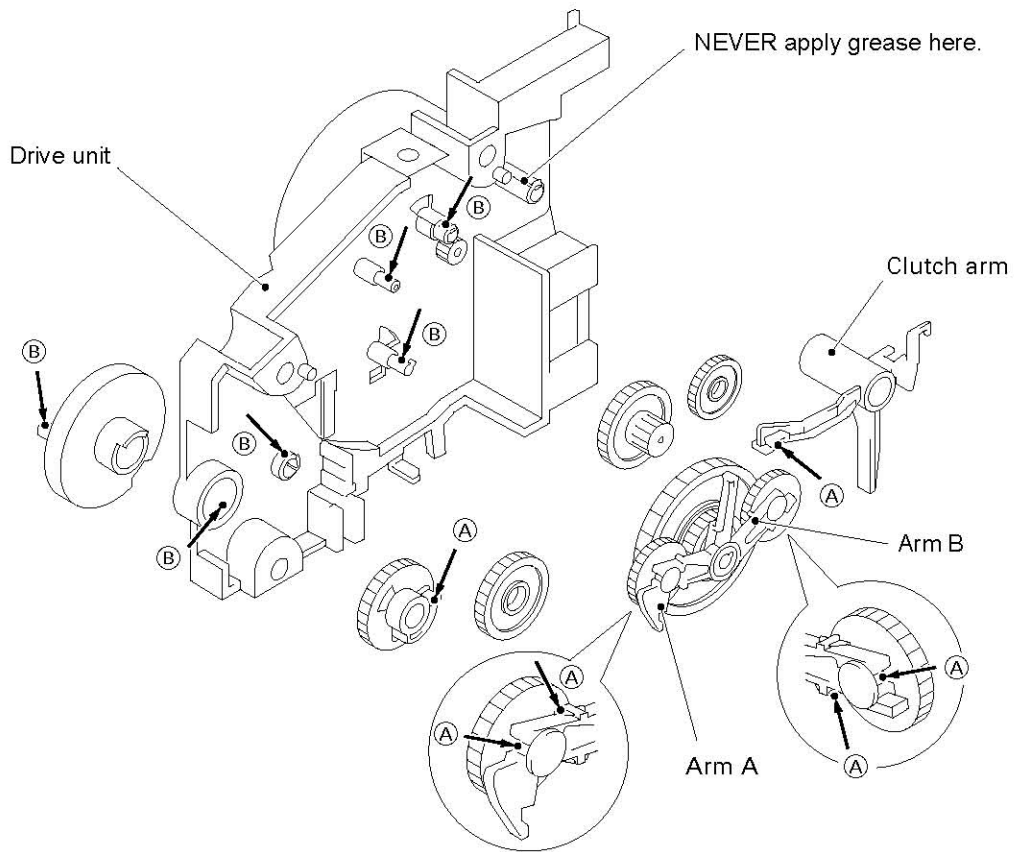

[3] Recording head

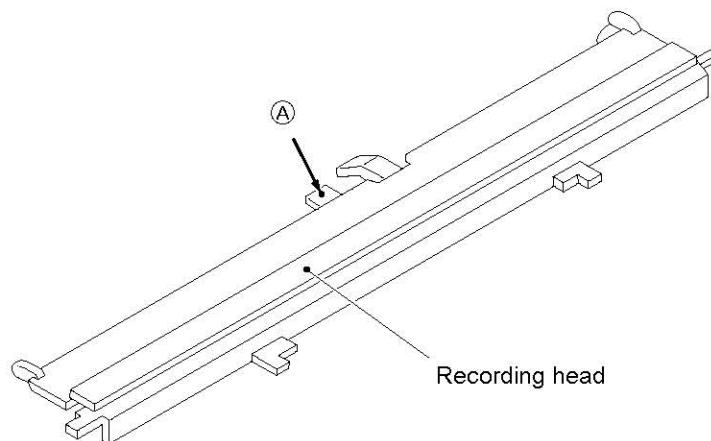

[4] Cutter unit

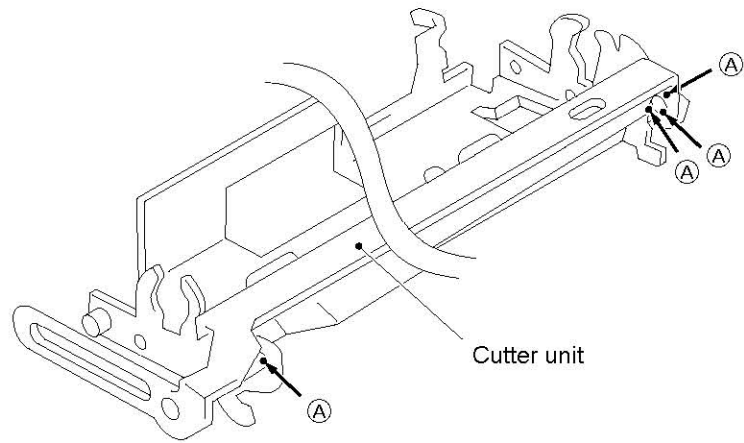

CHAPTER V.

MAINTENANCE MODE

CHAPTER V. MAINTENANCE MODE

CONTENTS

1.	ENTRY INTO THE MAINTENANCE MODE.....	V-1
2.	LIST OF MAINTENANCE-MODE FUNCTIONS	V-2
3.	DETAILED DESCRIPTION OF MAINTENANCE-MODE FUNCTIONS	V-4
3.1	EEPROM Parameter Initialization.....	V-4
3.2	Printout of Scanning Compensation Data	V-5
3.3	ADF Performance Test.....	V-7
3.4	Test Pattern 1.....	V-8
3.5	Firmware Switch Setting and Printout	V-9
3.6	Operational Check of LCD.....	V-51
3.7	Operational Check of Control Panel PCB	V-51
3.8	Sensor Operational Check.....	V-53
3.9	Fine Adjustment of Scanning Start/End Position.....	V-54
3.10	CIS Scanner Area Setting.....	V-55
3.11	EEPROM Customizing	V-55
3.12	Equipment Error Code Indication.....	V-56
3.13	Output of Transmission Log to the Telephone Line	V-56
3.14	Document Draw Adjustment	V-57

1. ENTRY INTO THE MAINTENANCE MODE

FAX255/FAX275/FAX355MC/FAX375MC: To make the facsimile equipment enter the maintenance mode, press the **Function**, *, **2**, **8**, **6**, and **4** keys in this order.

← Within 2 seconds →

FAX-515/FAX-525DT/FAX-525MC/HOMEFAX3: To make the facsimile equipment enter the maintenance mode, press the **Menu**, *, **2**, **8**, **6**, and **4** keys in this order.

← Within 2 seconds →

The equipment beeps for approx. one second and displays " ■■ MAINTENANCE ■■■ " on the LCD, indicating that it is placed in the initial stage of the maintenance mode, a mode in which the equipment is ready to accept entry from the keys.

To select one of the maintenance-mode functions listed in Section 2, enter the corresponding 2-digit function code with the numerical keys on the control panel. (The details of each maintenance-mode function are described in Section 3.)

- NOTES:**
- Pressing the **9** key twice in the initial stage of the maintenance mode makes the equipment exit from the maintenance mode, restoring it to the standby state.
 - Pressing the **Stop** button after entering only one digit restores the equipment to the initial stage of the maintenance mode.
 - If an invalid function code is entered, the equipment resumes the initial stage of the maintenance mode.

2. LIST OF MAINTENANCE-MODE FUNCTIONS

Maintenance-mode Functions

Function Code	Function	Reference Subsection (Page)
01	EEPROM Parameter Initialization	3.1 (V-4)
02	_____	_____
03	_____	_____
04	_____	_____
05	Printout of Scanning Compensation Data	3.2 (V-5)
06	_____	_____
07	_____	_____
08	ADF* Performance Test	3.3 (V-7)
09	Test Pattern 1	3.4 (V-8)
10	Firmware Switch Setting	3.5 (V-9)
11	Printout of Firmware Switch Data	3.5 (V-50)
12	Operational Check of LCD	3.6 (V-51)
13	Operational Check of Control Panel PCB (Check of Keys and Buttons)	3.7 (V-51)
32	Sensor Operational Check	3.8 (V-53)
54	Fine Adjustment of Scanning Start/End Position	3.9 (V-54)
55	CIS Scanner Area Setting	3.10 (V-55)
74	EEPROM Customizing	3.11 (V-55)
82	Equipment Error Code Indication	3.12 (V-56)
87	Output of Transmission Log to the Telephone Line	3.13 (V-56)
91	EEPROM Parameter Initialization (except the telephone number storage area)	3.1 (V-4)
99	Exit from the Maintenance Mode	--- (V-1)
----	Document Draw Adjustment	3.14 (V-57)

* ADF: Automatic document feeder

----- **IMPORTANT** -----

Basically, the maintenance-mode functions listed on the previous page should be accessed by service personnel only. However, you may allow end users to access some of these under the guidance of service personnel (e.g., by telephone).

The user-accessible functions (codes 10, 11, 12, 82, 87 and 91) are shaded in the table given on the previous page. Function code 10 accesses the firmware switches WSW01 to WSW37, each of which has eight selectors. You should not allow end users to access all of those selectors, but you may allow them to access user-accessible selectors which are shaded in the firmware switch tables in Subsection 3.5.

The service personnel should instruct end users to follow the procedure given below.

- (1) FAX255/FAX275/FAX355MC/FAX375MC: Press the **Function** and **Mode** keys in this order.
 FAX-515/FAX-525DT/FAX-525MC/HOMEFAX3: Press the **Menu** and **Mode** keys in this order.

The LCD clears the current display.

NOTE: The **Mode** key is inoperable during standby for redialing and timer.

- (2) Press the **0** key.
- (3) Enter the desired function code (10, 11, 12, 82, 87, or 91) with the numerical keys.
 For function code 10, access the desired firmware switch according to the operating procedure described in Subsection 3.5.
- (4) To make the equipment return to the standby state, press the **Stop** key.

FAX255/FAX275/FAX355MC/FAX375MC

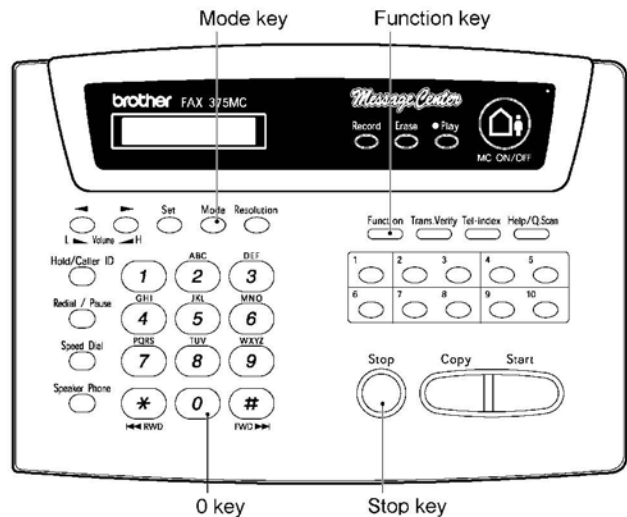

FAX-515/FAX-525DT/FAX-525MC/HOMEFAX3

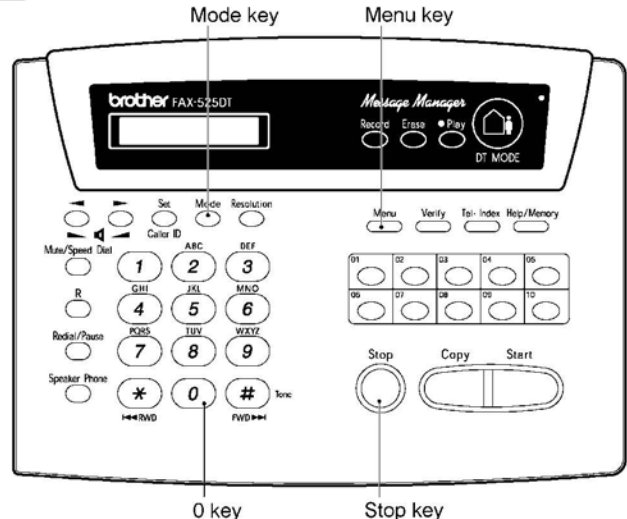

3. DETAILED DESCRIPTION OF MAINTENANCE-MODE FUNCTIONS

3.1 EEPROM Parameter Initialization

■ Function

The equipment initializes the parameters, user switches, and firmware switches registered in the EEPROM, to the initial values. Entering the function code 01 initializes all of the EEPROM areas, but entering 91 does not initialize some areas, as listed below.

Data item \ Function code	01	91
Maintenance-mode functions User switches Firmware switches Remote activation code Activity report Distinctive ringing patterns registered	All of these will be initialized	These will be initialized
Station ID data Outside line number Remote access code FAX forwarding/paging Telephone function registration One-touch dialing Speed dialing Group dialing		These will <u>not</u> be initialized
EEPROM customizing code (4-digit)	This will <u>not</u> be initialized. (Note that the first digit of the 4-digit code will be initialized to "0." If the code is <u>1</u> 001, for example, it will be initialized to <u>0</u> 001.)	

NOTE: If you replace the main PCB with one used for other facsimile equipment, carry out this procedure and then customize the EEPROM (maintenance-mode function code 74 in Section 3.11).

■ Operating Procedure

- (1) Press the **0** and **1** keys (or the **9** and **1** keys according to your need) in this order in the initial stage of the maintenance mode.
The "PARAMETER INIT" will appear on the LCD.
- (2) Upon completion of parameter initialization, the equipment returns to the initial stage of the maintenance mode.

3.2 Printout of Scanning Compensation Data

■ Function

The equipment prints out the white and black level data for scanning compensation.

■ Operating Procedure

Do not start this function merely after powering on the equipment but start it after carrying out a sequence of scanning operation. Unless the equipment has carried out any scanning operation, this function cannot print out correct scanning compensation data. This is because at the start of scanning operation, the equipment initializes white and black level data and takes in the scanning compensation reference data.

- (1) Press the **0** and **5** keys in this order in the initial stage of the maintenance mode.
The "WHITE LEVEL 1" will appear on the LCD.
- (2) The equipment prints out the scanning compensation data list containing the following:
 - a) White level data (208 bytes)
 - b) Black level data (1 byte)
 - c) Initial clamp PWM value (1 byte)
 - d) Clamp PWM value (1 byte)
 - e) Compensation data for background color (1 byte)
 - f) Limitation value for compensation data (1 byte)
 - g) Initial LED light intensity value (1 byte)
 - h) LED light intensity value (1 byte)
 - i) LED light intensity value on the platen and documents (2 bytes)
 - j) Threshold value on the platen (1 byte)
 - k) Document rear sensor adjustment value (1 byte)
- (3) Upon completion of recording of the compensation data list, the equipment returns to the initial stage of the maintenance mode.

NOTE: If any data is abnormal, its code will be printed in inline style, as shown on the next page.

- a) 5F00 : 39 3F 3F 3D 3D 3B 3B 3B 3D 3D 3D 39 39 39 3B 3D
5F10 : 2D 23 11 1D 11 1C 1C 13 23 23 23 23 23 23 23 23
5F20 : 23 23 23 0F 11 11 16 11 11 21 23 23 23 23 2A 2A
5F30 : 1A 23 1D 18 23 18 1A 13 1C 23 13 18 16 18 16 16
5F40 : 13 1A 15 13 1F 21 1A 1F 1D 24 23 24 28 1C 24 2A
5F50 : 26 1F 21 21 24 24 15 1F 1D 1A 1D 21 1A 1F 24 26
5F60 : 24 24 23 1F 16 18 1A 18 18 16 18 1A 1D 1A 1C 18
5F70 : 18 18 0E 16 13 0E 18 1A 1A 15 16 16 0C 13 18 1F
5F80 : 1C 1C 15 18 13 13 15 13 1A 15 1A 11 1D 0C 18 11
5F90 : 11 16 13 13 0E 1D 1D 0F 18 0C 11 1C 1D 1D 11 15
5FA0 : 0C 1D 16 0E 18 2B 1A 2D 16 18 24 1C 26 23 15 11
5FB0 : 16 1A 0F 0E 0F 23 0F 0F 18 1D 1D 26 2D 2D 36 3B
5FC0 : 39 38 39 39 3B 3D 3D 3B 38 38 36 38 39 3D 3B 3B
- b) 5F00 : 00
c) 5F00 : 21
d) 5F00 : 00
e) 5F00 : 00
f) 5F00 : 45
g) 5F00 : 35
h) 5F00 : 22
i) 5F00 : 00 00
j) 5F00 : FF
k) 5F00 : 55

Scanning Compensation Data List

3.3 ADF Performance Test

■ Function

The equipment counts the documents fed by the automatic document feeder (ADF) and displays the count on the LCD for checking the ADF performance.

■ Operating Procedure

- (1) Set documents (Allowable up to the ADF capacity) in the initial stage of the maintenance mode.
The "DOC. READY" will appear on the LCD.
- (2) Press the **0** and **8** keys in this order.
The equipment
 - i) copies the 1st document and displays "COPY P.01 STD" on the LCD.
 - ii) feeds in and out the 2nd through 4th documents while counting without copying them as the LCD shows the corresponding count,
 - iii) copies the 5th document and displays "COPY P.05 STD" on the LCD,
 - iv) feeds in and out the 6th through 9th documents while counting without copying them as the LCD shows the corresponding count, and
 - v) copies the 10th document and displays "COPY P.10 STD" on the LCD.
- (3) Upon completion of feeding in and out all of the documents, the final count appears on the LCD.
- (4) Press the **Stop** key to return the equipment to the initial maintenance mode.

3.4 Test Pattern 1

■ Function

This function, much like the copying function, prints out test pattern 1 to allow the service personnel to check for record data missing or print quality.

■ Operating Procedure

Press the **0** and **9** keys in this order in the initial stage of the maintenance mode.

The figure below shows test pattern 1.

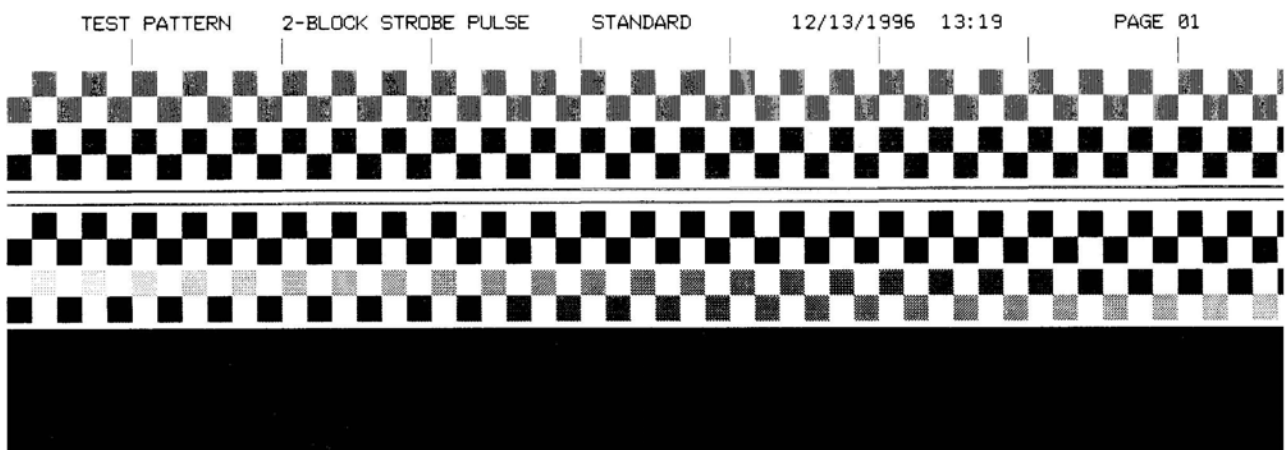

Test Pattern 1

3.5 Firmware Switch Setting and Printout

[A] Firmware switch setting

■ Function

The facsimile equipment incorporates the following firmware switch functions (WSW01 through WSW37) which may be activated with the procedures using the control panel keys and buttons. The firmware switches have been set at the factory in conformity to the communications standards and codes of each country. Do not disturb them unless necessary. Some firmware switches may not be applicable in some versions. The firmware switch data list indicates "Not used." for those inapplicable switches.

Firmware Switches (WSW01 through WSW37)

WSW No.	Function	Reference Page
WSW01	Dial pulse setting	V-11
WSW02	Tone signal setting	V-12
WSW03	PABX mode setting	V-13
WSW04	TRANSFER facility setting	V-15
WSW05	1st dial tone and busy tone detection	V-16
WSW06	Pause key setting and 2nd dial tone detection	V-18
WSW07	Dial tone setting 1	V-20
WSW08	Dial tone setting 2	V-21
WSW09	Protocol definition 1	V-22
WSW10	Protocol definition 2	V-23
WSW11	Busy tone setting	V-24
WSW12	Signal detection condition setting	V-25
WSW13	Modem setting	V-26
WSW14	AUTO ANS facility setting	V-27
WSW15	REDIAL facility setting	V-28
WSW16	Function setting 1	V-29
WSW17	Function setting 2	V-30
WSW18	Function setting 3	V-31
WSW19	Transmission speed setting	V-32
WSW20	Overseas communications mode setting	V-33
WSW21	TAD setting 1	V-34
WSW22	ECM setting	V-35
WSW23	Communications setting	V-36
WSW24	TAD setting 2	V-37
WSW25	TAD setting 3	V-38
WSW26	Function setting 4	V-39
WSW27	Function setting 5	V-40
WSW28	Function setting 6	V-41
WSW29	Function setting 7	V-42
WSW30	Function setting 8	V-43
WSW31	Function setting 9	V-44
WSW32	Function setting 10	V-45
WSW33	Function setting 11	V-46
WSW34	Function setting 12	V-47
WSW35	Function setting 13	V-48
WSW36	Function setting 14	V-48
WSW37	Function setting 15	V-49

■ Operating Procedure

- (1) Press the **1** and **0** keys in this order in the initial stage of the maintenance mode.
The equipment displays the "WSW00" on the LCD and becomes ready to accept a firmware switch number.
- (2) Enter the desired number from the firmware switch numbers (01 through 37).
The following appears on the LCD:
$$\text{WSWXX} = \underline{0} 0 0 0 0 0 0 0$$
- (3) Use the **◀** and **▶** keys to move the cursor to the selector position to be modified.
- (4) Enter the desired number using the **0** and **1** keys.
- (5) Press the **Set** key. This operation saves the newly entered selector values onto the EEPROM and readies the equipment for accepting a firmware switch number.
- (6) Repeat steps (2) through (5) until the modification for the desired firmware switches is completed.
- (7) Press the **Set** or **Stop** key to return the equipment to the initial stage of the maintenance mode.

- NOTES:**
- To cancel this operation and return the equipment to the initial stage of the maintenance mode during the above procedure, press the **Stop** key.
 - If there is a pause of more than one minute after a single-digit number is entered for double-digit firmware switch numbers, the equipment will automatically return to the initial stage of the maintenance mode.

■ Note

The user-accessible selectors of the firmware switches are shaded in the tables given on the following pages.

■ Detailed Description for the Firmware Switches

WSW01 (Dial pulse setting)

Selector No.	Function	Setting and Specifications
1 2	Dial pulse generation mode	No. 1 2 0 0 : N 0 1 : N+1 1 0 : 10-N 1 1 : N
3 4	Break time length in pulse dialing	No. 3 4 0 0 : 60 ms 0 1 : 67 ms 1 0 : 40 ms (for 16 PPS) 1 1 : 64 ms (at 106-ms intervals)
5 6	Inter-digit pause	No. 5 6 0 0 : 800 ms 0 1 : 850 ms 1 0 : 950 ms 1 1 : 600 ms
7	Switching between pulse (DP) and tone (PB) dialing, by the function switch	0: Yes 1: No
8	Default dialing mode, pulse (DP) or tone (PB) dialing	0: PB 1: DP

● Selectors 1 and 2: Dial pulse generation mode

These selectors set the number of pulses to be generated in pulse dialing.

- N: Dialing "N" generates "N" pulses. (Dialing "0" generates 10 pulses.)
- N + 1: Dialing "N" generates "N + 1" pulses.
- 10 - N: Dialing "N" generates "10 - N" pulses.

● Selectors 3 and 4: Break time length in pulse dialing

These selectors set the break time length in pulse dialing.

(Example: If "1," "2," and "3" are dialed when N is set by selectors 1 and 2.)

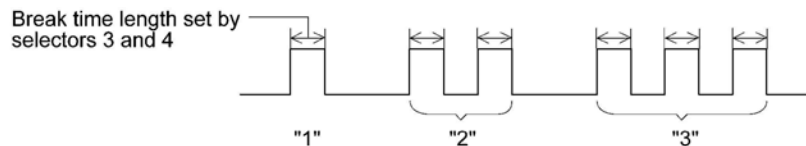

● Selectors 5 and 6: Inter-digit pause

These selectors set the inter-digit pause in pulse dialing.

(Example: If "1," "2," and "3" are dialed when N is set by selectors 1 and 2.)

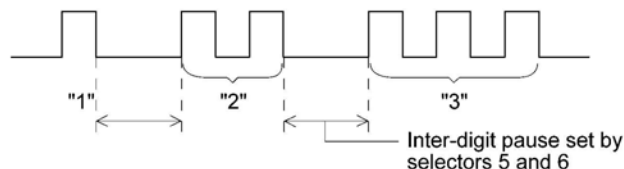

- **Selector 7: Switching between pulse (DP) and tone (PB) dialing, by the function switch**

This selector determines whether or not the dialing mode may be switched between the pulse (DP) and tone (PB) dialing by using the function switch.

- **Selector 8: Default dialing mode, pulse (DP) or tone (PB) dialing**

This selector sets the default dialing mode (pulse dialing or tone dialing) which may be changed by the function switch. If the user switches it with the function switch when selector 7 is set to "0," the setting specified by this selector will also be switched automatically.

WSW02 (Tone signal setting)

Selector No.	Function	Setting and Specifications
1 2	Tone signal transmission time length	No. 1 2 0 0 : 70 ms 0 1 : 80 ms 1 0 : 90 ms 1 1 : 100 ms
3 4	Min. pause in tone dialing	No. 3 4 0 0 : 70 ms 0 1 : 80 ms 1 0 : 90 ms 1 1 : 140 ms
5 8	Attenuator for pseudo ring backtone to the line (selectable in the range of 0-15 dB)	0: 0 dB 1: 8 dB 0: 0 dB 1: 4 dB 0: 0 dB 1: 2 dB 0: 0 dB 1: 1 dB

- **Selectors 1 through 4: Tone signal transmission time length and Min. pause in tone dialing**

These selectors set the tone signal transmission time length and minimum pause in tone dialing.

(Example: If "1," "2," "3," "4," and "5" are dialed.)

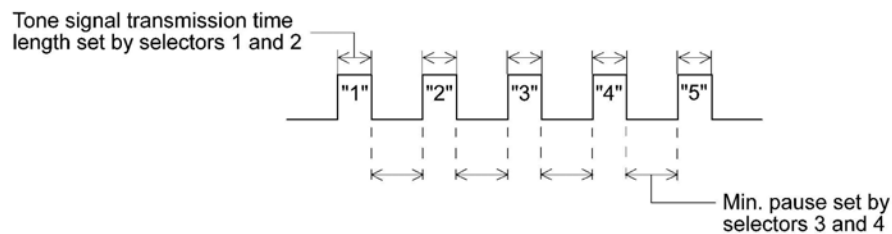

- **Selectors 5 through 8: Attenuator for pseudo ring backtone to the line**

These selectors are used to adjust the sound level of beep generated as a ring backtone in the F/T mode or as a signal during remote control operation or at the start of ICM recording.

Setting two or more selectors to "1" produces addition of attenuation assigned to each selector. This setting will be limited if selector 8 of WSW23 is set to "0."

WSW03 (PABX* mode setting)

Selector No.	Function	Setting and Specifications
1	CNG detection when sharing a modular wall socket with a telephone	0: A 1: B
2 4	Min. detection time length of PABX* dial tone, required for starting dialing	No. 2 3 4 0 0 0 : 50 ms 0 0 1 : 210 ms 0 1 0 : 500 ms 0 1 1 : 800 ms 1 0 0 : 900 ms 1 0 1 : 1.5 sec. 1 1 0 : 2.0 sec. 1 1 1 : 2.5 sec.
5	CNG detection when sharing a modular wall socket with a telephone	0: A 1: B
6 7	Dial tone detection in PABX*	No. 6 7 0 0 : No detection (3.5 sec. WAIT) 0 1 : No detection (5 sec. WAIT) 1 0 : No detection (7 sec. WAIT) 1 1 : Detection (Frequency only)
8	"R" key function	0: 1st dial tone detection add 1: No 1st dial tone detection

* PABX: Private automatic branch exchange

NOTE: Selectors 2 through 4 and 6 through 8 are not applicable where no PABX is installed.

● **Selectors 1 and 5: CNG detection when sharing a modular wall socket with a telephone**

These selectors determine whether or not the equipment detects a CNG signal when a line is connected to a telephone sharing a modular wall socket with the equipment. Upon detection of CNG signals by the number of cycles specified by these selectors, the equipment interprets CNG as an effective signal and then starts FAX reception.

Selector		Cycle
No. 1	No. 5	
0 (A)	0 (A)	0.5 cycle
0 (A)	1 (B)	1.0 cycle
1 (B)	0 (A)	1.5 cycles
1 (B)	1 (B)	2.0 cycles

● **Selectors 2 through 4: Min. detection time length of PABX dial tone, required for starting dialing**

Upon detection of the PABX dial tone for the time length set by these selectors, the equipment starts dialing.

These selectors are effective only when both selectors 6 and 7 are set to "1" (Detection).

- **Selectors 6 and 7: Dial tone detection in PABX**

These selectors activate or deactivate the dial tone detection function which detects a dial tone when a line is connected to the PABX.

Setting both of these selectors to "1" activates the dial tone detection function so that the equipment starts dialing upon detection of a dial tone when a line is connected.

Other setting combinations deactivate the dial tone detection function so that the equipment starts dialing after the specified WAIT (3.5, 5.0, or 7.0 sec.) without detection of a dial tone when a line is connected.

- **Selector 8: "R" key function**

This selector determines whether or not the 1st dial tone detection function (specified by selectors 1 through 3 of WSW05) is added to the R key.

If this selector is set to "0," pressing the R key automatically activates the 1st dial tone detection function when the PABX and the automatic calling are selected by using the function switch. If you press the R key and a dial number in succession, the equipment will automatically carry out the 1st dial tone detection function following the original transfer function as shown below.

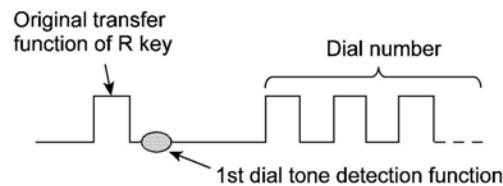

WSW04 (TRANSFER facility setting)

Selector No.	Function	Setting and Specifications
1	Earth function in transfer facility	0: Provided 1: Not provided
2 3	Dual tone detection frequency in ICM recording	No. 2 3 0 0 : 350 and 440 Hz (A) 0 1 : 440 and 480 Hz (B) 1 x : 480 and 620 Hz (C)
4	Tone detection sensitivity in ICM recording	0: OFF 1: High
5 6	Earth time length for earth function	No. 5 6 0 0 : 200 ms 0 1 : 300 ms 1 0 : 500 ms 1 1 : 700 ms
7 8	Break time length for flash function	No. 7 8 0 0 : 80 ms 0 1 : 110 ms 1 0 : 250 ms 1 1 : 500 ms

NOTE: Selectors 1 and 5 through 8 are not applicable in those countries where no transfer facility is supported.

NOTE: Selectors 2 through 4 are applicable to those models equipped with a built-in TAD.

NOTE: Selectors 2 and 3 are applicable in the U.S.A.

- **Selector 1: Earth function in transfer facility**

This selector determines whether or not the earth function is added to the transfer setting menu to be accessed by the function switch.

- **Selectors 2 and 3: Dual tone detection frequency in ICM recording**

If the equipment detects either of the frequencies set by these selectors in ICM recording, it will disconnect the line. For example, if these selectors are set to "0, 0," the equipment will disconnect the line upon detection of 350 Hz or 440 Hz.

- **Selectors 4: Tone detection sensitivity in ICM recording**

Setting this selector to "1" increases the tone detection sensitivity in ICM recording.

- **Selectors 5 and 6: Earth time length for earth function**

These selectors set the short-circuiting time length of the telephone line (La or Lb) to ground.

This setting is effective only when the earth function is selected for the R key by using the function switch.

- **Selectors 7 and 8: Break time length for flash function**

These selectors set the break time length.

This setting is effective only when the flash function is selected for the R key by using the function switch.

WSW05 (1st dial tone and busy tone detection)

Selector No.	Function	Setting and Specifications
1 3	1st dial tone detection	No. 1 2 3 0 0 0 : 3.5 sec. WAIT 0 0 1 : 7.0 sec. WAIT 0 1 0 : 10.5 sec. WAIT 0 1 1 : 14.0 sec. WAIT 1 0 0 : 17.5 sec. WAIT 1 0 1 : 21.0 sec. WAIT 1 1 0 : 24.5 sec. WAIT 1 1 1 : Detection (Without WAIT)
4	Max. pause time allowable for remote ID code detection	0 : 2 seconds 1: 1 second
5 6	Busy tone detection in auto-automatic sending mode	No. 5 6 0 0 : No detection 0 1 : Detection only after dialing 1 0 : No detection 1 1 : Detection before and after dialing
7	Busy tone detection in auto-automatic receiving mode	0 : Yes 1: No
8	Not used.	

NOTE: Selectors 5 through 7 are not applicable in those countries where no busy tone detection is supported, e.g., China.

● **Selectors 1 through 3: 1st dial tone detection**

These selectors activate or deactivate the 1st dial tone detection function which detects the 1st dial tone issued from the PSTN when a line is connected to the PSTN.

Setting all of these selectors to "1" activates the dial tone detection function so that the equipment starts dialing upon detection of a dial tone when a line is connected. (However, in those countries which support no dial tone detection function, e.g., in the U.S.A., setting these selectors to "1" makes the equipment start dialing after a WAIT of 3.5 seconds.) For the detecting conditions of the 1st dial tone, refer to WSW07 and WSW08.

Other setting combinations deactivate the dial tone detection function so that the equipment starts dialing after the specified WAIT (3.5, 7.0, 10.5, 14.0, 17.5, 21.0, or 24.5 seconds) without detection of a dial tone when a line is connected to the PSTN.

- **Selector 4: Max. pause time allowable for remote ID code detection**

This selector sets the maximum pause time allowable for detecting the second digit of a remote ID code after detection of the first digit in remote reception.

If selector 4 is set to "0" (2 seconds), for instance, only a remote ID code whose second digit is detected within 2 seconds after detection of the first digit will become effective so as to activate the remote function.

- **Selectors 5 and 6: Busy tone detection in automatic sending mode**

These selectors determine whether or not the equipment automatically disconnects a line upon detection of a busy tone in automatic sending mode.

Setting selector 6 to "0" ignores a busy tone so that the equipment does not disconnect the line.

Setting selectors 5 and 6 to "0" and "1," respectively, makes the equipment detect a busy tone only after dialing and disconnect the line.

Setting both of selectors 5 and 6 to "1" makes the equipment detect a busy tone before and after dialing and then disconnect the line.

- **Selector 7: Busy tone detection in automatic receiving mode**

This selector determines whether or not the equipment automatically disconnects a line upon detection of a busy tone in automatic receiving mode.

WSW06 (Pause key setting and 2nd dial tone detection)

Selector No.	Function	Setting and Specifications
1 3	Pause key setting and 2nd dial tone detection	No.1 2 3 0 0 0 : No pause 0 0 1 : 3.5 sec. WAIT 0 1 0 : 7 sec. WAIT 0 1 1 : 10.5 sec. WAIT 1 0 0 : 14 sec. WAIT 1 1 0 : 2nd dial tone detection only in pulse dialing (DP) system 1 0 1 : } 2nd dial tone detection 1 1 1 : } both in DP and push-button (PB) dialing system
4 6	Detection of international tone	No.4 5 6 0 0 0 : 50 ms 0 0 1 : 210 ms 0 1 0 : 500 ms 0 1 1 : 800 ms 1 0 0 : 900 ms 1 0 1 : 1.5 sec. 1 1 0 : 2.0 sec. 1 1 1 : 2.5 sec.
7	No. of 2nd dial tone detection times	0: Once 1: Twice
8	2nd dial tone interrupt detecting time	0: 30 ms 1: 50 ms

NOTE: Selectors 4 through 8 are not applicable in those countries where no dial tone detection is supported, e.g., U.S.A.

- **Selectors 1 through 3: Pause key setting and 2nd dial tone detection**

Selectors			
1	2	3	
0	0	0	No WAIT is inserted even if the Pause key is pressed.
0	0	1	If you press the Pause key during dialing, the facsimile equipment will insert WAIT as defined in the above table. If the Pause key is pressed repeatedly, the equipment inserts the specified WAIT multiplied by the number of depressions. It applies also in hook-up dialing.
0	1	0	
0	1	1	
1	0	0	
1	0	1	When these selectors are set to "1, 0, 1": If you press the Pause key during dialing, the equipment will wait for the 2nd dial tone to be sent via the communications line. When these selectors are set to "1, 1, 0" or "1, 1, 1": If you press the Pause key during dialing, the equipment will first wait for the 2nd dial tone to be sent via the communications line. After that, the equipment will insert a WAIT of 3.5 seconds. If no 2nd dial tone is received within the specified time length (set by WSW08), the equipment will disconnect the line if in automatic dialing, or it will start transmitting the dial signal if given after depression of the Pause key in hook-up dialing. (In those countries where no dial tone detection function is supported, setting these selectors to "1, 1, 0," "1, 0, 1," or "1, 1, 1" inserts a WAIT of 3.5 seconds.)
1	1	0	
1	1	1	

- **Selectors 4 through 6: Detection of international tone**

Upon detection of the 2nd dial tone for the time length specified by these selectors, the equipment starts dialing.

This setting is effective only when the 2nd dial tone detection function is activated by selectors 1 through 3 (Setting 1 0 1, 1 1 0, or 1 1 1).

This function does not apply in those countries where no dial tone detection function is supported.

- **Selector 7: No. of 2nd dial tone detection times**

This selector sets the number of dial tone detection times required for starting dialing.

- **Selector 8: 2nd dial tone interrupt detecting time**

This selector sets the allowable time length of an interrupt which should not be interpreted as an interrupt in the 2nd tone dialing.

WSW07 (Dial tone setting 1)

Selector No.	Function	Setting and Specifications
1 2	Frequency band range	No. 1 2 0 0 : Narrows by 10 Hz 0 1 : Initial value 1 X : Widens by 10 Hz
3	Line current detection	0: No 1: Yes
4 6	2nd dial tone detection level (Z = 600 Ω)	No. 4 5 6 0 0 0 : -21 dBm 0 0 1 : -24 dBm 0 1 0 : -27 dBm 0 1 1 : -30 dBm 1 0 0 : -33 dBm 1 0 1 : -36 dBm 1 1 0 : -39 dBm 1 1 1 : -42 dBm
7	1st dial tone interrupt detecting time	0: 30 ms 1: 50 ms
8	PABX loop current control	0: Disabled 1: Enabled

NOTE: The WSW07 is not applicable in those countries where no dial tone or line current detection is supported, e.g., U.S.A.

- **Selectors 1 and 2: Frequency band range**

These selectors set the frequency band for the 1st dial tone and the busy tone (before dialing) to be detected.

This setting is effective only when selectors 1 through 3 of WSW05 are set to "1,1,1."

- **Selector 3: Line current detection**

This selector determines whether or not the equipment should detect a line current before starting dialing.

- **Selectors 4 through 6: 2nd dial tone detection level**

These selectors set the detection level of the 2nd dial tone.

- **Selector 7: 1st dial tone interrupt detecting time**

This selector sets the allowable time length of an interrupt which should not be interpreted as an interrupt in the 1st dial tone dialing.

- **Selector 8: PABX loop current control**

This selector determines whether the PABX loop current control will be enabled or disabled. Setting this selector to "1" enables the loop current control that automatically switches the internal resistance inserted in series with the communications line on and off depending upon the loop current amount. Setting this selector to "0" disables the loop current control and keeps the internal resistance on.

For some PABXs that are not compatible with the facsimile equipment in voltage rating, set this selector to "0."

The setting made by this selector takes effect only when the user selects the PABX. If no PABX is selected, the PABX loop current control will be enabled independent of this setting.

WSW08 (Dial tone setting 2)

Selector No.	Function	Setting and Specifications
1 3	1st dial tone detection time length	No. 1 2 3 0 0 0 : 50 ms 0 0 1 : 210 ms 0 1 0 : 500 ms 0 1 1 : 800 ms 1 0 0 : 900 ms 1 0 1 : 1.5 sec. 1 1 0 : 2.0 sec. 1 1 1 : 2.5 sec.
4 5	Time-out length for 1st and 2nd dial tone detection	No. 4 5 0 0 : 10 sec. 0 1 : 20 sec. 1 0 : 15 sec. 1 1 : 30 sec.
6 8	Detection level of 1st dial tone and busy tone before dialing	No. 6 7 8 0 0 0 : -21 dBm 0 0 1 : -24 dBm 0 1 0 : -27 dBm 0 1 1 : -30 dBm 1 0 0 : -33 dBm 1 0 1 : -36 dBm 1 1 0 : -39 dBm 1 1 1 : -42 dBm

NOTE: The WSW08 is not applicable in those countries where no dial tone detection is supported, e.g., U.S.A.

● **Selectors 1 through 3: 1st dial tone detection time length**

Upon detection of the 1st dial tone for the time length set by these selectors, the equipment starts dialing.

This setting is effective only when selectors 1 through 3 of WSW05 are set to "1,1,1."

● **Selectors 4 and 5: Time-out length for 1st and 2nd dial tone detection**

These selectors set the time-out length for the 1st and 2nd dial tone detection so that the equipment waits dial tone input for the specified time length and disconnects itself from the line when no dial tone is inputted.

WSW09 (Protocol definition 1)

Selector No.	Function	Setting and Specifications
1	Frame length selection	0: 256 octets 1: 64 octets
2	Use of non-standard commands	0: Allowed 1: Prohibited
3	No. of retries	No. 3 4
4		0 0 : 4 times
		0 1 : 3 times
		1 0 : 2 times
		1 1 : 1 time
5	T5 timer	0: 300 sec. 1: 60 sec.
6	T1 timer	0: 35 sec. 1: 40 sec.
7	Elapsed time for time-out control for no response from the called station in automatic sending mode	No. 7 8
8		0 0 : 60 sec.
		0 1 : 140 sec. (in the French versions) 70 sec. (in other versions)
		1 0 : 90 sec.
		1 1 : 35 sec.

NOTE: Selectors 1 through 5 are not applicable in those models which do not support ECM.

- **Selector 1: Frame length selection**

Usually a single frame consists of 256 octets (1 octet = 8 bits). For communications lines with higher bit error rate, however, set selector 1 to "1" so that the facsimile equipment can divide a message into 64-octet frames.

Remarks: The error correction mode (ECM) is a facsimile transmission manner in which the equipment divides a message into frames for transmission so that if any data error occurs on the transmission line, the equipment retransmits only those frames containing the error data.

- **Selector 2: Use of non-standard commands**

If this selector is set to "0," the equipment may use non-standard commands (the machine's native-mode commands, e.g., NSF, NSC, and NSS) for communications. If it is set to "1," the equipment will use standard commands only.

- **Selectors 3 and 4: No. of retries**

These selectors set the number of retries in each specified modem transmission speed.

- **Selector 5: T5 timer**

This selector sets the time length for the T5 timer.

- **Selector 6: T1 timer**

This selector sets the time length for the T1 timer.

- **Selectors 7 and 8: Elapsed time for time-out control**

If the equipment receives no response (no G3 command) from the called terminal in automatic sending during the time set by these selectors, it disconnects the line.

WSW10 (Protocol definition 2)

Selector No.	Function	Setting and Specifications
1	Switching of DPS, following the CML ON/OFF	0: No 1: Yes
2	Time length from transmission of the last dial digit to CML ON	0: 100 ms 1: 50 ms
3	Time length from CML ON to CNG transmission	0: 2 sec. 1: 4 sec.
4	Time length from CML ON to CED transmission (except for facsimile-to-telephone switching)	0: 0.5 sec. 1: 2 sec.
5 6	No. of training retries	No. 5 6 0 0 : 1 time 0 1 : 2 times 1 0 : 3 times 1 1 : 4 times
7 8	Not used.	

- **Selector 1: Switching of DPS, following the CML ON/OFF**
Setting this selector to "1" automatically switches DPS following the CML ON/OFF operation.
- **Selector 2: Time length from transmission of the last dial digit to CML ON**
This selector sets the time length from when the equipment transmits the last dial digit until the CML relay comes on.
- **Selector 3: Time length from CML ON to CNG transmission**
This selector sets the time length until the equipment transmits a CNG after it turns on the CML relay.
- **Selector 4: Time length from CML ON to CED transmission**
This selector sets the time length until the equipment transmits a CED after it turns on the CML relay. This setting does not apply to switching between facsimile and telephone.
- **Selectors 5 and 6: No. of training retries**
These selectors set the number of training retries to be repeated before automatic fallback.

WSW11 (Busy tone setting)

Selector No.	Function	Setting and Specifications
1 2	Frequency band range	No. 1 2 0 0 : Narrows by 10 Hz 0 1 : Initial value 1 x : Widens by 10 Hz
3	Not used.	
4	ON/OFF time length ranges (More than one setting allowed)	1: 400-600/400-600 ms
5		1: 175-440/175-440 ms
6		1: 100-1000/17-660 ms
7		1: 110-410/320-550 ms
8		1: 100-660/100-660 ms

NOTE: WSW11 is not applicable in those countries where no busy tone detection is supported.

NOTE: The setting of WSW11 is effective only when selectors 5 and 6 of WSW05 are set to "0, 1" or "1, 1" (Busy tone detection).

- **Selectors 1 and 2: Frequency band range**

These selectors set the frequency band for busy tone to be detected.

- **Selectors 4 through 8: ON/OFF time length ranges**

These selectors set the ON and OFF time length ranges for busy tone to be detected. If more than one selector is set to "1," the ranges become wider. For example, if selectors 4 and 5 are set to "1," the ON and OFF time length ranges are from 175 to 600 ms.

WSW12 (Signal detection condition setting)

Selector No.	Function	Setting and Specifications
1 2	Min. OFF time length of calling signal (Ci)	No. 1 2 0 0 : 1500 ms 0 1 : 500 ms 1 0 : 700 ms 1 1 : 900 ms
3 4	Max. OFF time length of calling signal (Ci)	No. 3 4 0 0 : 6 sec. 0 1 : 7 sec. 1 0 : 9 sec. 1 1 : 11 sec.
5 6	Detecting time setting	No. 5 6 0 0 : 800 ms (1000 ms*) 0 1 : 200 ms 1 0 : 250 ms 1 1 : 150 ms
7	Delay	0: Yes 1: No
8	Not used.	

* 1000 ms in Chinese versions.

● **Selectors 1 through 4: Min. and max. OFF time length of calling signal (Ci)**

If the equipment detects the OFF state of calling signal (Ci) for a time length which is greater than the value set by selectors 1 and 2 and less than the value set by selectors 3 and 4, it interprets the Ci signal as OFF.

● **Selectors 5 and 6: Detecting time setting**

These selectors set the time length required to make the equipment acknowledge itself to be called. That is, if the equipment continuously detects calling signals with the frequency set by selectors 1 through 4 of WSW14 during the time length set by these selectors 5 and 6, it acknowledges the call.

● **Selector 7: Delay**

Setting this selector to "0" allows the equipment to insert a 900 ms WAIT after acknowledgment of the call until the equipment turns on the CML relay to start receiving operation.

WSW13 (Modem setting)

Selector No.	Function	Setting and Specifications
1 2	Cable equalizer	No. 1 2 0 0 : 0 km 0 1 : 1.8 km 1 0 : 3.6 km 1 1 : 5.6 km
3 4	Reception level	No. 3 4 0 0 : -43 dBm 0 1 : -47 dBm 1 0 : -49 dBm 1 1 : -51 dBm
5 8	Modem attenuator	0: 0 dB 1: 8 dB 0: 0 dB 1: 4 dB 0: 0 dB 1: 2 dB 0: 0 dB 1: 1 dB

The modem should be adjusted according to the user's line conditions.

- **Selectors 1 and 2: Cable equalizer**

These selectors are used to improve the pass-band characteristics of analogue signals on a line. (Attenuation in the high-band frequency is greater than in the low-band frequency.)

Set these selectors according to the distance from the telephone switchboard to the facsimile equipment.

- **Selectors 3 and 4: Reception level**

These selectors set the optimum receive signal level.

- **Selectors 5 through 8: Modem attenuator**

These selectors are used to adjust the transmitting level of the modem when the reception level at the remote station is improper due to line loss. This function applies for G3 protocol signals.

Setting two or more selectors to "1" produces addition of attenuation assigned to each selector.

This setting will be limited if selector 8 of WSW23 is set to "0."

WSW14 (AUTO ANS facility setting)

Selector No.	Function	Setting and Specifications
1 2	Frequency band selection (Lower limit)	No. 1 2 0 0 : 13 Hz 0 1 : 15 Hz 1 0 : 23 Hz 1 1 : 20 Hz
3 4	Frequency band selection (Upper limit)	No. 3 4 0 0 : 30 Hz 0 1 : 55 Hz 1 X : 70 Hz
5 8	No. of rings in AUTO ANS mode	No. 5 6 7 8 0 0 0 0 : Fixed to once 0 0 0 1 : Fixed to 2 times 0 0 1 0 : Fixed to 3 times 0 0 1 1 : Fixed to 4 times 0 1 0 0 : 1 to 2 times 0 1 0 1 : 1 to 3 times 0 1 1 0 : 1 to 4 times 0 1 1 1 : 1 to 5 times 1 0 0 0 : 2 to 3 times 1 0 0 1 : 2 to 4 times 1 0 1 0 : 2 to 5 times 1 0 1 1 : 2 to 6 times 1 1 0 0 : 1 to 10 times 1 1 0 1 : 2 to 10 times 1 1 1 0 : 3 to 5 times 1 1 1 1 : 4 to 10 times

● **Selectors 1 through 4: Frequency band selection**

These selectors are used to select the frequency band of calling signals for activating the AUTO ANS facility.

In the French versions, if the user sets the PBX to OFF from the control panel, the setting made by selectors 1 and 2 will take no effect and the frequency's lower limit will be fixed to 32 Hz. (Even if the setting made by these selectors does not apply, it will be printed on the configuration list.)

● **Selectors 5 through 8: No. of rings in AUTO ANS mode**

These selectors set the number of rings to initiate the AUTO ANS facility.

WSW15 (REDIAL facility setting)

Selector No.	Function	Setting and Specifications
1 2	Selection of redial interval	No. 1 2 0 0 : 5 minutes 0 1 : 1 minute 1 0 : 2 minutes 1 1 : 3 minutes
3 6	No. of redialings	No. 3 4 5 6 0 0 0 0 : 16 times 0 0 0 1 : 1 times 0 0 1 0 : 2 times 0 0 1 1 : 3 times 1 1 1 1 : 15 times
7	Redialing for no response sent from the called terminal	0: Redialing 1: No redialing
8	Not used.	

- **Selectors 1 through 6: Selection of redial interval and No. of redialings**

The equipment redials by the number of times set by selectors 3 through 6 at intervals set by selectors 1 and 2.

- **Selectors 7: Redialing for no response sent from the called terminal**

This selector determines whether or not the equipment redials if no G3 command response comes from the called station after dialing within the time length set by selectors 7 and 8 of WSW09.

WSW16 (Function setting 1)

Selector No.	Function	Setting and Specifications	
1	Automatic cutter	0: ON	1: OFF
2	CCITT superfine recommendation	0: OFF	1: ON
3 6	Not used.		
7	Max. document length limitation	0: 400 cm	1: 90 cm
8	Stop key pressed during reception	0: Not functional	1: Functional

- **Selector 1: Automatic cutter**

This selector activates or deactivates the automatic cutter.

- **Selector 2: CCITT superfine recommendation**

If this selector is set to "1," the equipment communicates in CCITT recommended superfine mode (15.4 lines/mm). If it is set to "0," it communicates in native superfine mode.

- **Selector 7: Max. document length limitation**

This selector is used to select the maximum length of a document to be sent.

- **Selector 8: Stop key pressed during reception**

If this selector is set to "1," pressing the **Stop** key can stop the current receiving operation. The received data will be lost.

WSW17 (Function setting 2)

Selector No.	Function	Setting and Specifications												
1 2	Off-hook alarm	<table border="0"> <tr> <td>No. 1</td> <td>2</td> <td></td> </tr> <tr> <td>0</td> <td>0</td> <td>: No alarm</td> </tr> <tr> <td>0</td> <td>1</td> <td>: Always valid</td> </tr> <tr> <td>1</td> <td>X</td> <td>: Valid except when 'call reservation' is selected.</td> </tr> </table>	No. 1	2		0	0	: No alarm	0	1	: Always valid	1	X	: Valid except when 'call reservation' is selected.
No. 1	2													
0	0	: No alarm												
0	1	: Always valid												
1	X	: Valid except when 'call reservation' is selected.												
3	Power failure report output	0: ON 1: OFF												
4	Calendar clock/prompt alternate display	0: No 1: Yes												
5	Calendar clock type	0: U.S.A. type 1: European type												
6	Error indication in activity report	0: No 1: Yes												
7	Non-ring reception	0: OFF 1: ON												
8	Not used.													

NOTE: Selector 3 is not applicable to the U.S.A. versions.

- **Selectors 1 and 2: Off-hook alarm**

These selectors activate or deactivate the alarm function which sounds an alarm when the communication is completed with the handset being off the hook.

- **Selector 3: Power failure report output**

This selector determines whether or not the equipment outputs a power failure report when the power comes back on.

- **Selector 4: Calendar clock/prompt alternate display**

If this selector is set to "1," the calendar clock and the prompt "INSERT DOCUMENT" appear alternately on the LCD while the equipment is on standby; if it is set to "0," only the calendar clock appears.

- **Selector 5: Calendar clock type**

If this selector is set to "0" (USA), the MM/DD/YY hh:mm format applies; if it is set to "1" (Europe), the DD/MM/YY hh:mm format applies: DD is the day, MM is the month, YY is the last two digits of the year, hh is the hour, and mm is the minute.

- **Selector 6: Error indication in activity report**

This selector determines whether or not a communications error code will be printed in the activity report.

- **Selector 7: Non-ring reception**

Setting this selector to "1" makes the equipment receive calls without ringer sound if the ring delay is set to 0.

WSW18 (Function setting 3)

Selector No.	Function	Setting and Specifications
1	Not used.	
2 3	Detection enabled time for CNG and no tone	No. 2 3 0 0 : 40 sec. 0 1 : 0 sec. (No detection) 1 0 : 5 sec. 1 1 : 80 sec.
4	ACS* check sheet output function on/off key	0: Operative 1: Inoperative
5	ACS* check sheet output function	0: ON 1: OFF
6	Registration of station ID	0: Permitted 1: Prohibited
7 8	Tone sound monitoring	No. 7 8 0 X : No monitoring 1 0 : Up to phase B at the calling station only 1 1 : All transmission phases both at the calling and called stations

*ACS: Anti-curl system

- **Selectors 2 and 3: Detection enabled time for CNG and no tone**

After the line is connected via the external telephone or by picking up the handset of the facsimile equipment, the equipment can detect a CNG signal or no tone for the time length specified by these selectors. The setting specified by these selectors becomes effective only when selector 8 of WSW20 is set to "1."

- **Selector 4: ACS check sheet output function on/off key**

If this selector is set to "0" (Operative), the user can toggle the ACS check sheet output function on and off by pressing one-touch keys **01** and **05** simultaneously. If it is set to "1" (Inoperative), the user cannot toggle the ACS check sheet output function from the control panel so that the setting specified by selector 5 takes effect.

- **Selector 5: ACS check sheet output function**

When selector 4 is set to "0," the setting specified by this selector becomes the default state of the ACS check sheet output function. When selector 4 is set to "1," the setting specified by this selector permanently takes effect.

- **Selector 6: Registration of station ID**

Setting this selector to "0" permits the registration of station ID for Austrian and Czech versions.

- **Selectors 7 and 8: Tone sound monitoring**

These selectors set monitoring specifications of the tone sound inputted from the line.

WSW19 (Transmission speed setting)

Selector No.	Function	Setting and Specifications
1 3	First transmission speed choice for fallback	No. 1 2 3 No. 4 5 6 0 0 0 : 2,400 bps 0 0 1 : 4,800 bps 0 1 0 : 7,200 bps 0 1 1 : 9,600 bps 1 0 0 : 12,000 bps * 1 0 1 : } 14,400 bps * 1 1 0 : 1 1 1 :
4 6	Last transmission speed choice for fallback	
7	Not used.	
8	V. 17 mode	0: Permitted 1: Prohibited

- In those models with a maximum of 9600 bps capability, selection of 12,000 bps or 14,400 bps will still only produce a set speed automatically reduced to 9600 bps.

NOTE: Selector 8 is applicable only to those models that support 14,400 bps.

• **Selectors 1 through 6: First and last choices of transmission speed for fallback**

These selectors are used to set the MODEM speed range. With the first transmission speed choice specified by selectors 1 through 3, the equipment attempts to synchronize the data transmission via the MODEM. If the synchronization fails, the equipment automatically steps down to the next lowest speed and attempts to synchronize the data transmission again. The equipment repeats this sequence while stepping down the transmission speed to the last choice specified by selectors 4 through 6.

If the MODEM always falls back to a low transmission speed (e.g., 4,800 bps), set the first transmission speed choice to the lower one (e.g., modify it from 12,000 bps to 7,200 bps) in order to deactivate the high-speed MODEM function and reduce the training time for shorter transmission time.

Generally, to save the transmission time, set the last transmission speed choice to a higher one.

WSW20 (Overseas communications mode setting)

Selector No.	Function	Setting and Specifications
1	EP* tone prefix	0: OFF 1: ON
2	Overseas communications mode (Reception)	0: 2100 Hz 1: 1100 Hz
3	Overseas communications mode (Transmission)	0: OFF 1: Ignores DIS once.
4 5	Min. time length from reception of CFR to start of transmission of video signals	No. 4 5 0 0 : 100 ms 0 1 : 200 ms 1 0 : 300 ms 1 1 : 400 ms
6 7	Chattering elimination for CNG detection	No. 6 7 0 0 : A (During CNG ON and OFF) 0 1 : B (During CNG OFF only) 1 X : C (No elimination)
8	CNG detection on/off	0: OFF 1: ON

* EP: Echo protection

● **Selector 1: EP tone prefix**

Setting this selector to "1" makes the equipment transmit a 1700 Hz echo protection (EP) tone immediately preceding training in V.29 modulation system to prevent omission of training signals.

Prefixing an EP tone is effective when the equipment fails to transmit at the V.29 modem speed and always has to fall back to 4800 bps transmission.

● **Selectors 2 and 3: Overseas communications mode**

These selectors should be used if the facsimile equipment malfunctions in overseas communications. According to the communications error state, select the signal specifications.

Setting selector 2 to "1" allows the equipment to use 1100 Hz CED signal instead of 2100 Hz in receiving operation. This prevents malfunctions resulting from echoes, since the 1100 Hz signal does not disable the echo suppressor (ES) while the 2100 Hz signal does.

Setting selector 3 to "1" allows the equipment to ignore a DIS signal sent from the called station once in sending operation. This operation suppresses echoes since the first DIS signal immediately follows a 2100 Hz CED (which disables the ES) so that it is likely to be affected by echoes in the disabled ES state. However, such a disabled ES state will be removed soon so that the second and the following DIS signals are not susceptible to data distortion due to echoes. Note that some models when called may cause error by receiving a self-outputted DIS.

● **Selectors 8: CNG detection on/off**

If this selector is set to "1," the equipment detects a CNG signal according to the condition preset by selectors 2 and 3 of WSW18 after a line is connected. If it is set to "0," the equipment detects a CNG signal as long as the line is connected.

WSW21 (TAD setting 1)

Selector No.	Function	Setting and Specifications
1 5	Max. waiting time for voice signal	No. 1 2 3 4 5 0 0 0 0 0 : No detection 0 0 0 0 1 : 1 sec. 0 0 0 1 0 : 2 sec. 0 0 0 1 1 : 3 sec. 0 1 0 0 0 : 8 sec. 1 1 1 1 1 : 31 sec.
6 7	Two-way recording	No. 6 7 0 0 : For U.S.A. (A) 0 1 : Except for U.S.A. (B) 1 0 : Without beep (C) 1 1 : OFF (D)
8	Erasure of message stored in the memory after the message transfer	0: Yes 1: No

NOTE: Selectors 1 through 8 are applicable to those models equipped with a built-in TAD.

- **Selectors 1 through 5: Max. waiting time for voice signal**

In the TAD mode, the equipment waits for voice signal for the time length specified by these selectors before it automatically shifts to the facsimile message receive mode or disconnects the line.

- **Selectors 6 and 7: Two-way recording**

These selectors select the specifications of the two-way recording feature.

- **Selector 8: Erasure of message**

Setting this selector to "0" will erase the message recorded in the memory after the document retrieval feature transfers the message.

WSW22 (ECM)

Selector No.	Function	Setting and Specifications	
1	ECM* in sending	0: ON	1: OFF
2	ECM* in receiving	0: ON	1: OFF
3 4	Not used.		
5 8	Acceptable TCF bit error rate (%) (Only at 4800 bps)	0: 0%	1: 8%
		0: 0%	1: 4%
		0: 0%	1: 2%
		0: 0%	1: 1%

* ECM: Error correction mode

NOTE: Selectors 5 through 8 are applicable to the Chinese, Taiwanese and Asian versions only.

● **Selectors 5 through 8: Acceptable TCF bit error rate (%)**

Setting two or more selectors to "1" produces addition of percent assigned to each selector. If you set selectors 7 and 8 to "1," the acceptable TCF bit error rate will be 3%.

WSW23 (Communications setting)

Selector No.	Function	Setting and Specifications
1	Starting point of training check (TCF)	0: From the head of a series of zeros 1: From any arbitrary point
2 3	Allowable training error rate	No. 2 3 0 0 : 0% 0 1 : 0.5% 1 0 : 1% 1 1 : 2%
4 5		No. 4 5 0 0 : 16% 0 1 : 14% 1 0 : 10% 1 1 : 8%
6 7	Not used.	
8	Limitation of attenuation level	0: Yes 1: No

NOTE: Selector 8 is not applicable to the French and Chinese versions.

- **Selector 1: Starting point of training check (TCF)**

At the training phase of receiving operation, the called station detects for 1.0 second a training check (TCF) command, a series of zeros which is sent from the calling station for 1.5 seconds to verify training and give the first indication of the acceptability of the line.

This selector sets the starting point from which the called station should start counting those zeros. If this selector is set to "0," the called station starts counting zeros 100 ms after the head of a series of zeros is detected.

If it is set to "1," the called station starts counting zeros upon detection of 10-ms successive zeros 50 ms after the head of a series of zeros is detected. In this case, if the detection of 10-ms successive zeros is too late, the data counting period will become less than 1.0 second, making the called station judge the line condition unacceptable.

- **Selectors 2 and 3: Allowable training error rate**

The called station checks a series of zeros gathered in training (as described in Selector 1) according to the allowable training error rate set by these selectors. If the called station judges the line condition to be accepted, it responds with CFR; if not, it responds with FTT.

- **Selectors 4 and 5: Decoding error rate for transmission of RTN**

The facsimile equipment checks the actual decoding errors and then transmits an RTN according to the decoding error rate (Number of lines containing an error per page ÷ Total number of lines per page) set by these selectors.

- **Selector 8: Limitation of attenuation level**

Setting this selector to "0" limits the transmitting level of the modem to 10 dB.

This setting has priority over the settings selected by WSW02 (selectors 5 through 8) and WSW13 (selectors 5 through 8).

WSW24 (TAD setting 2)

Selector No.	Function	Setting and Specifications
1 2	Maximum OGM recording time	No. 1 2 0 0 : 15 sec. 0 1 : 20 sec. 1 0 : 30 sec. 1 1 : 50 sec.
3 4	Time length from CML ON to start of pseudo ring backtone transmission	No. 3 4 0 0 : 4 sec. 0 1 : 3 sec. 1 0 : 2 sec. 1 1 : 1 sec.
5 8	Attenuator for playback of ICM/OGM to the line (Selectable from the range of 0-15 dB)	0: 0 dB 1: 8 dB 0: 0 dB 1: 4 dB 0: 0 dB 1: 2 dB 0: 0 dB 1: 1 dB

NOTE: Selectors 1 and 2 are applicable to those models equipped with a built-in TAD.

- **Selectors 1 and 2: Maximum OGM recording time**

These selectors set the allowable maximum recording time for an OGM.

- **Selectors 3 and 4: Time length from CML ON to start of pseudo ring backtone transmission**

These selectors set the length of time from CML-ON up to the start of pseudo ring backtone transmission.

In those versions which have an OGM facility, the settings made by these selectors also apply to the length of time from CML-ON up to the start of OGM transmission.

- **Selectors 5 through 8: Attenuator for playback of ICM/OGM to the line**

Setting two or more selectors to "1" produces addition of attenuation assigned to each selector.

This setting will not be limited by selector 8 of WSW23.

WSW25 (TAD setting 3)

Selector No.	Function	Setting and Specifications																																																						
1 4	Not used.																																																							
5 7	Pause between paging number and PIN	<table> <tr> <td>No.</td> <td>5</td> <td>6</td> <td>7</td> <td></td> <td></td> </tr> <tr> <td></td> <td>0</td> <td>0</td> <td>0</td> <td>:</td> <td>2 sec.</td> </tr> <tr> <td></td> <td>0</td> <td>0</td> <td>1</td> <td>:</td> <td>4 sec.</td> </tr> <tr> <td></td> <td>0</td> <td>1</td> <td>0</td> <td>:</td> <td>6 sec.</td> </tr> <tr> <td></td> <td>0</td> <td>1</td> <td>1</td> <td>:</td> <td>8 sec.</td> </tr> <tr> <td></td> <td>1</td> <td>0</td> <td>0</td> <td>:</td> <td>10 sec.</td> </tr> <tr> <td></td> <td>1</td> <td>0</td> <td>1</td> <td>:</td> <td>12 sec.</td> </tr> <tr> <td></td> <td>1</td> <td>1</td> <td>0</td> <td>:</td> <td>14 sec.</td> </tr> <tr> <td></td> <td>1</td> <td>1</td> <td>1</td> <td>:</td> <td>16 sec.</td> </tr> </table>	No.	5	6	7				0	0	0	:	2 sec.		0	0	1	:	4 sec.		0	1	0	:	6 sec.		0	1	1	:	8 sec.		1	0	0	:	10 sec.		1	0	1	:	12 sec.		1	1	0	:	14 sec.		1	1	1	:	16 sec.
No.	5	6	7																																																					
	0	0	0	:	2 sec.																																																			
	0	0	1	:	4 sec.																																																			
	0	1	0	:	6 sec.																																																			
	0	1	1	:	8 sec.																																																			
	1	0	0	:	10 sec.																																																			
	1	0	1	:	12 sec.																																																			
	1	1	0	:	14 sec.																																																			
	1	1	1	:	16 sec.																																																			
8	Not used.																																																							

NOTE: Selectors 5 through 7 are applicable to the U.S.A. and Canadian versions of the FAX355MC/FAX375MC.

- **Selectors 5 through 7: Pause between paging number and PIN**

These selectors set the pause time between a telephone number being paged and PIN (private identification number) for the paging feature.

WSW26 (Function setting 4)

Selector No.	Function	Setting and Specifications
1	Application of DC wetting pulse	0: OFF 1: ON
2	Overvoltage limiter at the applying time of a wetting pulse	0: ON 1: OFF
3	Not used.	
4	No. of CNG cycles to be detected (when the line is connected via the external telephone except in the external TAD mode)	No. 4 5
5		0 0 : 0.5 (A)
		0 1 : 1 (B)
		1 0 : 1.5 (C)
		1 1 : 2 (D)
6	No. of CNG cycles to be detected (when the line is connected via the external telephone in the external TAD mode or via the facsimile equipment in F/T mode)	No. 6 7
7		0 0 : 0.5 (A)
		0 1 : 1 (B)
		1 0 : 1.5 (C)
		1 1 : 2 (D)
8	FAX reception after the time-out of pseudo ring backtones in F/T mode	0: Yes 1: No

NOTE: Selectors 1 and 2 are not applicable to the German versions.

NOTE: Selectors 6 and 7 are not applicable to those models equipped with a built-in TAD.

● **Selectors 1 and 2: Application of DC wetting pulse and overvoltage limiter**

These selectors take effect only when the UK version of the facsimile equipment is set up for the British Telecom's caller ID service or its equivalent.

Selector 2 takes effect only when selector 1 is set to "1."

● **Selectors 4 and 5: No. of CNG cycles to be detected**

The equipment interprets a CNG as an effective signal if it detects a CNG signal by the number of cycles specified by these selectors when the line is connected via the external telephone except in the external TAD mode.

● **Selectors 6 and 7: No. of CNG cycles to be detected**

The equipment interprets a CNG as an effective signal if it detects a CNG signal by the number of cycles specified by these selectors when the line is connected via the external telephone in the external TAD mode or via the facsimile equipment in F/T mode.

● **Selector 8: FAX reception after the time-out of pseudo ring backtones in F/T mode**

If this selector is set to "0," the equipment starts receiving FAX messages when it receives a CNG signal within 10-second no-tone period provided after the time-out of pseudo ring backtones. If no CNG is received within the period, the equipment disconnects the line.

If this selector is set to "1," the equipment disconnects the line after issuing pseudo ring backtones.

WSW27 (Function setting 5)

Selector No.	Function	Setting and Specifications
1	Definition of programmable key	0: TEL key 1: TEL/POLLING key
2	Ringer OFF setting	0: Yes 1: No
3	Automatic playback of OGM at the start time of OGM ON mode	0: No 1: Yes
4	Detection of distinctive ringing pattern	0: Yes 1: No
5 7	Not used.	
8	Motor overheating error indication	0: No 1: Yes

NOTE: Selector 1 is not applicable to the U.S.A. versions.

NOTE: Selectors 3 and 6 are applicable to those models equipped with a built-in TAD.

- **Selector 1: Definition of programmable key**

This selector defines a programmable key as a TEL key or TEL/POLLING key.

Setting this selector to "1" allows the programmable key to function as either a TEL or POLLING key if pressed when the handset is off or on the hook, respectively.

This setting is effective only for those models having a programmable key.

- **Selector 2: Ringer OFF setting**

This selector determines whether or not the ringer can be set to OFF.

- **Selector 3: Automatic playback of OGM at the start time of OGM ON mode**

This selector determines whether or not the equipment automatically plays back an OGM the moment it switches to the OGM ON mode in the MC mode.

- **Selector 4: Detection of distinctive ringing pattern**

If this selector is set to "1," the equipment detects only the number of rings; if it is set to "0," the equipment detects the number of rings and the ringing time length to compare the detected ringing pattern with the registered distinctive one.

- **Selector 8: Motor overheating error indication**

If this selector is set to "0," the equipment displays the message "PRINTER FAULT" on the LCD whenever a motor overheating error occurs so that any of the following happens and the equipment aborts recording:

- The number of printed documents is five or less although the receiving operation continues for 15 minutes or more.
- The number of printed documents is 10 or less although the receiving operation continues for 20 minutes or more.

WSW28 (Function setting 6)

Selector No.	Function	Setting and Specifications
1 3	Transmission level of DTMF high-band frequency signal	No. 1 2 3 0 0 0 : 0 dB 0 0 1 : +1 dB 0 1 0 : +2 dB 0 1 1 : +3 dB 1 0 0 : 0 dB 1 0 1 : -1 dB 1 1 0 : -2 dB 1 1 1 : -3 dB
4 6	Transmission level of DTMF low-band frequency signal	No. 4 5 6 0 0 0 : 0 dB 0 0 1 : +1 dB 0 1 0 : +2 dB 0 1 1 : +3 dB 1 0 0 : 0 dB 1 0 1 : -1 dB 1 1 0 : -2 dB 1 1 1 : -3 dB
7 8	Not used.	

• **Selectors 1 through 6: Transmission level of DTMF high-/low-band frequency signal**

These selectors are intended for the manufacturer who tests the equipment for the Standard. Never access them.

WSW29 (Function setting 7)

Selector No.	Function	Setting and Specifications
1 3	Compression threshold level for voice signals inputted via the telephone line in the built-in TAD operation	No. 1 2 3 0 0 0 : -47.0 dBm (A) 0 0 1 : -48.5 dBm (B) 0 1 0 : -50.0 dBm (C) 0 1 1 : -51.5 dBm (D) 1 0 0 : -53.0 dBm (E) 1 0 1 : -54.5 dBm (F) 1 1 0 : -56.0 dBm (G) 1 1 1 : OFF (H)
4 6	Compression threshold level for voice signals inputted via the handset in the built-in TAD operation	No. 4 5 6 0 0 0 : -44.0 dBm (A) 0 0 1 : -45.5 dBm (B) 0 1 0 : -47.0 dBm (C) 0 1 1 : -48.5 dBm (D) 1 0 0 : -50.0 dBm (E) 1 0 1 : -51.5 dBm (F) 1 1 0 : -53.0 dBm (G) 1 1 1 : OFF (H)
7	Not used.	
8	Prompt beep for activity report	0: No 1: Yes

NOTE: Selectors 1 through 6 are applicable to those models equipped with a built-in TAD.

NOTE: Selector 8 is not applicable to the U.S.A. versions.

- **Selectors 1 through 6: Compression threshold level for voice signals inputted via the telephone line in the built-in TAD operation**

If voice signals inputted via the telephone line are below the level specified by these selectors, the TAD interprets those received voice signals as no signal, compressing the recording time.

- **Selector 8: Prompt beep for activity report**

This selector determines whether or not the equipment will beep if the activity report memory area becomes full with 30 records, for prompting you to print out the report. (Printing it out will clear the memory area.)

WSW30 (Function setting 8)

Selector No.	Function	Setting and Specifications																																																						
1 3	Detection level of dial tone or busy tone for the built-in TAD operation	<table border="0"> <tr> <td>No.</td> <td>1</td> <td>2</td> <td>3</td> <td></td> <td></td> </tr> <tr> <td></td> <td>0</td> <td>0</td> <td>0</td> <td>:</td> <td>-38.0 dBm (A)</td> </tr> <tr> <td></td> <td>0</td> <td>0</td> <td>1</td> <td>:</td> <td>-39.5 dBm (B)</td> </tr> <tr> <td></td> <td>0</td> <td>1</td> <td>0</td> <td>:</td> <td>-41.0 dBm (C)</td> </tr> <tr> <td></td> <td>0</td> <td>1</td> <td>1</td> <td>:</td> <td>-42.5 dBm (D)</td> </tr> <tr> <td></td> <td>1</td> <td>0</td> <td>0</td> <td>:</td> <td>-44.0 dBm (E)</td> </tr> <tr> <td></td> <td>1</td> <td>0</td> <td>1</td> <td>:</td> <td>-45.5 dBm (F)</td> </tr> <tr> <td></td> <td>1</td> <td>1</td> <td>0</td> <td>:</td> <td>-47.0 dBm (G)</td> </tr> <tr> <td></td> <td>1</td> <td>1</td> <td>1</td> <td>:</td> <td>-48.5 dBm (H)</td> </tr> </table>	No.	1	2	3				0	0	0	:	-38.0 dBm (A)		0	0	1	:	-39.5 dBm (B)		0	1	0	:	-41.0 dBm (C)		0	1	1	:	-42.5 dBm (D)		1	0	0	:	-44.0 dBm (E)		1	0	1	:	-45.5 dBm (F)		1	1	0	:	-47.0 dBm (G)		1	1	1	:	-48.5 dBm (H)
No.	1	2	3																																																					
	0	0	0	:	-38.0 dBm (A)																																																			
	0	0	1	:	-39.5 dBm (B)																																																			
	0	1	0	:	-41.0 dBm (C)																																																			
	0	1	1	:	-42.5 dBm (D)																																																			
	1	0	0	:	-44.0 dBm (E)																																																			
	1	0	1	:	-45.5 dBm (F)																																																			
	1	1	0	:	-47.0 dBm (G)																																																			
	1	1	1	:	-48.5 dBm (H)																																																			
4 8	Not used.																																																							

NOTE: Selectors 1 through 3 are applicable to those models equipped with a built-in TAD.

- **Selectors 1 through 3: Detection level of dial tone or busy tone for built-in TAD operation**

If dial tone or busy tone inputted during ICM recording is below the level specified by these selectors, the TAD stops recording and disconnects the line.

WSW31 (Function setting 9)

Selector No.	Function	Setting and Specifications
1 4	Not used.	
5	Minimum short-OFF duration in distinctive ringing	0: 130 ms 1: 90 ms
6 8	Not used.	

NOTE: Selector 5 is applicable in those areas where the distinctive ringing is supported.

- **Selector 5 Minimum short-OFF duration in distinctive ringing**

The ringer pattern consists of short and long rings, e.g., short-short-long rings. This selector sets the minimum OFF duration following a short ring in order to avoid missing ringer tones in distinctive ringing.

If this selector is set to "1," when the short-OFF duration is a minimum of 90 ms long, then the equipment will interpret the short-OFF as OFF.

WSW32 (Function setting 10)

Selector No.	Function	Setting and Specifications
1 4	Not used.	
5 6	Default resolution	No. 5 6 0 0 : Standard 0 1 : Fine 1 0 : Super fine 1 1 : Photo
7 8	Default contrast	No. 7 8 0 X : Automatic 1 0 : Super light 1 1 : Super dark

NOTE: Selectors 5 through 8 are applicable to those models equipped with a built-in TAD.

- **Selectors 5 and 6 Default resolution**

These selectors set the default resolution which applies when the equipment is powered up or completes a transaction.

- **Selectors 7 and 8 Default contrast**

These selectors set the default contrast which applies when the equipment is powered up or completes a transaction.

WSW33 (Function setting 11)

Selector No.	Function	Setting and Specifications
1 3	Detection threshold level for voice signals inputted via the telephone line in the built-in TAD operation	No. 1 2 3 0 0 0 : -42.5 dBm (A) 0 0 1 : -44.0 dBm (B) 0 1 0 : -45.5 dBm (C) 0 1 1 : -47.0 dBm (D) 1 0 0 : -48.5 dBm (E) 1 0 1 : -50.0 dBm (F) 1 1 0 : -51.5 dBm (G) 1 1 1 : -53.0 dBm (H)
4 5	FAX receiving speed to be kept within the transmission speed limit to the PC	No. 4 5 0 0 : 14,400 bps 0 1 : 12,000 bps 1 0 : 9,600 bps 1 1 : 7,200 bps
6	Report output of polled transmission requests	0: Yes 1: No
7 8	Comfortable noise level	No. 7 8 0 0 : OFF 0 1 : Low (A) 1 0 : Medium (B) 1 1 : High (C)

NOTE: WSW33 is applicable to those models equipped with a built-in TAD.

NOTE: Selector 6 is not applicable to the U.S.A. versions.

- **Selectors 1 through 3: Detection threshold level for voice signals inputted via the telephone line in the built-in TAD operation**

If the equipment detects voice signals exceeding the threshold level set by these selectors, it will interpret them as effective voice.

- **Selectors 4 and 5: FAX receiving speed to be kept within the transmission speed limit to the PC**

To transmit FAX data being received from other facsimile equipment to the connected PC, you may need to keep the FAX receiving speed within the transmission speed limit to the PC. In an initial negotiation sequence for transmission, the equipment responds to the calling station with the allowable FAX receiving speed specified by these selectors.

- **Selectors 7 and 8: Comfortable noise level**

These selectors set the level of noise to be added during playing-back of voice signals recorded with no-signal compression.

If they are set to "0, 0," no noise will be added.

WSW34 (Function setting 12)

Selector No.	Function	Setting and Specifications
1 3	Erasing time length of ICM tone recorded preceding the tone detection starting point in the case of automatic line disconnection due to no voice signal received	No. 1 2 3 0 0 0 : 0 sec. 0 0 1 : 1 sec. 0 1 0 : 2 sec. 0 1 1 : 3 sec. 1 0 0 : 4 sec. 1 0 1 : 5 sec. 1 1 0 : 6 sec. 1 1 1 : 7 sec.
4 5	No. of CNG cycles to be detected (when the line is connected via the external telephone in the external TAD mode or via the facsimile equipment in F/T or TAD mode)	No. 4 5 0 0 : 0.5 (A) 0 1 : 1 (B) 1 0 : 1.5 (C) 1 1 : 2 (D)
6 7	Number of DTMF tone signals for inhibiting the detection of CNG during external TAD operation	No. 6 7 0 0 : 3 0 1 : 2 1 0 : 1 1 1 : OFF
8	Not used.	

NOTE: Selectors 1 through 5 are applicable to those models equipped with a built-in TAD.

- **Selectors 1 through 3: Erasing time length of ICM tone recorded preceding the tone detection starting point in the case of automatic line disconnection due to no voice signal received**

If the equipment has disconnected the line after detection of disconnection tone in ICM recording, it erases tone recorded preceding the tone detection starting point for the time length set by these selectors.

- **Selectors 4 and 5: No. of CNG cycles to be detected**

The equipment interprets a CNG as an effective signal if it detects a CNG signal by the number of cycles specified by these selectors in any of the following cases:

- when the line is connected via the external telephone in the external TAD mode.
- when the line is connected via the facsimile equipment in F/T or TAD mode.

- **Selectors 6 and 7: Number of DTMF tone signals for inhibiting the detection of CNG during external TAD operation**

If the equipment receives this specified number of DTMF tone signals during external TAD operation, it will not detect CNG afterwards.

If these selectors are set to "1, 1," the CNG detection will not be inhibited.

WSW35 (Function setting 13)

Selector No.	Function	Setting and Specifications																																										
1 4	Detection time length of the disconnection tone in ICM recording	<table border="0"> <tr> <td>No. 1</td> <td>2</td> <td>3</td> <td>4</td> <td>:</td> <td></td> </tr> <tr> <td>0</td> <td>0</td> <td>0</td> <td>0</td> <td>:</td> <td>No detection</td> </tr> <tr> <td>0</td> <td>0</td> <td>0</td> <td>1</td> <td>:</td> <td>1 sec.</td> </tr> <tr> <td>0</td> <td>0</td> <td>1</td> <td>0</td> <td>:</td> <td>2 sec.</td> </tr> <tr> <td>0</td> <td>1</td> <td>0</td> <td>0</td> <td>:</td> <td>4 sec.</td> </tr> <tr> <td></td> <td></td> <td> </td> <td></td> <td>:</td> <td> </td> </tr> <tr> <td>1</td> <td>1</td> <td>1</td> <td>1</td> <td>:</td> <td>15 sec.</td> </tr> </table>	No. 1	2	3	4	:		0	0	0	0	:	No detection	0	0	0	1	:	1 sec.	0	0	1	0	:	2 sec.	0	1	0	0	:	4 sec.					:		1	1	1	1	:	15 sec.
No. 1	2	3	4	:																																								
0	0	0	0	:	No detection																																							
0	0	0	1	:	1 sec.																																							
0	0	1	0	:	2 sec.																																							
0	1	0	0	:	4 sec.																																							
				:																																								
1	1	1	1	:	15 sec.																																							
5 8	Not used.																																											

NOTE: Selectors 1 through 4 are applicable to those models equipped with a built-in TAD.

- Selectors 1 through 4: Detection time length of the disconnection tone in ICM recording**

If the equipment detects disconnection tone for the time length set by these selectors, it will disconnect the line.

WSW36 (Function setting 14)

Selector No.	Function	Setting and Specifications																																													
1 5	Not used.																																														
6 8	Lower limit of frequency to be ignored after detection of calling signals (Ci)	<table border="0"> <tr> <td>No. 6</td> <td>7</td> <td>8</td> <td>:</td> <td></td> </tr> <tr> <td>0</td> <td>0</td> <td>0</td> <td>:</td> <td>0 (Not ignored)</td> </tr> <tr> <td>0</td> <td>0</td> <td>1</td> <td>:</td> <td>4 (448 Hz)</td> </tr> <tr> <td>0</td> <td>1</td> <td>0</td> <td>:</td> <td>8 (244 Hz)</td> </tr> <tr> <td>0</td> <td>1</td> <td>1</td> <td>:</td> <td>12 (162 Hz)</td> </tr> <tr> <td>1</td> <td>0</td> <td>0</td> <td>:</td> <td>16 (122 Hz)</td> </tr> <tr> <td>1</td> <td>0</td> <td>1</td> <td>:</td> <td>20 (97 Hz)</td> </tr> <tr> <td>1</td> <td>1</td> <td>0</td> <td>:</td> <td>24 (81 Hz)</td> </tr> <tr> <td>1</td> <td>1</td> <td>1</td> <td>:</td> <td>28 (69 Hz)</td> </tr> </table>	No. 6	7	8	:		0	0	0	:	0 (Not ignored)	0	0	1	:	4 (448 Hz)	0	1	0	:	8 (244 Hz)	0	1	1	:	12 (162 Hz)	1	0	0	:	16 (122 Hz)	1	0	1	:	20 (97 Hz)	1	1	0	:	24 (81 Hz)	1	1	1	:	28 (69 Hz)
No. 6	7	8	:																																												
0	0	0	:	0 (Not ignored)																																											
0	0	1	:	4 (448 Hz)																																											
0	1	0	:	8 (244 Hz)																																											
0	1	1	:	12 (162 Hz)																																											
1	0	0	:	16 (122 Hz)																																											
1	0	1	:	20 (97 Hz)																																											
1	1	0	:	24 (81 Hz)																																											
1	1	1	:	28 (69 Hz)																																											

- Selectors 6 through 8: Lower limit of frequency to be ignored after detection of calling signals (Ci)**

At the start of reception, if the equipment detects the frequency of calling signals (Ci) specified by selectors 1 through 4 of WSW14, it will start the ringer sounding. When doing so, the equipment may fail to detect the calling signals normally due to noises superimposed at the time of reception. To prevent it, use selectors 6 through 8 of WSW36.

If the equipment detects higher frequencies than the lower limit specified by these selectors, it will regard them as noise and interpret that detecting state as being normal, allowing the ringer to keep sounding (until the equipment starts automatic reception of FAX data if in the FAX mode or enters the TAD mode if set in the TEL mode, according to the preset number of ringers).

WSW37 (Function setting 15)

Selector No.	Function	Setting and Specifications
1 8	Not used.	

[B] Printout of firmware switch data

■ Function

The equipment prints out the setting items and contents specified by the firmware switches.

■ Operating Procedure

- (1) Press the **1** key twice in the initial stage of the maintenance mode.
The "PRINTING" will appear on the LCD.
- (2) The equipment prints out the configuration list as shown in the figure below.
- (3) Upon completion of printing, the equipment returns to the initial stage of the maintenance mode.

CONFIGURATION LIST

MODEL: 8X1-U11
TIME : 01/01/2000 05:33
REV. : UG2952001 VER.A
SUM : 1A9A

```
WSW01 = 00000000
1-2. DIAL FORMAT : NORMAL
3-4. BREAK TIME : 60 MS
5-6. INTERDIGIT PAUSE : 800 MS
7. DP/PB CHANGE IN USER SW : YES
8. DP/PB FIXING SELECTION : PB
WSW02 = 11111010
1-2. ON TIME : 100 MS
3-4. OFF TIME : 140 MS
5-8. LINE BEEP ATTENUATOR : 10 DB
WSW03 = 10000000
1. PARA. CNG DETECTION1 : B
2-4. NOT USED
5. PARA. CNG DETECTION2 : A
6-8. NOT USED
WSW04 = 00010111
1-8. NOT USED
WSW05 = 00000110
1-3. DIAL TONE DETECTION : 3.5 SEC WAITING
4. REMOTE ID DETECTION TIMEOUT : 2 SEC
5-6. BUSY TONE DETECTION (CALLING) : AFTER DIALING
7. BUSY TONE DETECTION (CALLED) : OFF
8. NOT USED
WSW06 = 00101100
1-3. PAUSE KEY : 3.5 SEC WAITING
4-8. NOT USED
WSW07 = 01001100
1-8. NOT USED
WSW08 = 01100100
1-8. NOT USED
WSW09 = 00000000
1. NOT USED
2. NON STANDARD FACILITIES : ON
3-5. NOT USED
6. T1 TIMER : 35 SEC
7-8. CALLING TIMEOUT : 60 SEC
WSW10 = 00010111
1. DPS LINK WITH CML : NO
2. TIMING OF LAST DIGIT-MODEM CHANGE : 100 MS
3. TIMING OF CML ON CNG TRANSMISSION : 2 SEC
4. TIMING OF CML ON CFD TRANSMISSION : 2 SEC
: 2

WSW34 = 00010000
1-5. NOT USED
6-7. DTMF DIGIT FOR CNG DETECTION
8. NOT USED
WSW35 = 01000000
1-8. NOT USED
WSW36 = 00000000
1-5. NOT USED
6-8. IGNORE CI COUNT : 0
WSW37 = 00000101
1-8. NOT USED
```

Configuration List

3.6 Operational Check of LCD

■ Function

This function allows you to check whether the LCD on the control panel works normally.

■ Operating Procedure

- (1) Press the **1** and **2** keys in this order in the initial stage of the maintenance mode.

The LCD shows

- (2) Press the **Start** key. Each time you press the **Start** key, the LCD cycles through the displays shown at right.

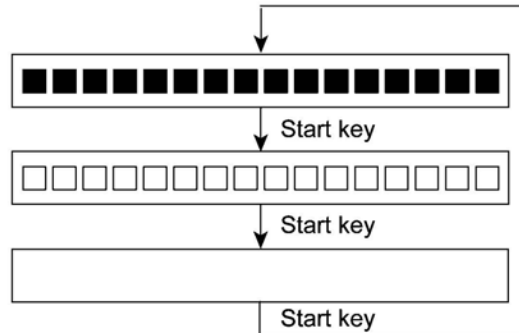

- (3) Press the **Stop** key in any process of the above display cycle. The equipment beeps for one second and returns to the initial stage of the maintenance mode.

3.7 Operational Check of Control Panel PCB

■ Function

This function allows you to check the control panel PCB for normal operation.

■ Operating Procedure

- (1) Press the **1** and **3** keys in this order in the initial stage of the maintenance mode.

The "00 " will appear on the LCD.

- (2) Press the keys and buttons in the order designated in the illustration shown below.

The LCD shows the corresponding number in decimal notation each time a key or button is pressed. Check that the displayed number is correct by referring to the illustration below.

If a key or button is pressed out of order, the equipment beeps and displays the "INVALID OPERATE" on the LCD. To return to the status ready to accept key & button entry for operational check, press the **Stop** key.

- (3) After the last number key or button is pressed, the equipment beeps and returns to the initial stage of the maintenance mode.

To terminate this operation, press the **Stop** key. The equipment returns to the initial stage of the maintenance mode.

FAX255/FAX275/FAX-515/HOMEFAX3

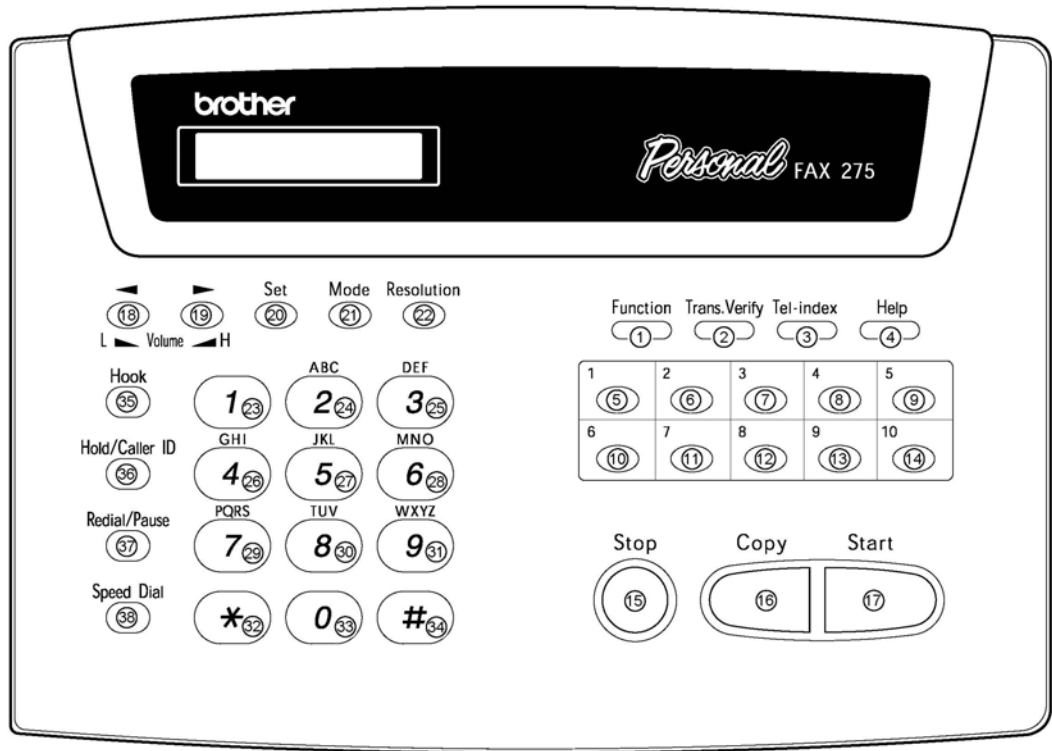

FAX355MC/FAX375MC/FAX-525DT/FAX-525MC

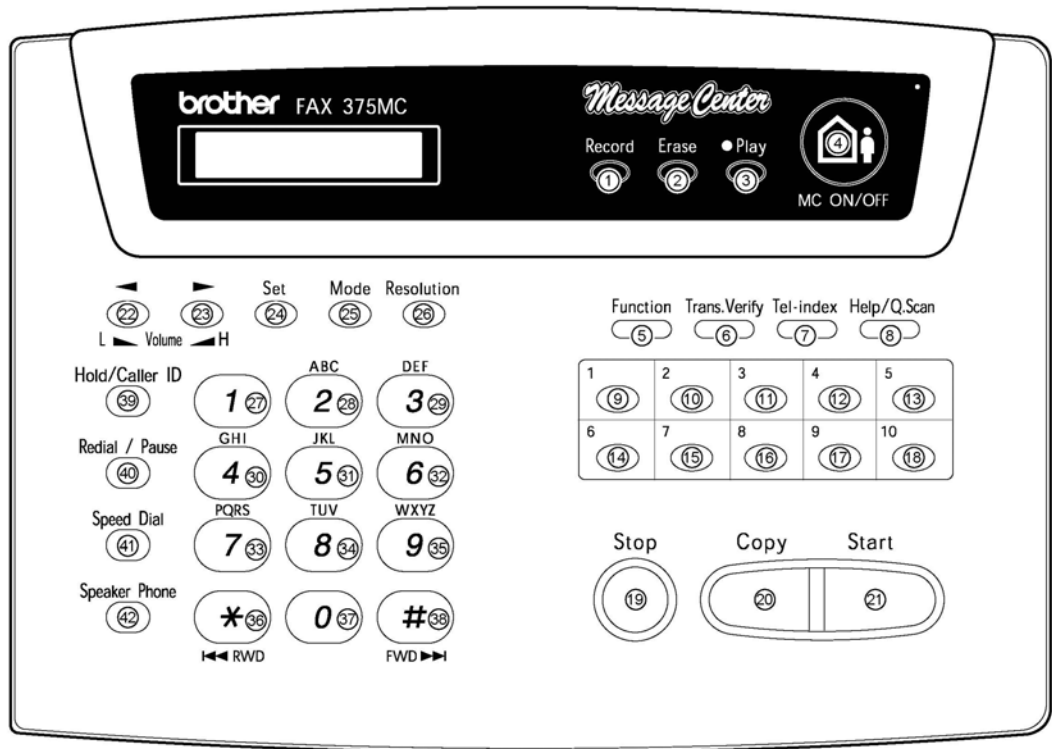

Key & Button Entry Order

3.8 Sensor Operational Check

■ Function

This function allows you to check that the six sensors (document front sensor, document rear sensor, cover sensor, paper empty (PE) sensor, cutter home position (HP) sensor, and hook switch sensor) operate correctly.

■ Operating Procedure

- (1) Press the **3** and **2** keys in this order in the initial stage of the maintenance mode. The equipment sounds 1100 Hz and 400 Hz tones cyclically through the following volumes for testing the speaker.

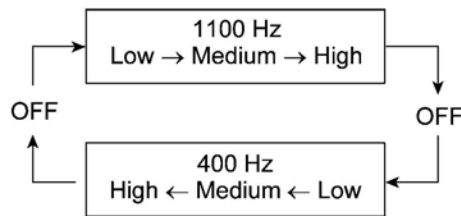

To disable the speaker, press the **Function** key (FAX255/FAX275/FAX355MC/FAX375MC) or **Menu** key (FAX-515/FAX-525DT/FAX-525MC/HOMEFAX3). With the key, you may toggle the speaker on and off.

If the sensing status are as listed below, the LCD will show the following:

FRE RC PE CHK

Given below is the relationship between the LCD indication, sensor name and sensor status.

LCD	Sensors	Sensing status
FRE	Document front and rear sensors	No document detected.
RC	Cover sensor	Recording paper cover ASSY closed.
PE	PE sensor	Recording paper loaded.
CH	Cutter HP sensor	Cutter placed in the home position.
K	Hook switch sensor	On-hook state.

- (2) Change the detecting conditions and check that the displayed letters disappear. For example, insert a document through the document front (or rear) sensor and check that the "F" (or "E") of the FRE disappears.
- (3) To stop this operation, press the **Stop** key. The equipment beeps for one second and returns to the initial stage of the maintenance mode.

3.9 Fine Adjustment of Scanning Start/End Position

■ Function

This function allows you to adjust the scanning start/end position.

■ Operating Procedure

- (1) Press the **5** and **4** keys in this order in the initial stage of the maintenance mode.

The LCD shows the current scanning position correction value as shown at right.

- (2) Press the **Start** key. Each time you press the **Start** key, the LCD cycles through the displays shown at right.

That is, pressing this key cycles through the correction values (mm) as shown below.

0 → -1 → -2 → +1

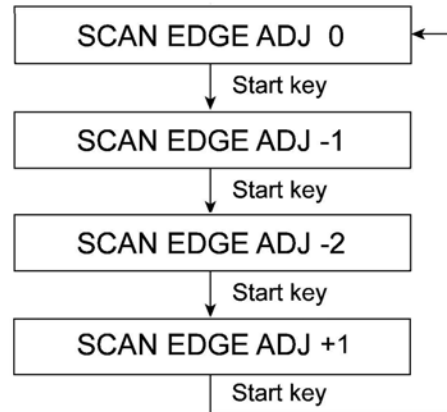

- (3) To stop this operation, press the **Stop** key. The equipment beeps for one second and returns to the initial stage of the maintenance mode.

NOTE: The relationship between the scanning start/end positions and their correction values is shown below.

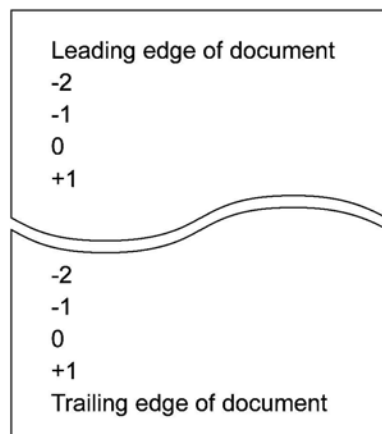

3.10 CIS Scanner Area Setting

■ Function

The equipment sets the CIS scanner area and stores it into the EEPROM.

■ Operating Procedure

(1) In the initial stage of the maintenance mode, set the "adjusting sheet A" on the document stacker.

(2) Press the **5** key twice.

The "SCANNER AREA SET" will appear on the LCD.

The equipment checks and sets the area to be scanned.

If no error is noted, the equipment returns to the initial stage of the maintenance mode.

If any error is noted, the "SCANNER ERROR" will appear on the LCD. To return the equipment to the initial stage of the maintenance mode, press the **Stop** key.

3.11 EEPROM Customizing

■ Function

This function allows you to customize the EEPROM according to language, function settings, and firmware switch settings. The customizing codes list is given in Appendix 1.

NOTE: If you replace the main PCB or CIS, be sure to carry out this procedure.

■ Operating Procedure

(1) Press the **7** and **4** keys in this order in the initial stage of the maintenance mode.

The current customizing code (e.g., 1101 in the case of FAX275 U.S.A. versions) appears.

(2) Enter the desired customizing code (e.g., 0102 in the case of FAX275 Canadian versions).

The newly entered code appears.

NOTE: If a wrong 4-digit code is entered, the equipment will malfunction.

(3) Press the **Start** key.

The equipment saves the setting and returns to the initial stage of the maintenance mode.

If you press the **Stop** key or no keys are pressed for one minute in the above procedure, the equipment stops the procedure and returns to the initial stage of the maintenance mode.

3.12 Equipment Error Code Indication

■ Function

This function displays an error code of the last error on the LCD.

■ Operating Procedure

- (1) Press the **8** and **2** keys in this order in the initial stage of the maintenance mode.
The LCD shows the "MACHINE ERROR _ _".
- (2) To stop this operation and return the equipment to the initial stage of the maintenance mode, press the **Stop** key.

3.13 Output of Transmission Log to the Telephone Line

■ Function

This function outputs the transmission log (that the equipment has stored about the latest transmission) to the telephone line. It allows the service personnel to receive the transmission log of the user's equipment at a remote location and use it for analyzing problems arising in the user's equipment.

■ Operating Procedure

- (1) If the user's equipment has a transmission-related problem, call the user's equipment at a remote location from your equipment.
- (2) If the line is connected, have the user perform the following:
 - 1) For FAX255/FAX275/FAX355MC/FAX375MC: Press the **Function**, **Mode**, and **0** keys in this order.
For FAX-515/FAX-525DT/FAX-525MC/HOMEFAX3: Press the **Menu**, **Mode**, and **0** keys in this order.
 - 2) Press the **8** and **7** keys.
The above operation makes the user's equipment send CNG to your equipment for sending the transmission log.
- (3) If you hear the CNG sent from the user's equipment, press the **Start** key of your equipment.
Your equipment will start to receive the transmission log from the user's equipment.

3.14 Document Draw Adjustment

After replacement of the main PCB or CIS, or if data stored in the EEPROM is damaged, you need to carry out this procedure by using the TC-027 chart.

■ Function

This function adjusts how much the document is drawn in, starting at the point when the document rear sensor is turned on until the leading edge of the document reaches the scanning start position.

■ Operating Procedure

(1) In the initial stage of the maintenance mode, set the TC-027 chart on the document stacker.
The message "DOC. READY" appears on the LCD.

(2) For FAX255/FAX275/FAX355MC/FAX375MC: Press the **Function** key.

For FAX-515/FAX-525DT/FAX-525MC/HOMEFAX3: Press the **Menu** key.

The equipment beeps and draws in the TC-027 chart to the scanning start position. While drawing it in, the equipment counts patterns on the chart to determine the amount of draw.

Upon completion of normal counting, the equipment shows the message "COPY P.01 SUP" on the LCD and begins copying the TC-027 chart. The message "REAR SENSOR IS ADJUSTED." and the copied image will be printed out on recording paper as shown below.

If any error occurs during counting, the message "MACHINE ERROR AB" appears on the LCD, with no copying of the TC-027 chart onto the recording paper. However, only the message "REAR SENSOR IS ADJUSTED." will be printed out.

REAR SENSOR IS ADJUSTED.

TC-027

1997.6.2

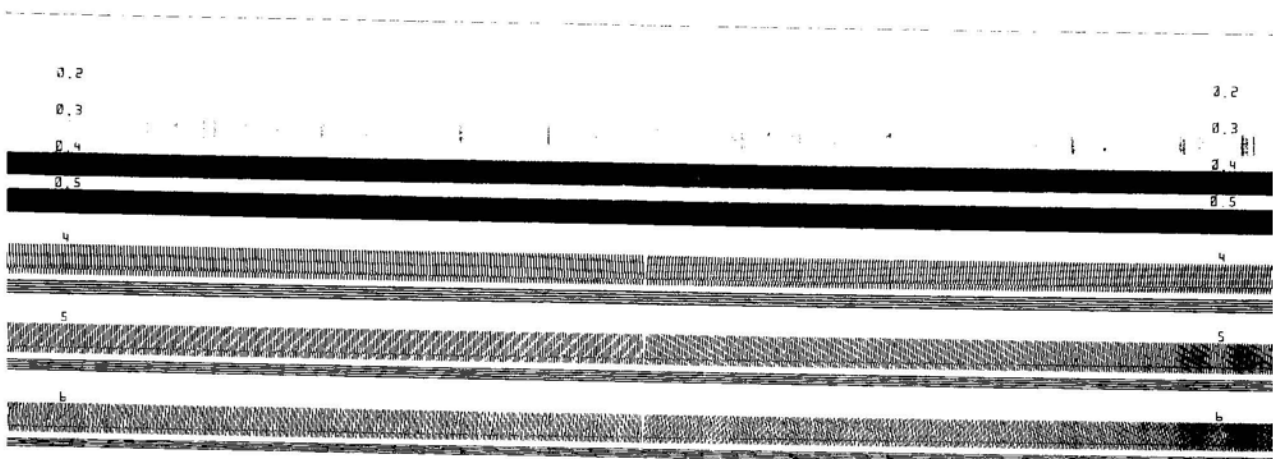

Printout after Normal Completion of Document Draw Adjustment

CHAPTER VI.

ERROR INDICATION AND TROUBLESHOOTING

CHAPTER VI. ERROR INDICATION AND TROUBLESHOOTING

CONTENTS

1. ERROR INDICATION	VI-1
1.1 Equipment Errors	VI-1
[1] Error messages on the LCD	VI-1
[2] Error codes shown in the "MACHINE ERROR <u>XX</u> " message	VI-3
1.2 Communications Errors.....	VI-4
2. TROUBLESHOOTING	VI-11
2.1 Introduction	VI-11
2.2 Precautions	VI-11
2.3 Checking prior to Troubleshooting	VI-11
2.4 Troubleshooting Procedures	VI-12
[1] Control panel related.....	VI-12
[2] Telephone related	VI-12
[3] Communications related	VI-13
[4] Paper/document feeding related	VI-13
[5] Print-image related.....	VI-14

1. ERROR INDICATION

To help the user or the service personnel promptly locate the cause of a problem (if any), the facsimile equipment incorporates the self-diagnostic functions which display error messages for equipment errors and communications errors.

For the communications errors, the equipment also prints out the transmission verification report and the communications list.

1.1 Equipment Errors

If an equipment error occurs, the facsimile equipment emits an audible alarm (continuous beeping) for approximately 4 seconds and shows the error message on the LCD. For the error messages, see [1] below. As one of the error messages, "MACHINE ERROR XX" includes an error code which indicates the detailed error causes listed in [2]. To display an error code for the other latest error message, make the equipment enter the maintenance mode and press [8] and [2] keys (for details, refer to Chapter V, Section 3.12).

[1] Error messages on the LCD

Messages on the LCD	Probable Cause
PAPER ROLL EMPTY	The paper empty (PE) sensor detects that no recording paper is present.
PRINTER JAM	The recording paper failed to return to the printing position after it had been cut.
COVER OPEN	The cover sensor detects that the control panel ASSY is not closed.
DOCUMENT JAM	<ul style="list-style-type: none">■ Document jam(1) The document length exceeds the limitation (400 or 90 cm) registered by firmware switch WSW16. (Refer to Chapter V, Section 3.5.) (Both the document front and rear sensors stay ON even after the document has been fed by the registered length.)(2) The document rear sensor detects no trailing edge of a document after the document has been fed by 400 cm. (The document rear sensor stays ON even after the document has been fed when the document front and rear sensors were OFF and ON, respectively.)

Messages on the LCD	Probable Cause
DOCUMENT JAM	<ul style="list-style-type: none"> ■ Document loading error (1) The document rear sensor detects no leading edge of a document within 10 seconds from the start of document loading operation. (The document rear sensor stays OFF even after the document has been fed when the document front sensor was ON.) (2) The loaded document is too short. (Since the document is shorter than the distance between the document front and rear sensors, the document front sensor is turned OFF before the document rear sensor is turned ON.)
CUTTER JAM	The upper rotary blade of the automatic cutter failed to return to the home position within the specified time after cutting the recording paper.
CLEAN UP SCANNER	In the scanning compensation data list printed by the maintenance-mode function No. 05, less than fifty percent of the white level data is faulty. (This message may appear only in the maintenance mode.)
SCANNER ERROR	In the scanning compensation data list printed by the maintenance-mode function No. 05, fifty percent or more of the white level data is faulty. (This message may appear only in the maintenance mode.)
PRINTER FAULT	The thermistor in the recording head caused a heat error.
PC BUSY OR FAIL*	After connected with the host computer, the equipment has received no response from the computer. (A communications error has occurred.)
CONNECTION FAIL**	After connected with the host computer or optional handy scanner, the equipment has received no response from the computer or handy scanner. (A communications error has occurred.)
MACHINE ERROR XX	"XX" indicates an error code. Refer to Section [2] on the next page.

* This message has prepared only for those versions that do not support an optional handy scanner.

** This message has prepared only for those versions that support an optional handy scanner.

If only an alarm beep is heard without any message on the LCD when the equipment is powered up, the ROM or RAM will be defective.

[2] Error codes shown in the "MACHINE ERROR XX" message

Error Code XX (Hex.)	Error factor
(87	Fails to complete the sequence of recording operation.)
(89	Cutter jam.)
8A	Wrong or weak contact of the recording head connectors.
(8B	Recording head overheat.)
(A1	Recording paper cover opened.)
(A2	Document too long to scan.)
(A3	Document not detected by the document rear sensor.)
(A4	50% or more faulty of white level data.) *
(A5	Faulty operation of DMA0 during scanning.)
(A6	Faulty operation of DMA1 during scanning.)
(A7	One-line feeding time-out error.)
(A8	One-line scanning time-out error.)
(A9	Abnormal scanning reference voltage.)
(AB	Document feed-in amount measuring error.) *
(AC	Less than 50% faulty of white level data.) *
(B9	Light emission intensity error of the LED array.)
(BE	Abnormal clamp PWM value)
(BF	Light emission intensity error of the LED array at the setting time of initial values.) *
(D5	The MODEM fails to complete the command transmission sequence.)
(D6	No MODEM interrupt for 60 seconds.)
(E4	Out of recording paper.)
E6	Write error in E ² PROM.
(E8	Data scanning error during transmission.)
F3	Voice message recording or playing-back not started.
(F5	EOL not found in page memory transmission mode.)
(F6	PC interface error.)
(F7	Optional handy scanner interface error.)

Error codes in parentheses do not appear in the "MACHINE ERROR XX", since those errors are displayed as messages described in "[1] Error messages on the LCD." You can display those error codes in the maintenance mode (Function code 82). Those error codes appear in the communications error list if an equipment error occurs during communications. Refer to Section 1.2, (13).

* Those codes marked with an asterisk can appear only in the maintenance mode.

1.2 Communications Errors

If a communications error occurs, the facsimile equipment

- (1) emits an audible alarm (intermittent beeping) for approximately 4 seconds,
- (2) displays the corresponding error message, and
- (3) prints out the transmission verification report if the equipment is in sending operation.

■ Definition of Error Codes on the Communications List

(1) Calling

Code 1	Code 2	Causes
10	08	Wrong number called.
11	01	No dial tone detected before start of dialing.
11	02	Busy tone detected before dialing.
11	03	2nd dial tone not detected.
11	05	No loop current detected. *
11	06	Busy tone detected after dialing or called.
11	07	No response from the remote station in sending.
11	10	No tone detected after dialing.
17	07	No response from the calling station in receiving.

* Available in Germany and Austria only.

(2) Command reception

Code 1	Code 2	Causes
20	01	Unable to detect a flag field.
20	02	Carrier was OFF for 200 ms or longer.
20	03	Abort detected ("1" in succession for 7 bits or more).
20	04	Overflow detected.
20	05	A frame for 3 seconds or more received.
20	06	CRC error in answer back.
20	07	Undefined command received.
20	08	Invalid command received.
20	09	Command ignored once for document setting or for dumping-out at turn-around transmission.
20	0A	T5 time-out error
20	0B	CRP received.
20	0C	EOR and NULL received.

(3) Compatibility [checking the NSF and DIS]

Code 1	Code 2	Causes
32	01	Remote terminal only with V.29 capability in 2400 or 4800 bps transmission.
32	02	Remote terminal not ready for polling.
32	10	Remote terminal not equipped with password function or its password switch OFF.
32	11	Remote terminal not equipped with or not ready for confidential mail box function.
32	12	Remote terminal not equipped with or not ready for relay broadcasting function.
32	13	No confidential mail in the remote terminal.
32	14	The available memory space of the remote terminal is less than that required for reception of the confidential or relay broadcasting instruction.

(4) Instructions received from the remote terminal [checking the NSC, DTC, NSS, and DCS]

Code 1	Code 2	Causes
40	02	Illegal coding system requested.
40	03	Illegal recording width requested.
40	05	ECM requested although not allowed.
40	06	Polled while not ready.
40	07	No document to send when polled.
40	10	Nation code or manufacturer code not coincident.
40	11	Unregistered group code entered for relay broadcasting function, or the specified number of broadcasting subscribers exceeding the limit.
40	12	Retrieval attempted when not ready for retrieval.
40	13	Polled by any other manufacturers' terminal while waiting for secure polling.
40	17	Invalid resolution selected.

(5) Command reception [checking the NSF and DIS after transmission of NSS and DCS]

Code 1	Code 2	Causes
50	01	Vertical resolution capability changed after compensation of background color.

(6) ID checking

Code 1	Code 2	Causes
63	01	Password plus "lower 4 digits of telephone number" not coincident.
63	02	Password not coincident.
63	03	Polling ID not coincident.
63	04	Entered confidential mail box ID uncoincident with the mail box ID.
63	05	Relay broadcasting ID not coincident.
63	06	Entered retrieval ID uncoincident with that of the mail box ID.

(7) DCN reception

Code 1	Code 2	Causes
74		DCN received.

(8) TCF transmission/reception

Code 1	Code 2	Causes
80	01	Fallback impossible.

(9) Signal isolation

Code 1	Code 2	Causes
90	01	Unable to detect video signals and commands within 6 seconds after CFR is transmitted.
90	02	Received PPS containing invalid page count or block count.

(10) Video signal reception

Code 1	Code 2	Causes
A0	03	Error correction sequence not terminated even at the final transmission speed for fallback.
A0	11	Receive buffer empty. (5-second time-out)
A0	12	Receive buffer full during operation except receiving into memory.
A0	13	Decoding error continued on 500 lines.
A0	14	Decoding error continued for 10 seconds.
A0	15	Time-out: Five seconds or more for one-line transmission.
A0	16	RTC not found and carrier OFF signal detected for 6 seconds.
A0	17	RTC found and command detected for 60 seconds.
A8	01	RTN, PIN, or ERR received at the calling terminal. *
A9	01	RTN, PIN, or ERR received at the called terminal. *
AA	18	Receive buffer full during receiving into memory.

* Available in Germany and Austria only.

(11) General communications-related

Code 1	Code 2	Causes
B0	01	Polarity inversion detected.
B0	02	Unable to receive the next-page data.
B0	03	Unable to receive polling even during turn-around transmission due to call reservation.
B0	04	PC interface error.

(12) Maintenance mode

Code 1	Code 2	Causes
E0	01	Failed to detect 1300 Hz signal in burn-in operation.
E0	02	Failed to detect PB signals in burn-in operation.
E0	03	Failed to detect any command from the RS-232C interface in burn-in operation.

(13) Equipment error

Code 1	Code 2	Causes
FF	XX	Equipment error (For XX, refer to Subsection 1.1 [2].)

2. TROUBLESHOOTING

2.1 Introduction

This section gives the service personnel some of the troubleshooting procedures to be followed if an error or malfunction occurs with the facsimile equipment. It is impossible to anticipate all of the possible problems which may occur in future and determine the troubleshooting procedures, so this section covers some sample problems. However, those samples will help service personnel pinpoint and repair other defective elements if he/she analyzes and examines them well.

2.2 Precautions

Be sure to observe the following to prevent the secondary troubles from happening:

- (1) Always unplug the AC power cord from the outlet when removing the covers and PCBs, adjusting the mechanisms, or conducting continuity testing with a circuit tester.
- (2) When disconnecting the connectors, do not pull the lead wires but hold the connector housings.
- (3)
 - Before handling the PCBs, touch a metal portion of the machine to discharge static electricity charged in your body.
 - When repairing the PCBs, handle them with extra care.

After repairing the defective section, be sure to check again if the repaired section works correctly. Also record the troubleshooting procedure so that it would be of use for future trouble occurrence.

2.3 Checking prior to Troubleshooting

Prior to proceeding to the troubleshooting procedures, check that:

- (1) Each voltage level on AC input lines and DC lines is correct.
- (2) All cables and harnesses are firmly connected.
- (3) None of the fuses are blown.

2.4 Troubleshooting Procedures

[1] Control panel related

Trouble	Check:
(1) LCD shows nothing.	<ul style="list-style-type: none"> • Main-panel harness between the main PCB and the control panel PCB • Interfaces between the main PCB, NCU PCB and power supply PCB • Control panel PCB • Power supply PCB • Main PCB
(2) Control panel inoperative.	<ul style="list-style-type: none"> • Main-panel harness between the main PCB and the control panel PCB • Interfaces between the main PCB, NCU PCB and power supply PCB • Control panel PCB • FPC key • Main PCB

[2] Telephone related

Trouble	Check:
(1) No phone call can be made.	<ul style="list-style-type: none"> • FPC key • Control panel PCB by using the maintenance-mode function No. 13. If any defective keys are found, replace them. (Refer to Chapter V, Section 3.7.) • NCU PCB • Main PCB
(2) Speed dialing or one-touch dialing will not work.	<ul style="list-style-type: none"> • Ordinary dialing function (other than the speed and one-touch dialing) <p>If it works normally, check the main PCB; if not, refer to item (1) above.</p>
(3) Speaker silent during on-hook dialing.	<ul style="list-style-type: none"> • Ordinary dialing function (other than the on-hook dialing with the hook key) <p>If it works normally, proceed to the following checks; if not, refer to item (1) above.</p>
(4) Dial does not switch between tone and pulse.	<ul style="list-style-type: none"> • Main PCB

Trouble	Check:
(5) Telephone does not ring.	<ul style="list-style-type: none"> • Speaker • NCU PCB • Main PCB

[3] Communications related

Trouble	Check:
(1) No tone is transmitted.	<ul style="list-style-type: none"> • Main PCB • NCU PCB

[4] Paper/document feeding related

Trouble	Check:
(1) Neither "COPY: PRESS COPY" nor "FAX: NO. & START" message appears although documents are set.	<ul style="list-style-type: none"> • Sensors by using the maintenance-mode function No. 32. (Refer to Chapter V, Section 3.8.) • Actuators of the document front and rear sensors • Main PCB
(2) Document not fed.	<ul style="list-style-type: none"> • ADF and its related sections • Drive motor and its harness • White pressure roller and its related gears • Solenoid and the planetary gear train • Main PCB
(3) Recording paper not fed.	<ul style="list-style-type: none"> • ADF and its related sections • Drive motor and its harness • Platen and its related gears • Solenoid and the planetary gear train • Main PCB
(4) The "CUTTER JAM" message cannot be removed.	<ul style="list-style-type: none"> • Drive motor and its harness • Cutter HP sensor and its position • Cutter gear • Solenoid and the planetary gear train • Main PCB

[5] Print-image related

If the received or sent image has any problem, first make a copy with the facsimile equipment.

If the copied image is normal, the problem may be due to the remote terminal; if it is abnormal, proceed to the following checks:

Trouble	Check:
(1) Completely blank <u>At the scanner</u> <u>At the recorder</u>	<ul style="list-style-type: none"> • Main PCB • Recording head harness • Compression springs beneath the recording head • Recording head • Main PCB
(2) White vertical streaks <u>At the scanner</u> <u>At the recorder</u>	<ul style="list-style-type: none"> • CIS unit • Recording head
(3) All black <u>At the scanner</u> <u>At the recorder</u>	<ul style="list-style-type: none"> • CIS harness • CIS unit • Main PCB • Recording head harness • Recording head • Main PCB
(4) Black vertical streaks <u>At the scanner</u> <u>At the recorder</u>	<ul style="list-style-type: none"> • CIS unit • Recording head
(5) Light or dark <u>At the scanner</u> <u>At the recorder</u>	<ul style="list-style-type: none"> • CIS unit • Main PCB • Compression springs beneath the recording head

Trouble	Check:
<p>(6) Faulty image registration</p> <p><u>At the scanner</u></p> <p><u>At the recorder</u></p>	<ul style="list-style-type: none"> • CIS harness • CIS unit • Main PCB • Recording head harness • Main PCB
<p>(7) Image distortion</p> <p><u>In communications</u></p> <p><u>At the scanner</u></p> <p><u>At the recorder</u></p>	<ul style="list-style-type: none"> • Error code displayed (Refer to Section 1, "ERROR INDICATION" in this chapter.) • NCU PCB • Main PCB • Separation roller and its related sections • White pressure roller and its related gears • Solenoid and the planetary gear train • Drive motor and its harness • Main PCB • Compression springs beneath the recording head • Platen and its related gears • Solenoid and the planetary gear train • Drive motor and its harness • Main PCB

brother®

**FAX255/FAX275/FAX355MC/FAX375MC
FAX-515/FAX-525DT/FAX-525MC/HOMEFAX3**

Appendix 1. EEPROM Customizing Codes

EEPROM Customizing Codes

This function allows you to customize the EEPROM according to language, function settings, and firmware switch settings. The customizing codes list is given on the next page.

■ Operating Procedure

- (1) FAX255/FAX275/FAX355MC/FAX375MC: Press the **Function**, *, **2**, **8**, **6**, and **4** keys in this order to make the equipment enter the maintenance mode.

← Within 2 seconds →

FAX-515/FAX-525DT/FAX-525MC/HOMEFAX3: Press the **Menu**, *, **2**, **8**, **6**, and **4** keys in this order to make the equipment enter the maintenance mode.

← Within 2 seconds →

The equipment beeps for approx. one second and displays " ■■ MAINTENANCE ■■■ " on the LCD.

- (2) Press the **7** and **4** keys in this order in the initial stage of the maintenance mode.
The current customizing code (e.g., 1101 in the case of FAX275 U.S.A. versions) appears.
- (3) Enter the desired customizing code (e.g., 0102 in the case of FAX275 Canadian versions).
The newly entered code appears.

NOTE: If a wrong 4-digit code is entered, the equipment will malfunction.

- (4) Press the **Start** key.

The equipment saves the setting and returns to the initial stage of the maintenance mode.

If you press the **Stop** key or no keys are pressed for one minute in the above procedure, the equipment stops the procedure and returns to the initial stage of the maintenance mode.

■ EEPROM Customizing Codes List

Versions	Model			
	FAX255	FAX275	FAX355MC	FAX375MC
U.S.A.	1001 (3001)	1101 (3101)	1001 (3001)	1001 (3001)
CANADA	0002 (2002)	0102 (2102)	0002 (2002)	0002 (2002)
CHINA	---	0020	---	0020
TAIWAN	0023	0123	---	0023
HONG KONG	---	0140	---	0040
ARGENTINA	---	0135	---	0035
THAILAND	---	0041	---	0041
CHILLE	0035	0135	---	0035
ASIA	0040	0140	---	0040
GULF	---	0041	---	0041
BRAZIL	---	4101 (6101)	---	4001 (6001)
INDONESIA	---	0140	---	0040
INDIA	---	0045	---	0045
MEXICO	0035	0135	---	0035
RUSSIA	---	0041	---	0041

NOTE: Codes in parentheses should apply if the side of the CIS unit has a special marking.

Versions	Model			
	FAX-515	FAX-525DT	FAX-525MC	HOMEFAX3
GERMANY	0003	0003	---	---
U.K.	0004	0004	---	---
FRANCE	0005	0005	---	---
NORWAY	0007	---	---	---
BELGIUM	0008	0008	---	---
NETHERLANDS	0009	0009	---	---
SWITZERLAND	0010	0010	---	---
IRELAND	0011	0011	---	---
FINLAND	0012	0012	---	---
DENMARK	0013	---	---	---
AUSTRIA	0014	0014	---	---
SPAIN	0015	0015	---	---
ITALY	0016	0016	---	---
ISRAEL	0004	---	---	---
PORTUGAL	0018	---	---	---
SWEDEN	0026	---	---	---
AUSTRALIA	0006	---	0006	---
NEW ZEALAND	0027	---	0027	0027

**FAX255/FAX275/FAX355MC/FAX375MC
FAX-515/FAX-525DT/FAX-525MC/HOMEFAX3**

Appendix 2. Circuit Diagrams

- A. Main PCB
- B. Network Control Unit (NCU) PCB
- C. Control Panel PCB
- D. Power Supply PCB

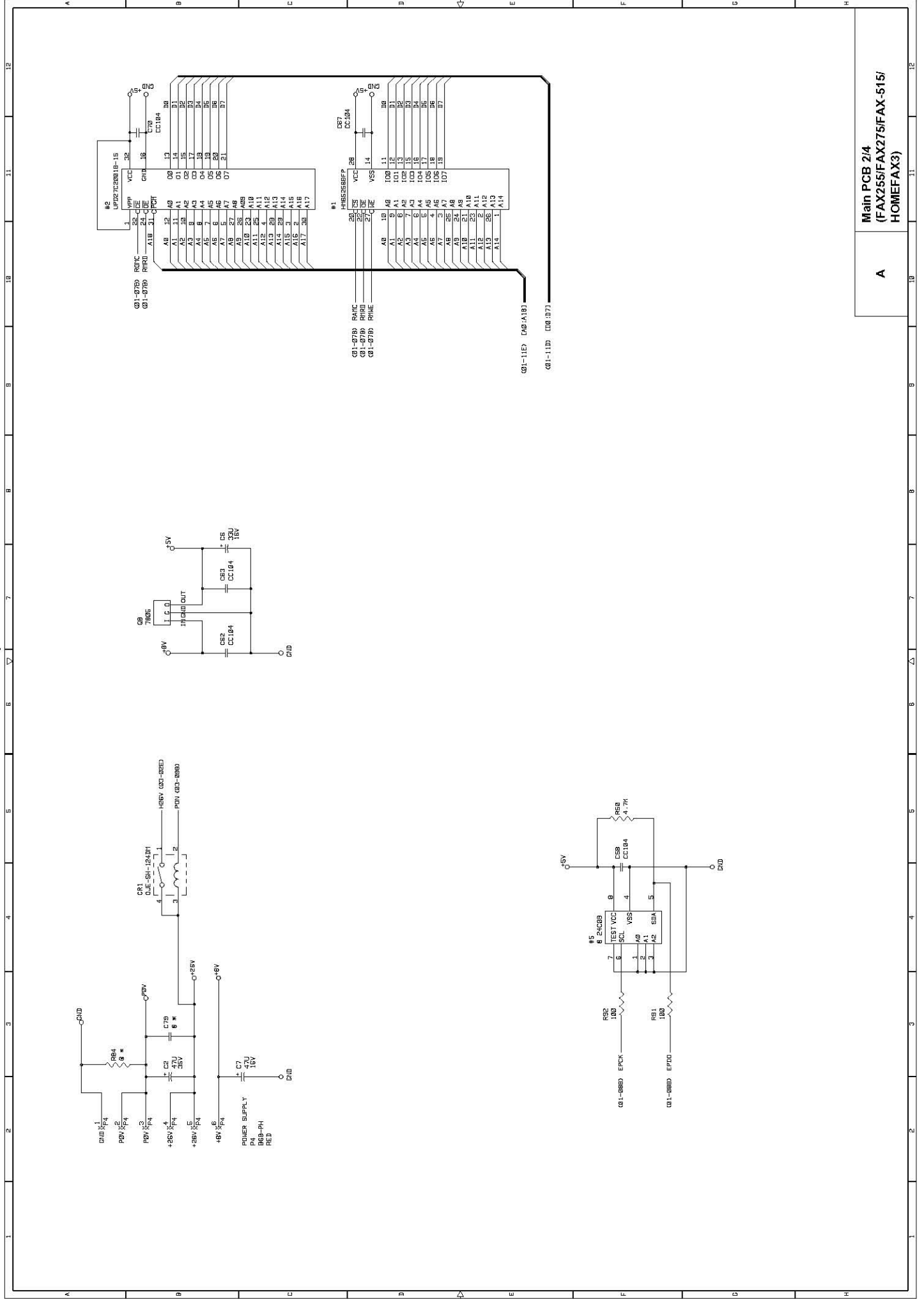

Main PCB 2/4
(FAX255/FAX275/FAX-515/
HOMEFAX3)

A

NOTE:RQV SHORTED TO GND AT ONE POINT
 NOTE:RSV SHORTED TO +5V AT ONE POINT

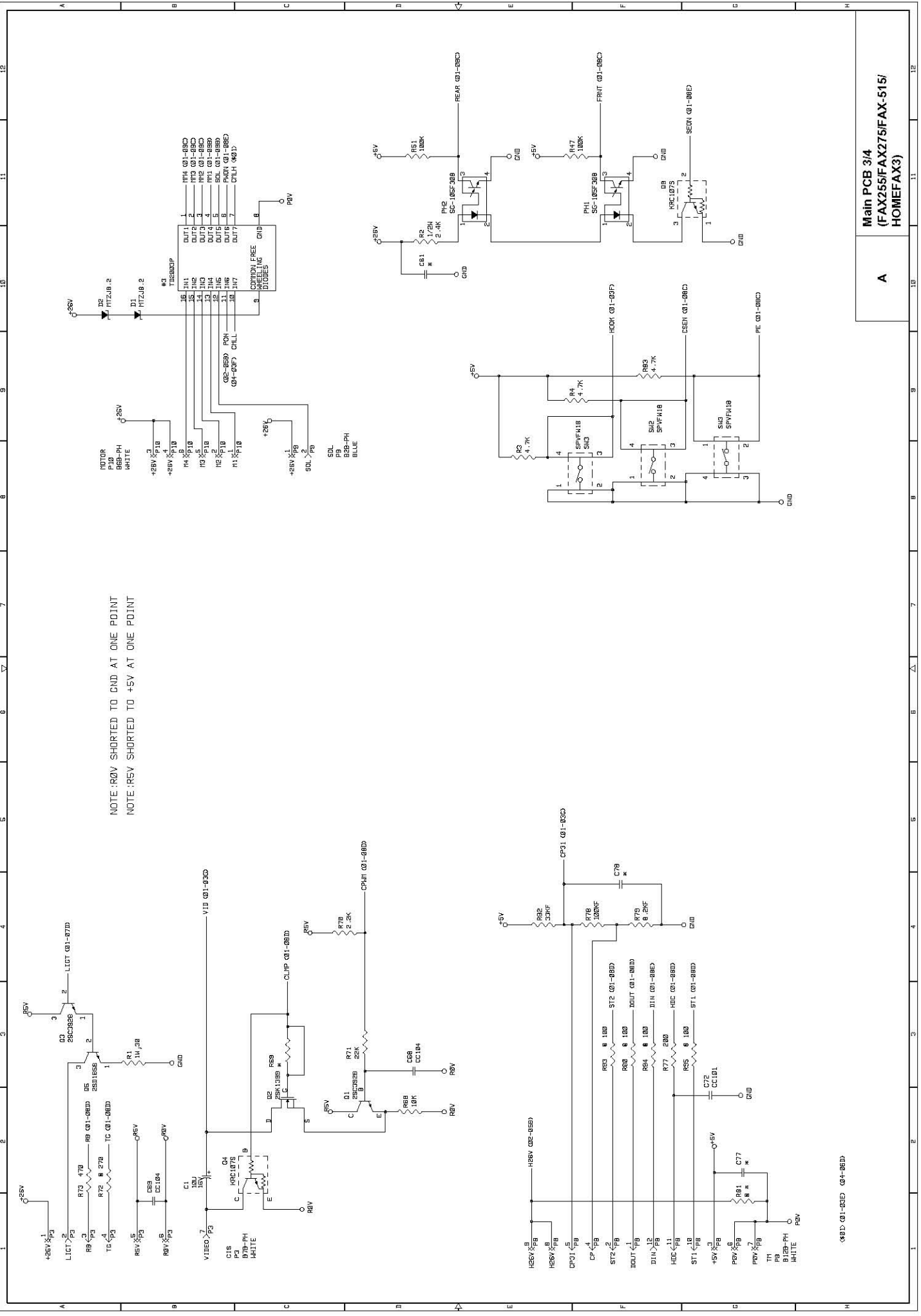

Main PCB 3/4
 (FAX255/FAX275/FAX-515/
 HOMEFAX3)

A

Q40D Q01-Q02E Q04-Q02D

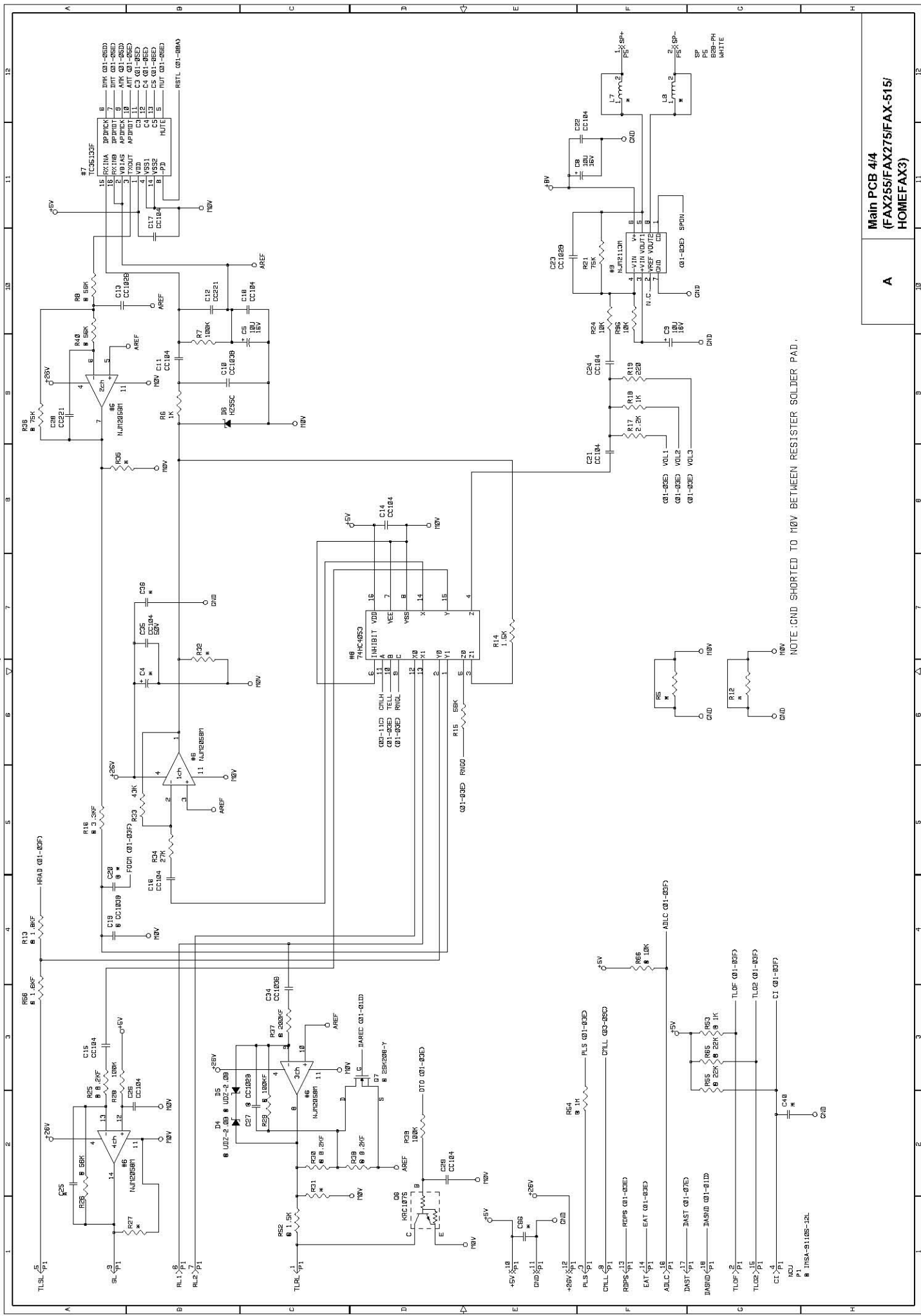

NOTE: GND SHORTED TO 18V BETWEEN RESISTER SOLDER PAD.

Main PCB 4/4
(FAX255/FAX275/FAX-515/
HOMEFAX3)

A

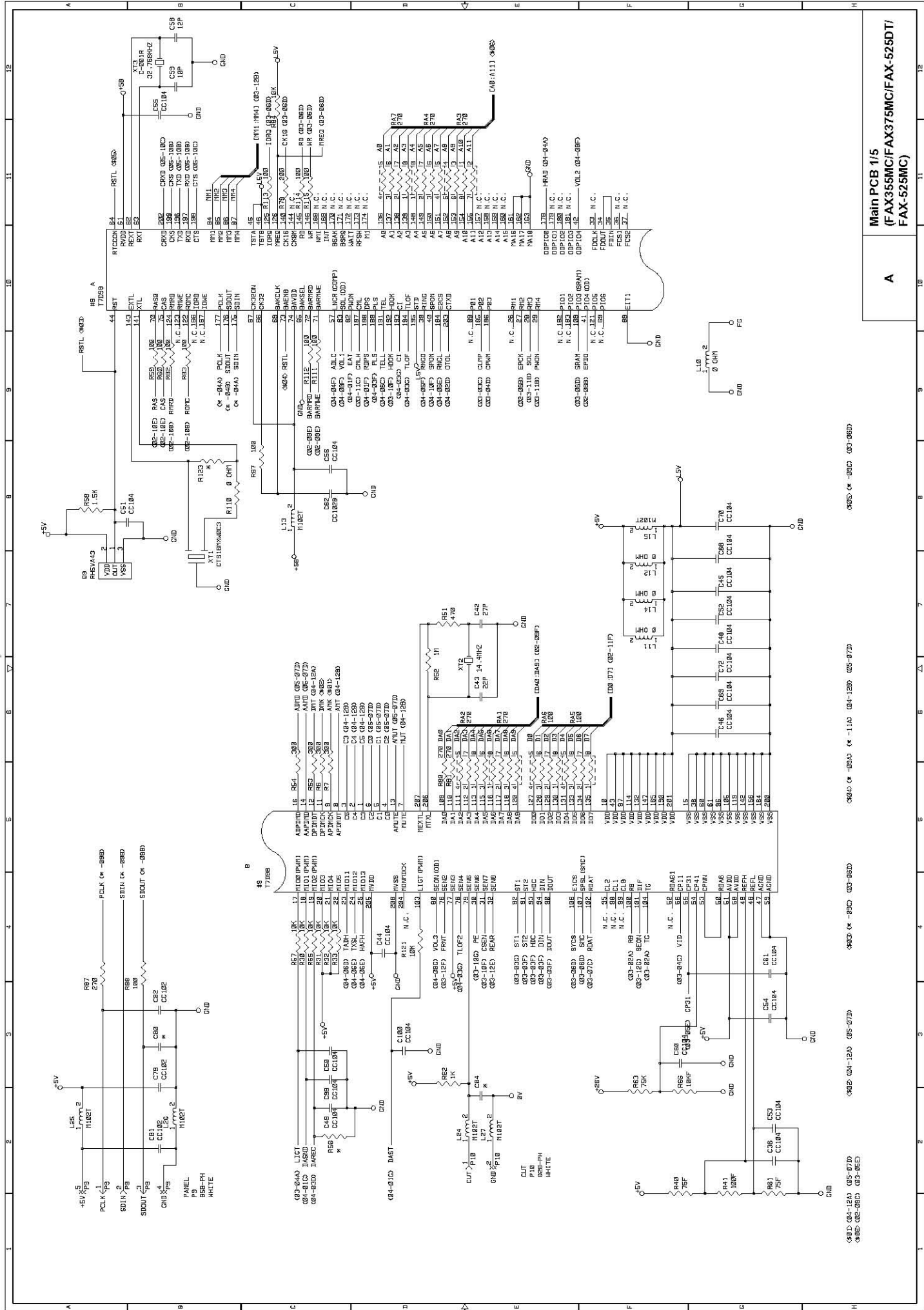

Main PCB 1/5
(FAX355MC/FAX375MC/FAX-525D1/
FAX-525MC)

A

Q302: Ck -03C3 (03-083D)

Q304: Ck -03A3 (04-12B) (05-077D)

Q303: Ck -03C3 (03-083D)

Q302: Q4-12A3 (05-077D)

Q310: Q4-12A3 (05-077D)
 Q305: Q2-08C3 (03-05C)

Q305: Ck -03C3 (03-083D)

Q305: Ck -03C3 (03-083D)

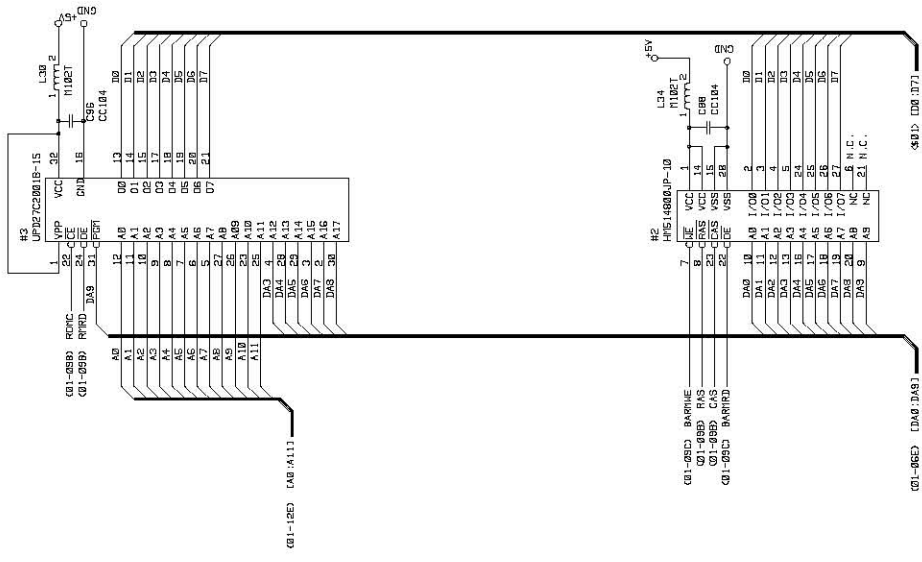
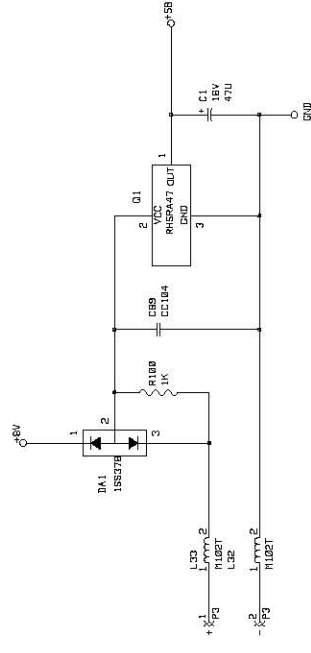
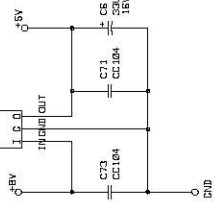
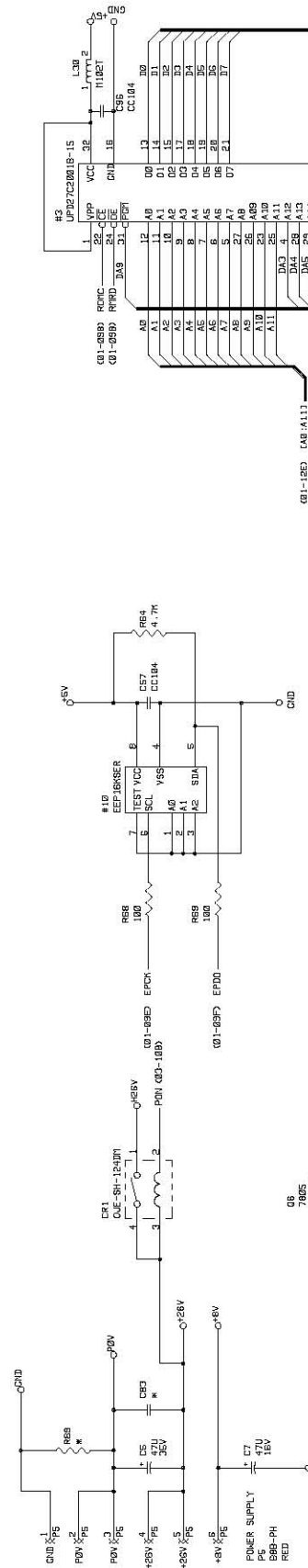

430 D 01-06F 01-06E

A

Main PCB 2/5
(FAX355MC/FAX375MC/FAX-525DT/
FAX-525MC)

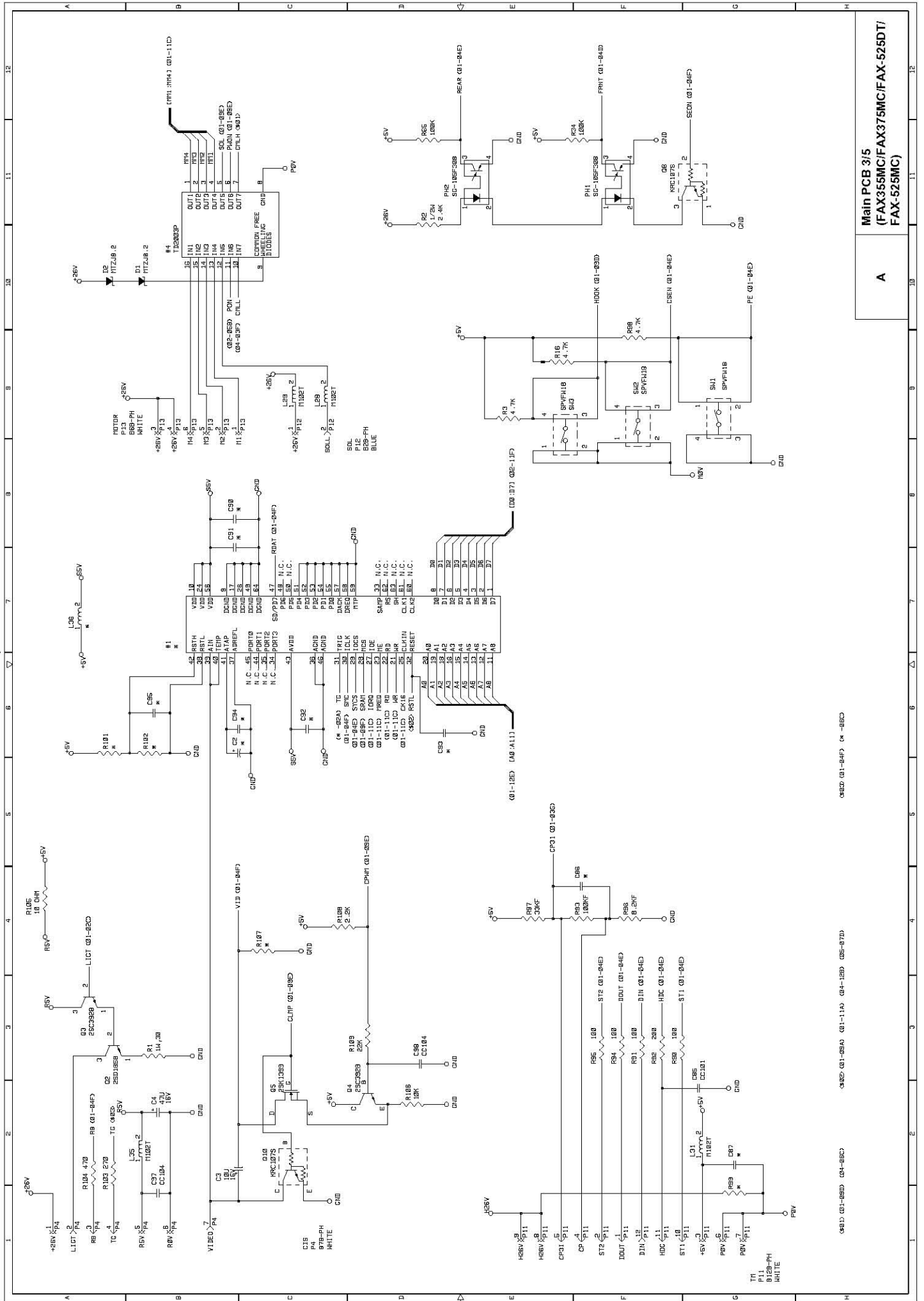

Main PCB 3/5
(FAX355MC/FAX375MC/FAX525DT/
FAX525MC)

A

CONN 01-04F (A1-11)

CONN 01-04E (A1-11A) (A4-123) (A5-177D)

CONN 01-04D (A4-123) (A5-177D)

CONN 01-04B (A4-123) (A5-177D)

CONN 01-04A (A4-123) (A5-177D)

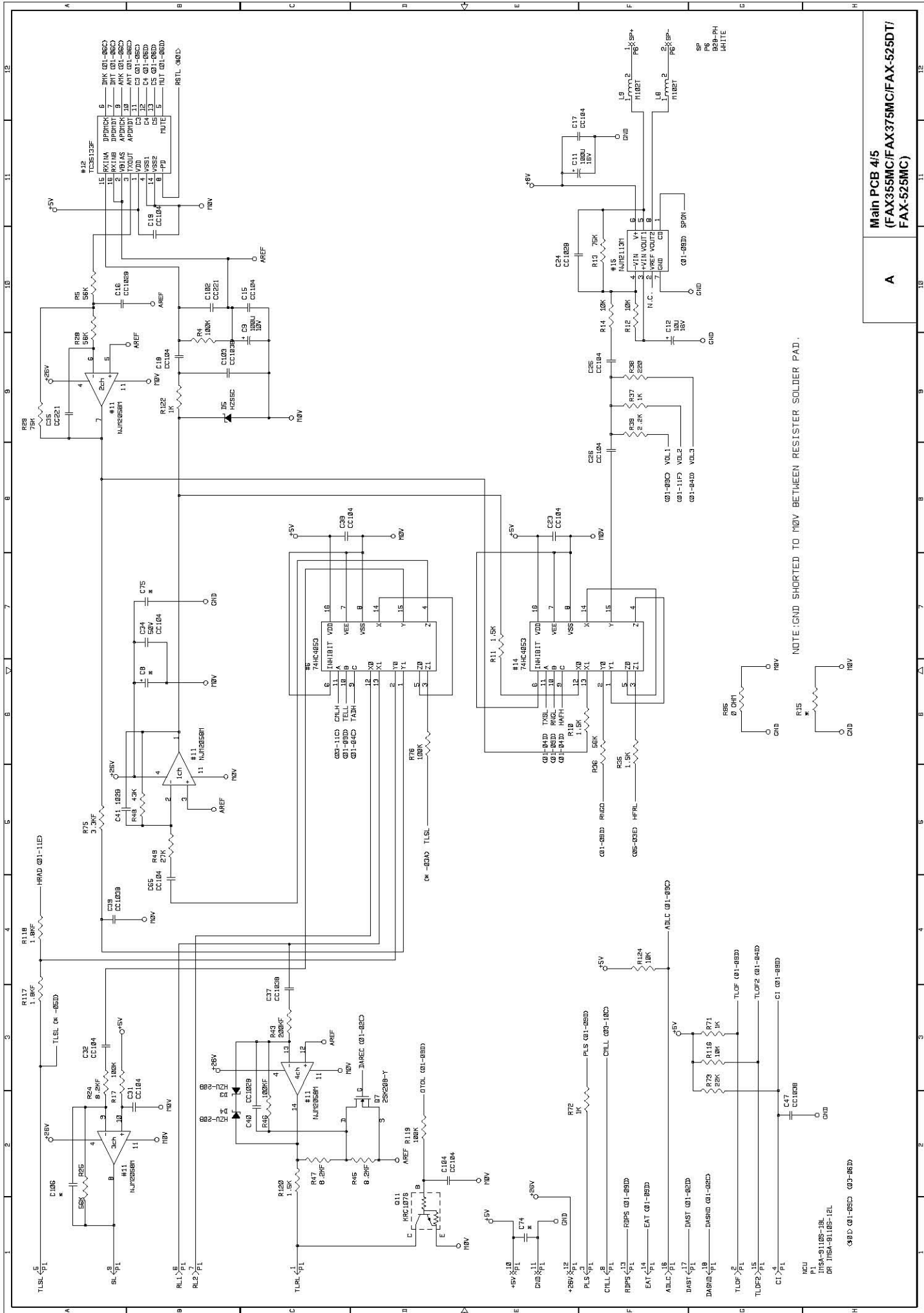

Main PCB 4/5
(FAX355MC/FAX375MC/FAX-525DT/
FAX-525MC)

A

NOTE: GND SHORTED TO 10V BETWEEN RESISTOR SOLDER PAD.

430 D 01-05C3 01-06D

ICU
P1
P2
P3
P4
P5
P6
P7
P8
P9
P10
P11
P12
P13
P14
P15
P16
P17
P18
P19
P20
P21
P22
P23
P24
P25
P26
P27
P28
P29
P30
P31
P32
P33
P34
P35
P36
P37
P38
P39
P40
P41
P42
P43
P44
P45
P46
P47
P48
P49
P50
P51
P52
P53
P54
P55
P56
P57
P58
P59
P60
P61
P62
P63
P64
P65
P66
P67
P68
P69
P70
P71
P72
P73
P74
P75
P76
P77
P78
P79
P80
P81
P82
P83
P84
P85
P86
P87
P88
P89
P90
P91
P92
P93
P94
P95
P96
P97
P98
P99
P100

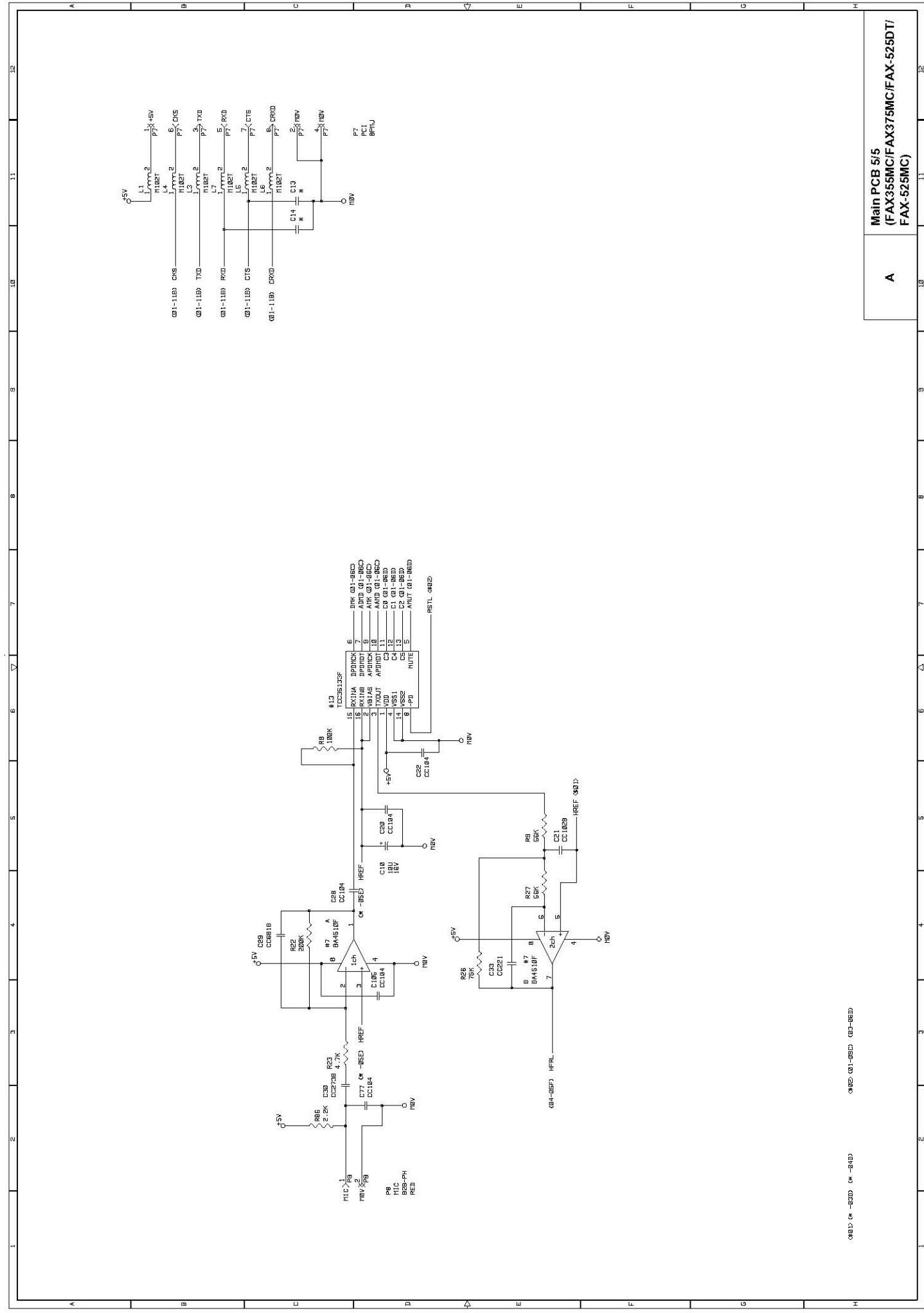

Main PCB 5/5
(FAX355MC/FAX375MC/FAX-525DT/
FAX-525MC)

A

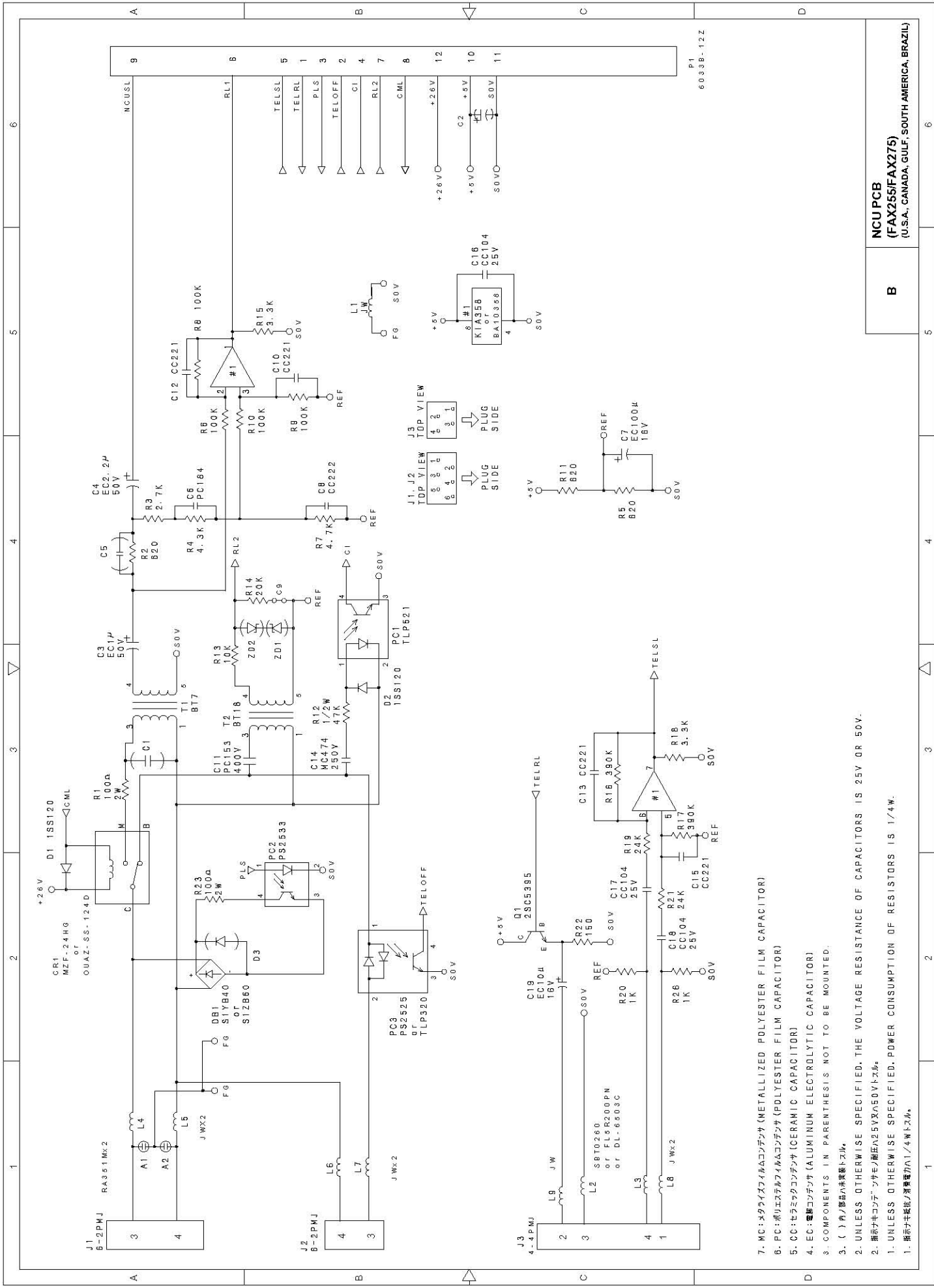

7. MC:メタライズドフィルムコンデンサ (METALLIZED POLYESTER FILM CAPACITOR)
 8. PC:ポリエチレンフィルムコンデンサ (POLYESTER FILM CAPACITOR)
 9. CC:セラミックコンデンサ (CERAMIC CAPACITOR)
 4. EC:電解コンデンサ (ALUMINUM ELECTROLYTIC CAPACITOR)
 3. () 内の部品は実装不要。
 2. UNLESS OTHERWISE SPECIFIED, THE VOLTAGE RESISTANCE OF CAPACITORS IS 25V OR 50V.
 2. 指示がキコンデ、ンサモ/極圧は25V及50Vトスル。
 1. UNLESS OTHERWISE SPECIFIED, POWER CONSUMPTION OF RESISTORS IS 1/4W.
 1. 指示がキ抵抗ノ消費電力1/4ワトスル。

B

NCU PCB
 (FAX255/FAX275)
 (U.S.A., CANADA, GULF, SOUTH AMERICA, BRAZIL)

P1
 60838-12Z

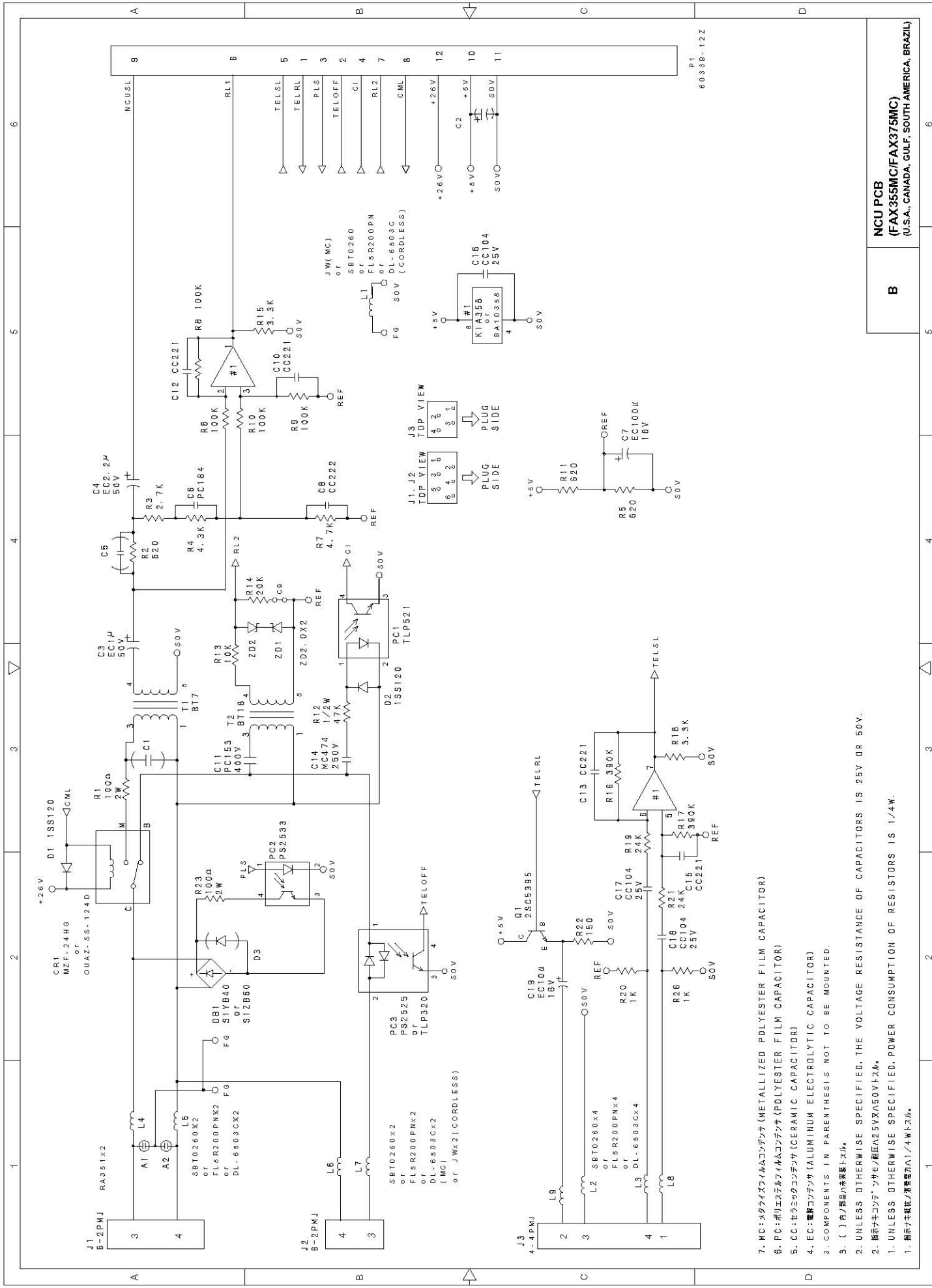

7. MC:メタライズドフィルムコンデンサ (METALLIZED POLYESTER FILM CAPACITOR)
 8. PC:ポリエチレンフィルムコンデンサ (POLYESTER FILM CAPACITOR)
 9. CC:セラミックコンデンサ (CERAMIC CAPACITOR)
 10. EC:電解コンデンサ (ALUMINUM ELECTROLYTIC CAPACITOR)
 11. COMPONENTS IN PARENTHESIS NOT TO BE MOUNTED.
 12. () 内ノ部品ハ搭載セズ。
 13. UNLESS OTHERWISE SPECIFIED, THE VOLTAGE RESISTANCE OF CAPACITORS IS 25V OR 50V.
 14. 指示ナキコンデンサモノ極性ハ25V及50Vトスル。
 15. UNLESS OTHERWISE SPECIFIED, POWER CONSUMPTION OF RESISTORS IS 1/4W.
 16. 指示ナキ抵抗ノ消費電力ハ1/4Wトスル。

NCU PCB
(FAX355MC/FAX375MC)
 (U.S.A., CANADA, GULF, SOUTH AMERICA, BRAZIL)

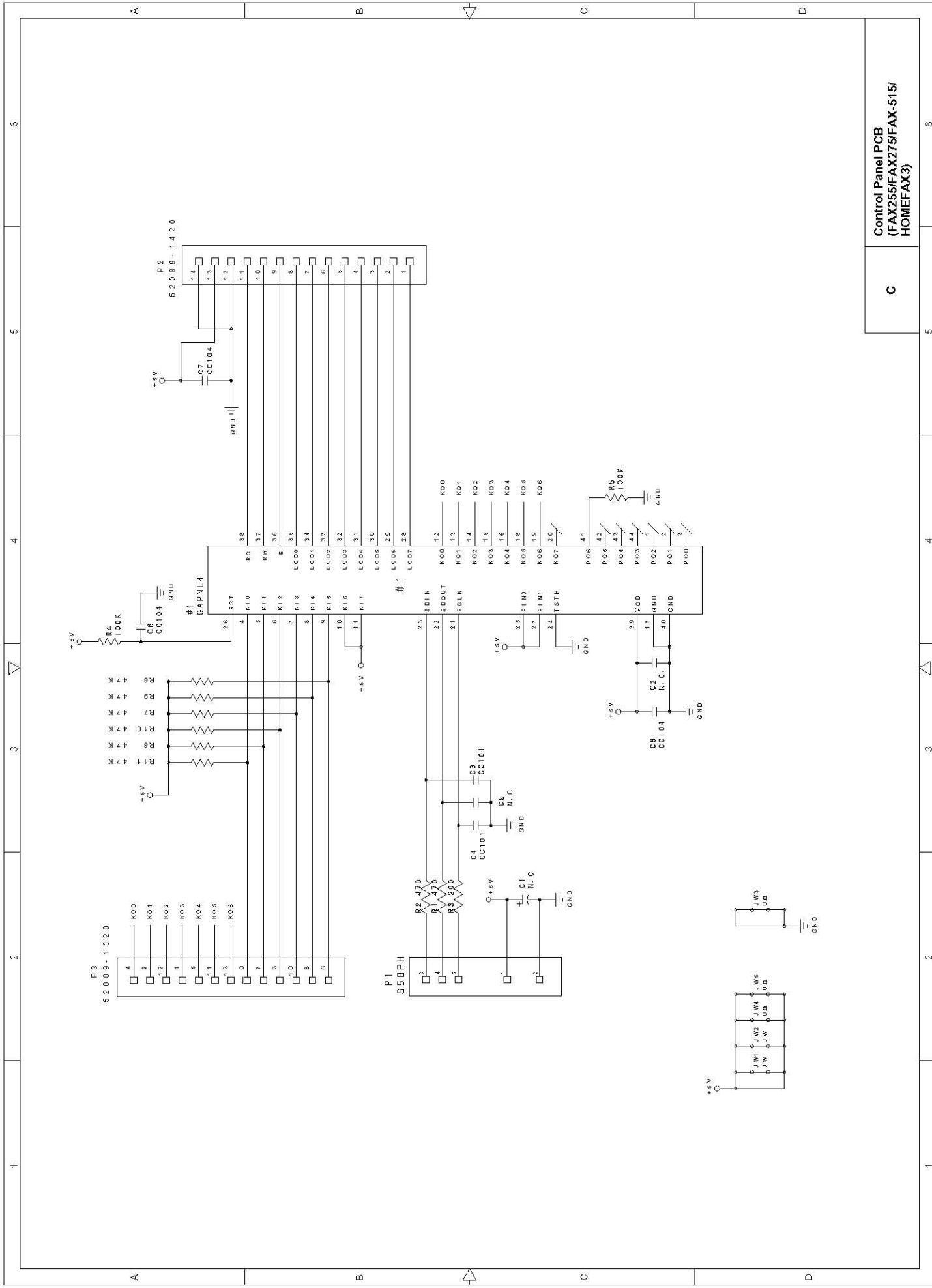

Control Panel PCB
(FAX255FAX275/FAX-515/
HOMEFAX3)

C

6

5

4

3

2

1

A

B

C

D

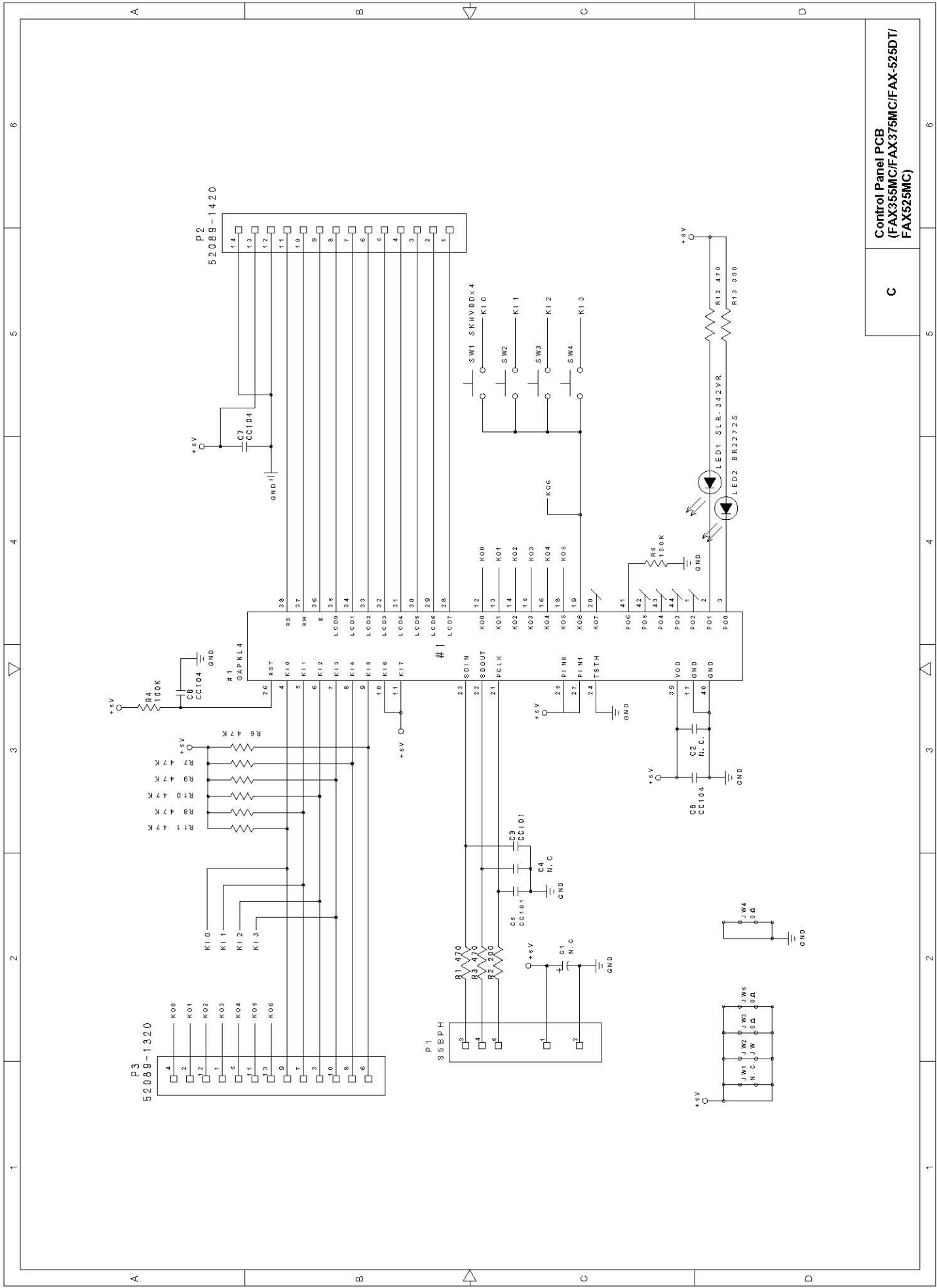

Control Panel PCB
(FAX355MC/FAX375MC/FAX-525DT/
FAX525MC)

C

6

5

4

3

2

1

A

B

C

D

6

5

4

3

2

1

A

B

C

D

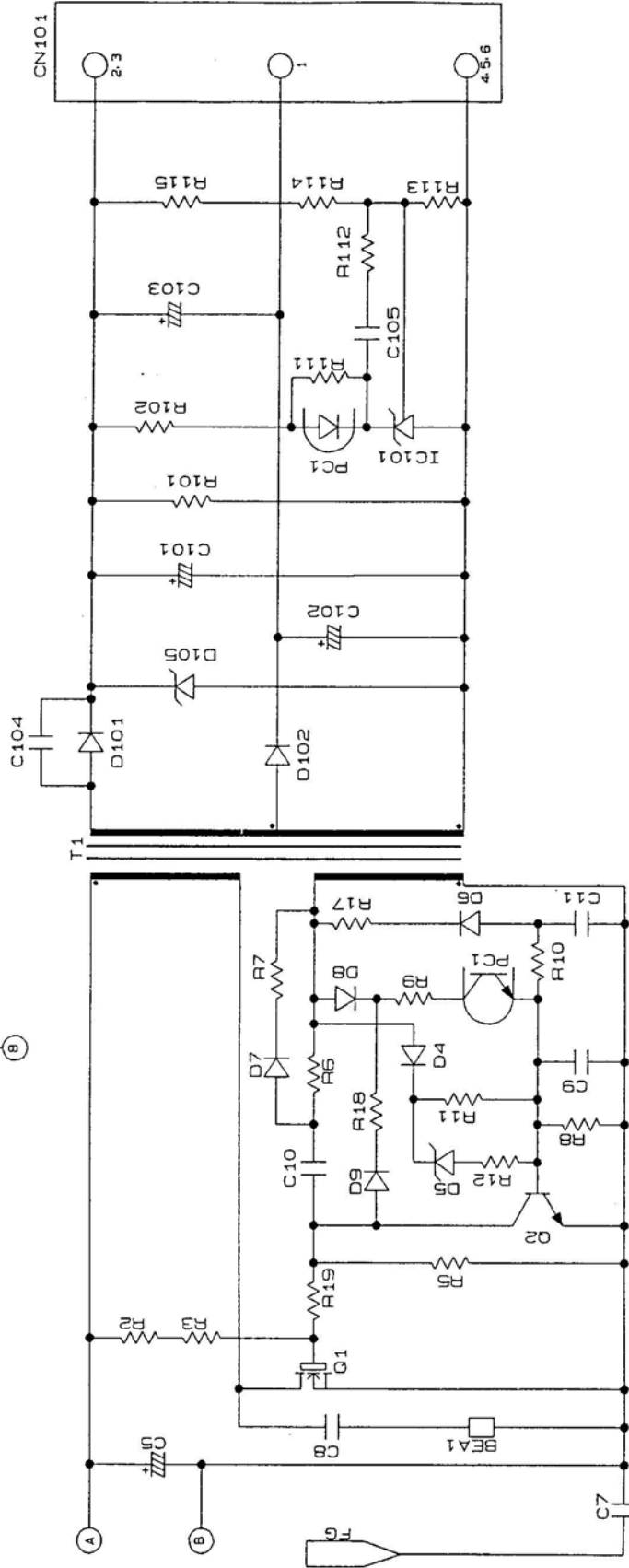
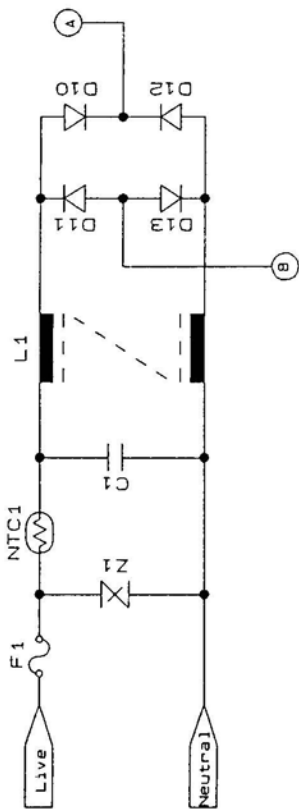

D Power Supply PCB (100-120 VAC)

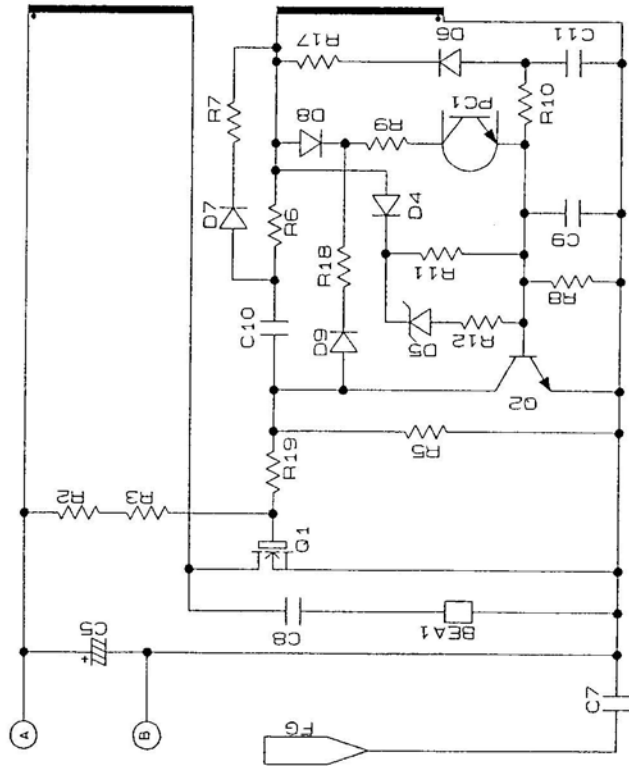
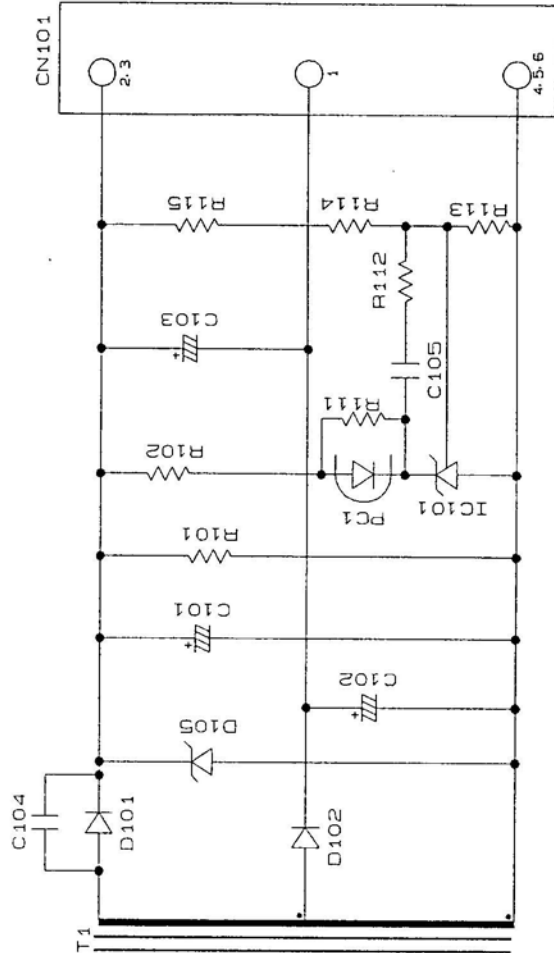
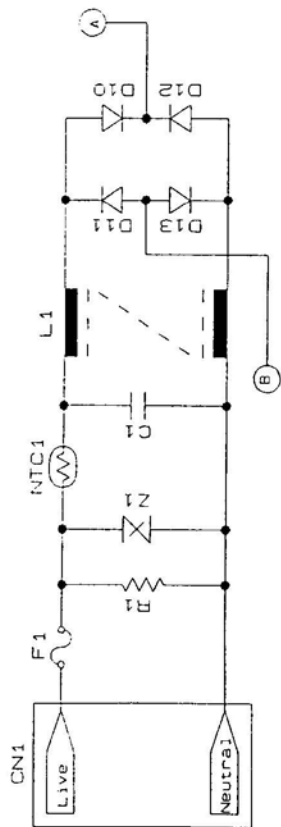

D

Power Supply PCB
(200-240 VAC)

OWNER'S
MANUAL

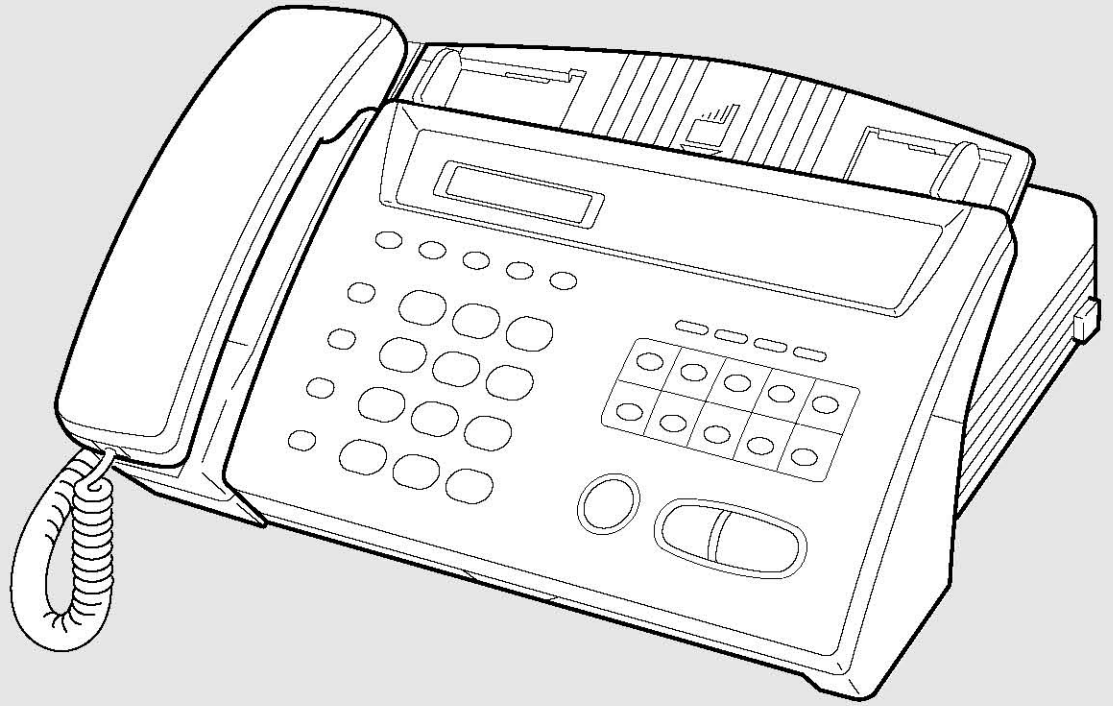

FAX 255 FAX 275

.....

brother.

If You Need to Call Customer Service

Please complete the following information for future reference:

Model Number: FAX 255, FAX 275
(Circle your model number)

Serial Number:* _____

Date of Purchase: _____

Place of Purchase: _____

***The serial number is on the back of the unit. Retain this Owner's Manual with your *sales receipt* as a permanent record of your purchase, in the event of a theft, fire or warranty service.**

Brother Numbers

Fax-Back System

Brother Customer Service has installed an easy-to-use Fax-Back System, so you can get instant answers to common technical questions and product information for all Brother products. This system is available 24 hours a day, 7 days a week. You can use the system to send faxes to any fax machine, not just the one from which you are calling.

If you can't resolve a difficulty with your fax machine using this manual, call our Fax-Back System, and follow the voice prompts to receive faxed instructions about using the system and an index of Fax-Back subjects.

USA: 1-800-521-2846
From within Canada: 1-800-681-9838

The Brother Fax-Back System number (USA Only) has been preprogrammed on One Touch key **[01]**.

Brother on the World Wide Web

You can find more information about Brother products, from product specification sheets to Frequently Asked Questions (FAQs), on the World Wide Web. Visit us at

<http://www.brother.com>

Brother Bulletin Board

Brother's Bulletin Board Numbers are

USA: 1-888-298-3616
From within Canada: 1-514-685-2040

For Customer Service

USA: 1-800-284-4329 (voice)
1-908-575-8790 (fax)
From within Canada: 1-800-853-6660 (voice)
1-514-685-4898 (fax)
From within Montreal: 1-514-685-6464 (voice)

Ordering Accessories and Supplies

For best quality results use only genuine Brother accessories, available at most Brother retailers. If you cannot find the accessory you need and you have a Visa, MasterCard, Discover, or American Express credit card, you can order accessories directly from Brother. (In the USA, you can visit us online for a complete selection of Brother accessories and supplies available for purchase.

USA: 1-888-879-3232 (voice)
1-800-947-1445 (fax)
<http://www.brothermall.com>

From within Canada: 1-800-668-2768 (voice)

Description	Item
98' Therma Plus Paper "Feels like plain paper" (2 rolls per box)	6890
98' Therma Plus Paper "Feels like plain paper" (4 rolls per box)	6840
Original Document Catch Tray	CT-70
Document support	UF6820-000
Telephone Line Cord	UG1570001 (USA) UG3565001 (CANADA)
Telephone Handset	UF6857004 (FAX 255) UF6857008 (FAX 275)
Handset Curled Cord	UG3543004 (FAX 255) UG3543003 (FAX 275)
Owner's Manual for FAX 255/275	UF0831001

Notice – Disclaimer of Warranties (For USA and Canada)

BROTHER'S LICENSOR(S), AND THEIR DIRECTORS, OFFICERS, EMPLOYEES OR AGENTS (COLLECTIVELY BROTHER'S LICENSOR) MAKE NO WARRANTIES, EXPRESS OR IMPLIED, INCLUDING WITHOUT LIMITATION THE IMPLIED WARRANTIES OF MERCHANTABILITY AND FITNESS FOR A PARTICULAR PURPOSE, REGARDING THE SOFTWARE. BROTHER'S LICENSOR(S) DOES NOT WARRANT, GUARANTEE OR MAKE ANY REPRESENTATIONS REGARDING THE USE OR THE RESULTS OF THE USE OF THE SOFTWARE IN TERMS OF ITS CORRECTNESS, ACCURACY, RELIABILITY, CURRENTNESS OR OTHERWISE. THE ENTIRE RISK AS TO THE RESULTS AND PERFORMANCE OF THE SOFTWARE IS ASSUMED BY YOU. THE EXCLUSION OF IMPLIED WARRANTIES IS NOT PERMITTED BY SOME STATES IN THE USA AND SOME PROVINCES IN CANADA. THE ABOVE EXCLUSION MAY NOT APPLY TO YOU.

IN NO EVENT WILL BROTHER'S LICENSOR(S) BE LIABLE TO YOU FOR ANY CONSEQUENTIAL, INCIDENTAL OR INDIRECT DAMAGES (INCLUDING DAMAGES FOR LOSS OF BUSINESS PROFITS, BUSINESS INTERRUPTION, LOSS OF BUSINESS INFORMATION, AND THE LIKE) ARISING OUT OF THE USE OR INABILITY TO USE THE SOFTWARE EVEN IF BROTHER'S LICENSOR HAS BEEN ADVISED OF THE POSSIBILITY OF SUCH DAMAGES. BECAUSE SOME STATES IN THE USA AND SOME PROVINCES IN CANADA DO NOT ALLOW THE EXCLUSION OR LIMITATION OF LIABILITY FOR CONSEQUENTIAL OR INCIDENTAL DAMAGES, THE ABOVE LIMITATIONS MAY NOT APPLY TO YOU. IN ANY EVENT BROTHER'S LICENSOR'S LIABILITY TO YOU FOR ACTUAL DAMAGES FROM ANY CAUSE WHATSOEVER, AND REGARDLESS OF THE FORM OF THE ACTION (WHETHER IN CONTRACT, TORT (INCLUDING NEGLIGENCE), PRODUCT LIABILITY OR OTHERWISE), WILL BE LIMITED TO \$50.

BROTHER FACSIMILE 90 DAY REPLACEMENT WARRANTY A LIMITED WARRANTY (For USA Only)

This warranty gives you certain rights and you may also have other rights that may vary from state to state.

This warranty is given only to the end-use purchaser of the accompanying product (referred to in this warranty as "this Product").

What is covered: Brother warrants to you for the Warranty Period that there are no defects in the materials, workmanship or Year 2000 compliance of this Product. The "Warranty Period" is 90 days from the date you purchased this product.

What is NOT covered: This warranty is VOID — that is, this Product has no warranty — if: (1) you did not purchase this Product from an authorized Brother reseller within the United States, (2) this Product has been serviced, modified or tampered with by anyone other than an Authorized Service Representative of Brother, (3) the serial number has been modified, defaced or removed from this Product, (4) this Product has been abused or damaged, or (5) non Brother®-brand or non Brother approved parts, supplies, or other accessories have been used with this Product.

What to do if you think your Product is defective:

Call our Customer Service Hotline at 1-800-284-4329, or if you suspect a defect in materials or workmanship in this Product, you can report it to a Brother Authorized Service Center. During the Warranty Period, supply Brother's representative with a copy of your dated bill of sale showing that this Product was purchased within the United States. For the name of your Brother Authorized Service Center, call 1-800-521-2846. After contacting the Brother Authorized Service Center, you may be required to deliver or send the Product properly packaged, freight prepaid, to the Authorized Service Center together with a photocopy of your bill of sale.

What Brother will do: Brother (or its Authorized Service Center) will evaluate your report of a possible defect to determine whether a defect exists, and if it does exist, Brother (or its Authorized Service Center) will repair or (at Brother's option) replace the Product with a product that performs the same functions and performs as well as the original Product. Brother reserves the right to supply refurbished or remanufactured replacement products provided that the replacement products conform to the manufacturer's specifications for new products. The repaired or replacement product will be returned to you at no cost.

Exchange Service:

Exchange service will expedite, in most instances by the next business day, the exchange of your non working Product with a supply refurbished or remanufactured product that conform to the manufacturer's specifications for new products. The supply refurbished or remanufactured Product you receive will be covered by the balance of the limited warranty period remaining on the original Product, plus an additional thirty (30) days. You will keep the replacement Product that is sent to you and must return (or be billed up to the cost of a new product) your original non working product, which shall become the property of Brother. You must call Brother Customer Service and if the representative cannot correct the product's malfunction over the telephone and you elect the exchange service, you must provide information pertaining to this Product and you must also provide a valid major credit card number. Your credit card will be charged up to the cost of a new Product if: (i) you do not return your original Product to Brother within five (5) business days; (ii) the malfunctions of your original Product are not covered by the limited warranty; (iii) the proper packaging instructions are not followed and has caused damage to the product; or (iv) the warranty period on your original

**BROTHER FACSIMILE 90 DAY REPLACEMENT WARRANTY
A LIMITED WARRANTY
(For USA Only)**

Product has expired or has not been sufficiently validated with a copy of the proof of purchase (bill of sale). The Brother Customer Service Representative will ship the exchange Product with return instructions and prepaid return airbill. Follow the return instructions. You must return the original Product in the same shipping carton in which the exchanged Product was received and include a copy of proof of purchase (bill of sale). Retain your original accessory items and a copy of the return airbill, signed by the courier.

Limitations:

Repair or replacement as described above is your sole and exclusive (that is, your only) remedy if this Product is defective. Brother is not responsible for damage to or loss of any equipment, media, programs or data related to the use of this Product. Except for that repair or replacement, *Brother shall not be liable for any direct, indirect, incidental or consequential damages or specific relief. Because some states do not allow the exclusion or limitation of consequential or incidental damages, the above limitation may not apply to you.*

THIS WARRANTY IS GIVEN IN LIEU OF ALL OTHER WARRANTIES, WRITTEN OR ORAL, WHETHER EXPRESSED BY AFFIRMATION, PROMISE, DESCRIPTION, DRAWING, MODEL OR SAMPLE. ANY AND ALL WARRANTIES OTHER THAN THIS ONE, WHETHER EXPRESS OR IMPLIED, INCLUDING IMPLIED WARRANTIES OF MERCHANTABILITY AND FITNESS FOR A PARTICULAR PURPOSE, ARE HEREBY DISCLAIMED.

This Limited Warranty is the only warranty that Brother is giving for this Product. It is the *final expression and the exclusive and only statement* of Brother's obligations to you. It replaces all other agreements and understandings that you may have with Brother or its representatives.

This Limited Warranty (and Brother's obligation to you) may not be changed in any way unless you and Brother sign the same piece of paper in which we (1) refer to this Product and your bill of sale date, (2) describe the change to this warranty and (3) agree to make that change.

Product Support: Toll-free customer service and technical support is available for hardware operational assistance at 1-800-284-4329. At any time, free technical support in the form of Frequently Asked Questions, troubleshooting tips and service center locator is available through our fax back system at 1-800-521-2846 or Brother's Internet Web Site (www.brother.com).

**BROTHER INTERNATIONAL CORPORATION
100 SOMERSET CORPORATE BLVD.
BRIDGEWATER, NEW JERSEY 08807-0911**

Please record your model and serial number and your date and location of Purchase below for your records. Keep this information with your proof of purchase (bill of sale) in case your Product is lost, stolen or requires service.

Model # _____

Serial # _____

Date of purchase: _____

Store where purchased: _____

Location of store: _____

Important: We recommend that you keep all original packing materials, in the event that you ship this product.

BROTHER MULTIFUNCTION CENTER/FACSIMILE MACHINE LIMITED WARRANTY (For Canada Only)

Pursuant to this limited warranty of 1 year from the date of purchase for labour and parts, Brother International Corporation (Canada) Ltd. ("Brother"), or its Authorized Service Centers, will repair this MFC/Facsimile machine free of charge if defective in material or workmanship. This Limited Warranty does not include cleaning, consumables (including, without limitation, print cartridges, print head, toner and drum) or damage caused by accident, neglect, misuse or improper installation or operation, any damage caused from service, maintenance, modifications, or tampering by anyone other than a Brother Authorized Service Representative, or from the use of supplies or consumable items that are non-Brother products. Operation of the MFC/Facsimile machine in excess of the specifications or with the Serial Number or Rating Label removed shall be deemed abuse and all repairs thereafter shall be the sole liability of the end-user/purchaser. In order to obtain warranty service, the MFC/Facsimile machine must be delivered or shipped freight prepaid by the end user/purchaser to a "Brother" Authorized Service Center, together with your Proof of Purchase in the form of a Sales Receipt.

For laser products: Failure to remove the Toner Cartridge (and Toner Drum Unit on applicable models) during shipping will cause severe damage to the MFC/Facsimile and will VOID the Warranty. (Refer to your Operation Manual for proper packaging.)

For ink-jet products: Do not remove the ink cartridges during shipping. Damage to your print head resulting from packing without the ink cartridges will VOID your warranty. (Refer to your Operation Manual for proper packaging.)

BROTHER DISCLAIMS ALL OTHER WARRANTIES EXPRESSED OR IMPLIED INCLUDING, WITHOUT LIMITATION, ANY IMPLIED WARRANTIES OF MERCHANTABILITY OR FITNESS FOR A PARTICULAR PURPOSE, EXCEPT TO THE EXTENT THAT ANY WARRANTIES IMPLIED BY LAW CANNOT BE VALIDLY WAIVED.

No oral or written information, advice or representation provided by Brother, its Authorized Service Centers, Distributors, Dealers, Agents or employees, shall create another warranty or modify this warranty. This warranty states Brother's entire liability and your exclusive remedy against Brother for any failure of the MFC/Facsimile machine to operate properly.

Neither Brother nor anyone else involved in the development, production, or delivery of this MFC/Facsimile machine shall be liable for any indirect, incidental, special, consequential, exemplary, or punitive damages, including lost profits, arising from the use of or inability to use the product, even if advised by the end user/purchaser of the possibility of such damages. Since some Provinces do not allow the above limitation of liability, such limitation may not apply to you.

This Limited Warranty gives you specific legal rights and you may also have other rights which vary from Province to Province.

Warranty Service is available at Brother Authorized Service Centers throughout Canada. For Technical Support or for the name and location of your nearest Authorized Service Center call 1-800-853-6660. Within Montreal, please call 685-6464. Internet support: support@brother.ca or browse Brother's Web Site: www.brother.com

Brother International Corporation (Canada) Ltd.
1 Rue Hôtel de Ville
Dollard-Des-Ormeaux, QC H9B 3H6

Year 2000 Compliant

Brother is addressing the Year 2000 related issues for all Brother fax machines and multi-function centers. Our focus is to ensure that our bundled third party software will continue to properly process date/time data after January 1, 2000.

Brother fax machines and multi-function centers will function properly after January 1, 2000, *provided that* all non-Brother hardware, software and firmware used by our customers in connection or combination with Brother fax machines, and bundled software, accurately exchange date data with the Brother products.

Please continue to check our Web page for updates at <http://www.brother.com>. All remedies will be provided to individual customers via software patches through software download or from Brother Customer Service.

Table of Contents



1 Introduction

- Using This Manual 1
 - Finding Information 1
- Test Sheet Procedures (for USA only) 2
- About Fax Machines 2
 - Fax Tones and Handshake 2
- Control Panel Overview 4
 - FAX 255 and FAX 275 4

2 Set Up and Connections

- Caution 5
- Packing List 6
- Choosing a Location 7
- Assembly 7
 - Load the recording paper 7
 - About Brother Paper 9
 - Connect the handset 9
 - Connect the power cord 10
 - Connect the telephone line 10
 - Attach the document support 10
 - Special Line Considerations 11
 - Roll Over Phone Lines 11
 - Two-Line Phone System 11
 - Converting Telephone Wall Outlets 11
 - Installing fax machine, External Two-Line TAD,
and Two-Line Telephone 12
 - Multi-Line Connections (PBX) 13
 - If you are installing the fax machine to work with a PBX: 14
 - Custom Features on Your Phone Line 14
 - Connecting an External Telephone Answering Device (TAD) 14
 - Sequence 14
 - Connections 15
 - Outgoing Message (OGM) 16
 - Connecting an External Telephone 16

3 On-Screen Programming

User-Friendly Programming	17
Function Mode	17
Alternating Displays	18
Function Selection Table	19

4 Initial Setup

Getting Started	23
Setting Dialing Mode (Tone/Pulse)	23
Setting Date and Time	23
Setting Station ID	24
Entering Text	25
Inserting Spaces	25
Making Corrections	25
Repeating Letters	25
Special Characters and Symbols	25
Setting Up Your Area Code (For USA Only)	26
Setting Beeper Volume	27
Setting the Handset Volume	27
Setting Volume Amplify	28
Setting the Speaker Volume	28
Setting the Ring Volume	28
Memory Storage	28

5 Setup Receive

Basic Receiving Operations	29
Select Answer Mode	29
To select or change your Answer Mode	30
Setting Ring Delay	30
Setting F/T Ring Time	31
Easy Receive	31
Advanced Receiving Operations	32
Operation from Extension Telephone	32
For FAX/TEL Mode Only	33
Changing Remote Codes	33
To change Remote Codes	33
Polling	34
Setting Up Polling Receive	34

6 Setup Send

Before You Begin	35
ADF (Automatic Document Feeder)	36
Resolution	36
Contrast	36
Manual Transmission	37
Automatic Transmission	37
Manual and Automatic Fax Redial	37

7 Setup Auto Dial Numbers

Advanced Sending Operations	38
Overseas Mode	38
Delayed FAX	38
Next-Fax Reservation (For FAX 275 Only)	39
Multiple Resolution Transmission	40
Setting Up Polling Transmit	40
Canceling a Scheduled Job	41
Interrupting Delayed Fax and Polling Transmit Jobs	41

8 Telephone Operation

Storing Numbers for Easy Dialing	43
Storing One Touch Dial Numbers	43
Access Codes and Credit Card Numbers	44
Storing Speed Dial Numbers	45
Changing One Touch and Speed Dial Numbers	46
Dialing Options	47
Manual Dialing	47
One Touch Dialing	48
Speed Dialing	48
Hold	48
Pause	49
Tone/Pulse	49
Searching Telephone Index	49

9 Telephone Service

Custom Features	51
Distinctive Ring	51
Registering the Distinctive Ring Pattern	52
Caller ID	53
Caller ID Log	53
Printing the Caller ID Log	53
Viewing the Caller ID Log	54
Returning a Call from the Log	55
Registering a Caller ID Number	56

10 Making Copies

Copy Functions	57
-----------------------------	----

11 Printing Reports

FAX Settings	59
To Print a Report	60
Transmission Verification (Xmit) Report	60
Using the Trans. Verify Key	60

**Important
Information**

Standard Telephone and FCC Notices	61
These notices are in effect on models sold and used in the United States only.	64
Federal Communications Commission Compliance Notice (For USA Only)	63
Industry Canada Compliance Statement (For Canada Only)	63
Important Safety Instructions	64
Compilation and Publication Notice	66
Trademarks	66

**Troubleshooting
and Maintenance**

Troubleshooting	67
Fax-Back System	67
Brother on the World Wide Web	67
Brother Bulletin Board	67
Error Messages	68
Recording Paper Jam	71
If You Are Having Difficulty with Your Fax Machine	72
Printing or Receiving Faxes	72
Condensed Print and Horizontal Streaks; Top and Bottom of Sentences Cut Off	72
Enabling/Disabling Anti-Curl Check Sheet (ACS)	72
Vertical Black Lines When Receiving	72
Phone Line or Connections	72
Fax Machine Does Not Answer When Called	72
No Dial Tone on the Handset	73
Sending Faxes	73
Poor Transmitting Quality	73
Dialing Does Not Work	73
Vertical Black Lines When Sending	73
Handling Incoming Calls	73
Double Ring in FAX/TEL Mode	73
Transferring a Call to the Fax Machine	74
Fax Machine “Hears” Voice as CNG Tone	74
Transmission Verification Report Prints “Result: NG”	74
Custom Features on a Single Line	74
For Customer Service	74

Specifications

Specifications	75
Glossary	77
Index	79

1 Introduction

Using This Manual

Thank you for purchasing a Brother fax machine. This fax machine has been designed to be simple to use, with LCD screen prompts to guide you through functions. However, you can use your fax machine to its fullest potential by taking a few minutes to read this manual.



Additionally, your fax machine has a Help Key. Press **Help** to print a list of basic operational steps and functions.

Finding Information

All chapter headings and subheadings are listed in the Table of Contents. You will be able to find information about a specific feature or function by checking the Index at the back of this manual. Also, throughout this manual, you'll see special symbols alerting you to important information, cross-references, and warnings. Illustrations of some screen displays also help you choose the correct key-presses.

Test Sheet Procedures (for USA only)

*See
Setting
Station ID
p. 24*

After programming your Station ID, please fill out the TEST SHEET included with your fax machine and fax it to Brother's Automated Fax Response System as your first transmission. This will verify that your fax machine is properly installed.

When this document is received a confirmation sheet will be sent back to your machine. To get a response, be sure to set up your Station ID.

USA 1-908-685-9283 (fax)

About Fax Machines

If you're a first-time fax machine user, fax operation might seem a little mysterious. You'll soon get used to the unusual fax tones on your phone line, and be able to send and receive faxes easily.

Fax Tones and Handshake

When someone is sending a fax, the fax machine sends fax calling tones, (CNG tones) — soft, intermittent beeps at 4-second intervals. You'll hear them when you dial and press **[Start]**, and they continue for about 40 seconds after dialing. During that time, the sending machine must begin the "handshake" with the receiving machine. Each time you use automatic procedures to send a fax, you are sending CNG tones over the phone line. You'll soon learn to listen for these soft beeps each time you answer a phone on your fax line, so you know if you are receiving a fax message.

The receiving fax responds with fax receiving tones — loud, chirping sounds. A receiving fax chirps for about 40 seconds over the phone line, and the screen displays RECEIVE. If your fax machine is set to the FAX ONLY Mode, it will answer every call automatically with fax receiving tones. Even if the other party hangs up, your fax machine continues to send the "chirps" for about 40 seconds, and the screen continues to display RECEIVE. To cancel the receiving mode, press **[Stop]**.

When your fax machine answers in FAX/TEL Mode, the fax machine listens for CNG tones and then responds with receiving tones.

The fax “handshake” is the time in which the sending machine’s CNG tones and the receiving machines “chirps” overlap. This must be for at least 2 to 4 seconds, so the machines can understand how each is sending and receiving the fax. The handshake cannot begin until the call is answered, and the CNG tones only last for about 40 seconds after the number is dialed. Therefore, it’s important for the receiving machine to answer the call in as few rings as possible.



When you have an external telephone answering device (TAD) on your fax line, your TAD will determine the number of rings before the call is answered. Pay special attention to the directions in the Installation chapter for connecting a TAD to your fax machine.

Control Panel Overview

FAX 255 and FAX 275

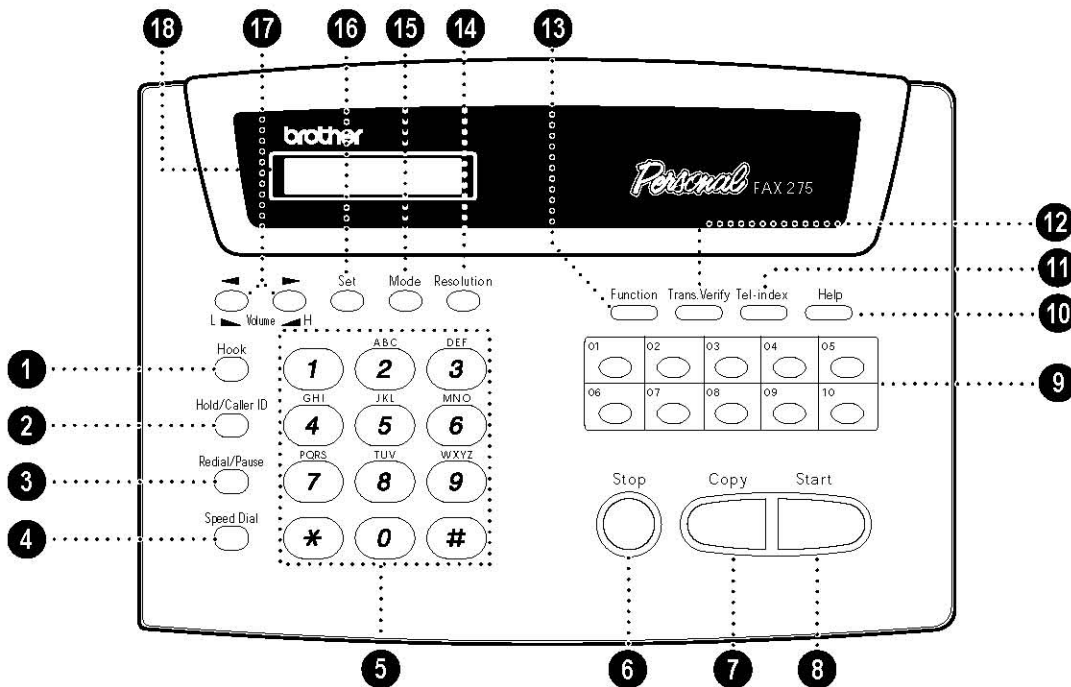

1 Hook
Lets you dial telephone and fax numbers without lifting the handset.

2 Hold/Caller ID
Lets you put calls on hold. Also, lets you view or print the Caller ID list.

3 Redial / Pause
Re-dials the last number called. Also inserts a pause in autodial numbers.

4 Speed Dial
Lets you dial stored phone numbers by pressing a two-digit number.

5 Dial Pad
Dials phone and fax numbers, and can be used as a keyboard for entering information into the fax machine.

6 Stop
Stops a fax, cancels an operation or exits from function mode.

7 Copy
Makes a copy.

8 Start
Starts an operation, such as sending a fax.

9 One Touch Dial Keys
These ten keys give you instant access to previously stored phone numbers.

10 Help
Prints a quick reference Help List.

11 Tel-index
Lets you look up numbers stored in the dialing memory.

12 Trans. Verify
Lets you print the Transmission Verification Report for your last transmission.

13 Function
Lets you access the function and programming mode.

14 Resolution
Sets the resolution when you send a fax or make a copy.

15 Mode
Use to select how fax machine will handle incoming calls.

16 Set
Stores a function setting into the fax machine.

17 ◀ (Left Arrow)
▶ (Right Arrow)

Volume
Moves the LCD cursor to the left or right. Adjusts speaker, ring and handset volume.

18 Liquid Crystal Display
Displays messages to help you set up and operate your fax machine.

Set Up and Connections

Caution

- 1 Never install telephone wiring during a lightning storm.
- 2 We recommend that this product be used with a surge protection device to protect the product against lightning storms.
- 3 Never install a telephone jack in a wet location unless the jack is specifically designed for a wet location.
- 4 Never touch telephone wires or terminals that are not insulated unless the telephone line has been disconnected at the network interface.
- 5 Use caution when installing or modifying telephone lines.
- 6 Avoid using a telephone (other than a cordless type) during an electrical storm. There may be a remote risk of electric shock from lightning.
- 7 Do not use the telephone to report a gas leak in the vicinity of the leak.
- 8 For PLUGGABLE EQUIPMENT, the socket-outlet should be installed near the equipment and should be easily accessible.

Packing List

Make sure you have the following items:

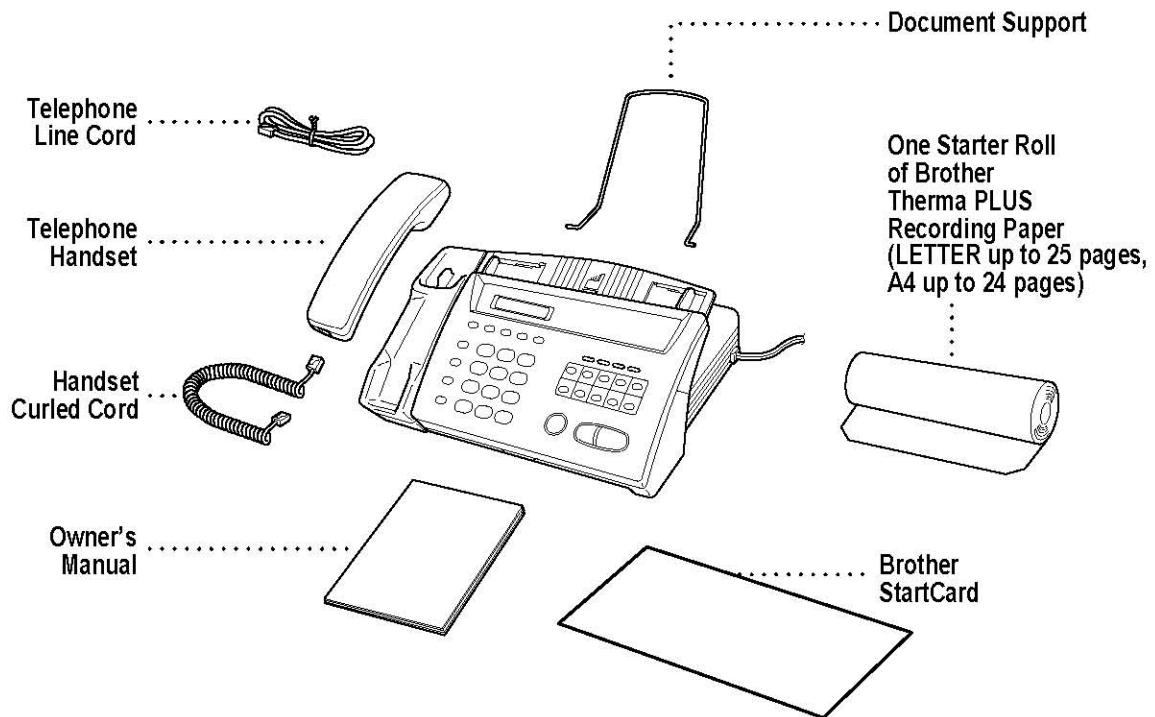

NOTICE: If an item is missing, call Brother Customer Service at 1-800-284-4329 (USA), 1-800-853-6660 (from within Canada) or 1-514-685-6464 (from within Montreal). See Ordering Accessories and Supplies on page ii for the correct item numbers.

Whenever you transport the fax machine, use the packing materials that came with your machine. If you do not pack the fax machine correctly, you may void your warranty.

Choosing a Location

Place your fax machine on a flat, stable surface, such as a desk. Select a place that is free of vibration and shocks. Locate the fax machine near a telephone jack and a standard, grounded power outlet.



Avoid placing your machine in a high-traffic area. Do not place near heaters, air conditioners, water, chemicals or refrigerators. Do not expose the fax machine to direct sunlight, excessive heat, moisture or dust. Do not connect your machine to electrical outlets controlled by wall switches or automatic timers. Disruption of power can wipe out information in the unit's memory. Do not connect your machine to electrical outlets on the same circuit as large appliances or other equipment that might disrupt the power supply. Avoid interference sources, such as speakers or the base units of cordless phones.

Assembly

Load the recording paper

- 1 Open the cover by placing your finger in the groove under the cover and lifting up.



- 2 Pull up the blue release lever so you can remove the three protective sheets (initial set up) or any paper remaining in the machine from the last roll.

- 3** Unwrap the new recording paper roll and insert it into the paper bin, with the paper feeding from the bottom of the roll.

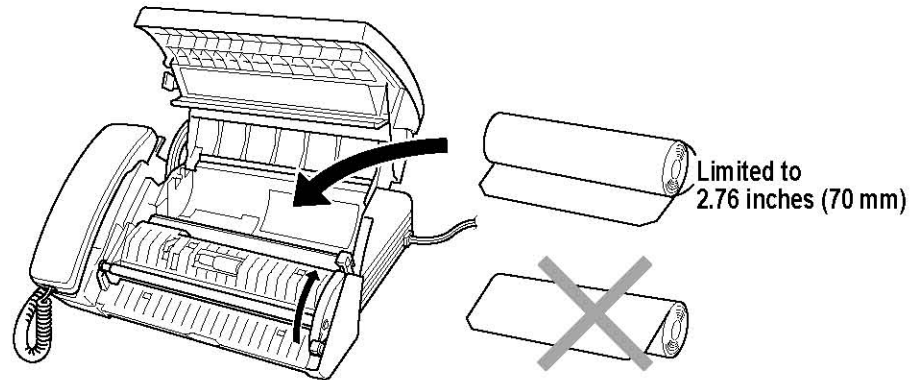

- 4** Raise the paper enough to pass it over the  until it feeds out the front of the machine. Make sure there is no slack.

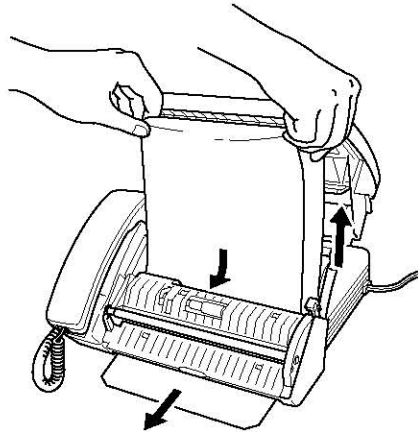

- 5** Pull down the blue lever and close the cover.

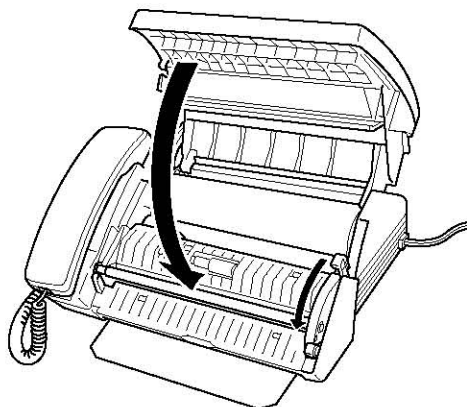

About Brother Paper

For the best print quality, use Brother Therma Plus Paper, Item Numbers 6890 (two 98' rolls) or 6840 (four 98' rolls). Therma Plus paper is thicker, like plain paper, and produces the best print quality.



The recording paper roll size for your fax machine is limited to a diameter of 2.76 inches (70 mm). You can use a 164' roll of thinner thermal paper as long as it meets these requirements.

Connect the handset

Connect the curled handset cord to the bottom of the handset and the side of the fax machine.

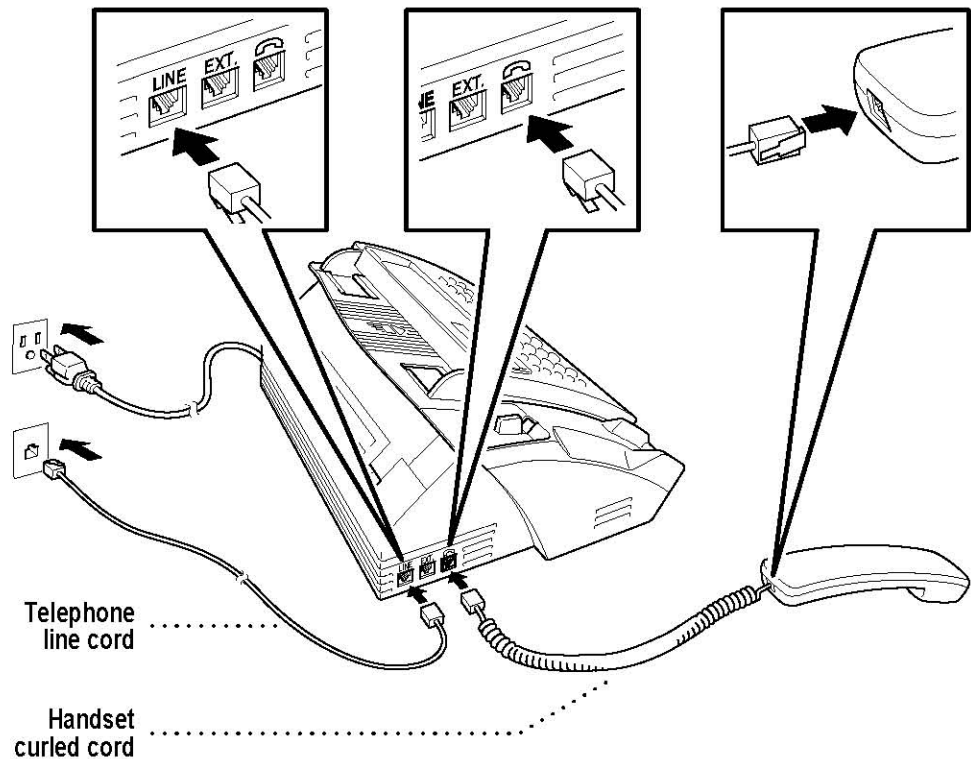



Connect the power cord

When you connect the power, the screen displays 01/01 00:00 FAX.

NOTICE:

- 1) This fax must be grounded using a three-prong plug.
- 2) Since the fax machine is grounded through the power outlet, you can protect yourself from potentially hazardous electrical conditions on the telephone network by keeping the power to your machine on when you connect it to a telephone line. Similarly, you can protect yourself when you want to move your machine, by disconnecting the telephone line first, and then the power cord.
- 3) Lightning and power surges can damage this product! We recommend that you use a quality surge protection device on the AC power line as well as on the telephone line, or unplug the telephone line and electrical cords during a lightning storm.

Connect the telephone line

Connect one end of the telephone line cord to the jack labeled **LINE** on the left side of the fax machine. Connect the other end to a modular wall jack.

Attach the document support

Attach the document support as shown in the illustration below.

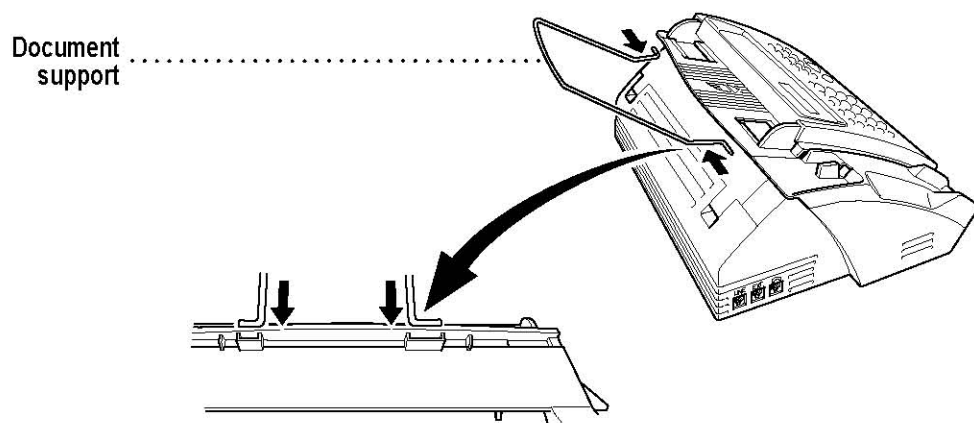

Special Line Considerations

Roll Over Phone Lines

A roll over phone system is a group of two or more separate telephone lines that pass incoming calls to each other if they are busy. The calls are usually passed down or “rolled over” to the next available phone line in a preset order.

Your fax machine can work in a roll over system as long as it is the last number in the sequence, so the call cannot roll away. Do not put the fax machine on any of the other numbers; when the other lines are busy and a second fax call is received, the fax call is transferred to a line that does not have a fax machine. Your fax machine will work best on a dedicated line.

Two-Line Phone System

A two-line phone system is nothing more than two separate phone numbers on the same wall outlet. The two phone numbers can be on separate jacks (RJ11) or combined into one jack (RJ14). Your fax machine must be plugged into an RJ11 jack. RJ11 and RJ14 jacks may be equal in size and appearance and both may contain four wires (black, red, green, yellow). To test the type of jack, plug in a two-line phone and see if it can access both lines. If it can, you must separate the line for your fax machine.

Converting Telephone Wall Outlets

There are three ways to convert to an RJ11 receptacle. The first two ways may require assistance from the telephone company. You can change the wall outlets from one RJ14 jack to two RJ11 jacks. Or, you can have an RJ11 wall outlet installed and slave or jump one of the phone numbers to it.

The third way is the easiest: Buy a triplex adapter. You can plug a triplex adapter into an RJ14 outlet. It separates the wires into two separate RJ11 jacks (Line 1, Line 2) and a third RJ14 jack (Lines 1 and 2). If your fax machine is on Line 1, plug the fax machine into L1 on the triplex adapter. If your fax machine is on Line 2, plug it into L2 on the triplex adapter.

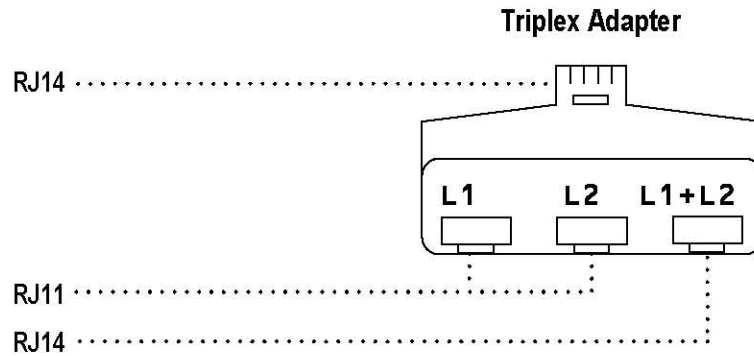

Installing fax machine, External Two-Line TAD, and Two-Line Telephone

When you are installing an external two-line telephone answering device (TAD) and a two-line telephone, your fax machine must be isolated on one line at both the wall jack and at the TAD. *The most common connection is to put the fax machine on Line 2, which is our assumption in the following steps.* The back of the two-line TAD must have two telephone jacks: one labeled L1 or L1/L2, and the other labeled L2. You will need at least three telephone line cords, the one that came with your fax machine and two for your external two-line TAD. You will need a fourth line cord if you add a two-line telephone.

- 1** Place the two-line TAD and the two-line telephone next to your fax machine.
- 2** Plug one end of the telephone line cord for your fax machine into the L2 jack of the triplex adapter. Plug the other end into the LINE jack on the left side of the fax machine.
- 3** Plug one end of the first telephone line cord for your TAD into the L1 jack of the triplex adapter. Plug the other end into the L1 or L1/L2 jack of the two-line TAD.

- 4 Plug one end of the second telephone line cord for your TAD into the L2 jack of the two-line TAD. Plug the other end into the EXT. jack on the left side of the fax machine.

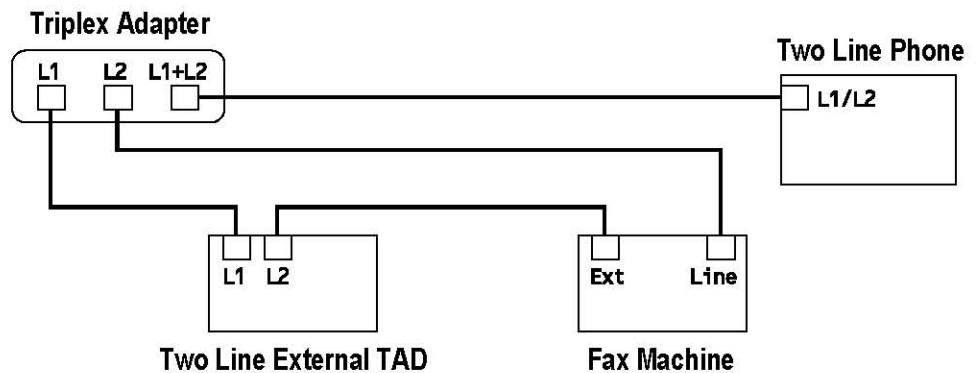

You can keep two-line telephones on other wall outlets as always. There are two ways to add a two-line telephone to the fax machine's wall outlet. You can plug the telephone line cord from the two-line telephone into the L1+L2 jack of the triplex adapter. Or, you can plug the two-line telephone into the TEL jack of the two-line TAD.

Multi-Line Connections (PBX)

Most offices use a central telephone system. While it is often relatively simple to connect the fax machine to a key system or a PBX (Private Branch Exchange), we suggest that you contact the company that installed your telephone system and ask them to connect the fax machine for you. It is advisable to have a separate line for the fax machine. You can then leave the fax machine in FAX ONLY Mode to receive faxes any time of day or night.

See
Easy Receive
p. 31



If the fax machine is to be connected to a multi-line system, ask your installer to connect the unit to the last line on the system. This prevents the unit from being activated each time a telephone call is received.

As with all fax units, this machine must be connected to a two wire system. If your line has more than two wires, proper connection of the fax machine cannot be made.

If you are installing the fax machine to work with a PBX:

- 1** It is not guaranteed that the unit will operate correctly under all circumstances with a PBX. Any cases of difficulty should be reported first to the company that handles your PBX.
- 2** If all incoming calls will be answered by a switchboard operator, it is recommended that the Answer Mode be set to MANUAL. All incoming calls should initially be regarded as telephone calls.
- 3** The unit may be used with either pulse or tone dialing telephone service.

Custom Features on Your Phone Line

If you have telephone services (offered by your telephone company) on your phone line, please see Telephone Service, chapter 9.

Connecting an External Telephone Answering Device (TAD)

Sequence

You might choose to connect an additional answering system. When you have an **external** TAD on the same telephone line as the fax machine, the TAD answers all calls. The fax machine “listens” for fax calling (CNG) tones. If it hears them, the fax machine takes over the call and receives the fax. If it doesn’t hear CNG tones, the fax machine lets the TAD continue playing your outgoing message so your caller can leave you a voice message.

The TAD must answer within four rings (the recommended setting is two rings). The fax machine cannot hear CNG tones until the TAD has answered the call, and with four rings there are only 8–10 seconds of CNG tones left for the fax “handshake.” Make sure you carefully follow instructions in this manual for recording your outgoing message. We do not recommend using the toll-saver feature on your external TAD if it exceeds 4 rings.



Do not connect a TAD elsewhere on the same phone line—your fax machine and TAD will both try to control the line.

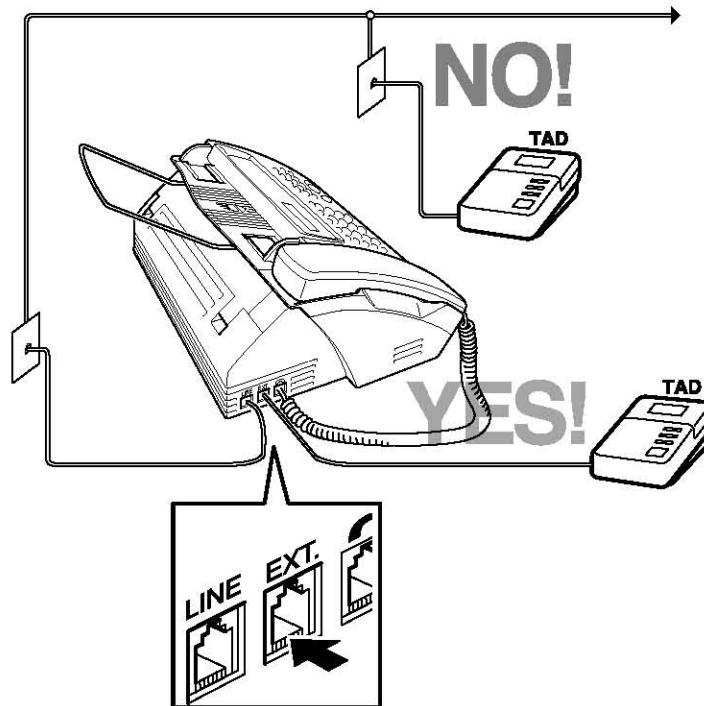

You may connect an external TAD to a separate wall jack only if you subscribe to your telephone company's Distinctive Ring service, have registered the distinctive ring pattern on your fax machine and use that number as a fax number and set your fax machine's Answer mode to MANUAL.

Connections

The external TAD must be plugged into the left side of the fax machine, into the jack labeled EXT. Your fax machine cannot work properly if you plug the TAD into a wall jack.

- 1** Plug the telephone line cord from the wall jack into the left side of the fax machine, in the jack labeled LINE.
- 2** Plug the telephone line cord from your TAD into the left side of the fax machine, in the jack labeled EXT. (Make sure this cord is connected to the TAD at the TAD's telephone line jack, and not its telephone set jack.)
- 3** Set your external TAD to four rings or less. (The fax machine's Ring Delay setting does not apply).
- 4** Record the outgoing message (see next page).
- 5** Set the TAD to answer calls.
- 6** Set the Answer Mode to TAD:ANSWER MACH.

Outgoing Message (OGM)

Timing is important in recording this message. The message sets up the ways to handle both manual and automatic fax reception.

- 1 Record 5 seconds of silence at the beginning of your message. (This allows your fax machine time to listen for the fax CNG tones of automatic transmissions before they stop.)
- 2 Limit your speaking to 20 seconds.
- 3 End your 20-second message by giving your Fax Receive Code for people sending manual faxes. For example:
“After the beep, leave a message or send a fax by pressing * 5 1 and Start.”



We recommend beginning your OGM with an initial 5-second silence because the fax machine cannot hear fax tones over a resonant or loud voice. You may try omitting this pause, but if your fax machine has trouble receiving, then you must rerecord the OGM to include it.

Connecting an External Telephone

Your fax machine is equipped with a handset that you can use as a regular phone. However, you can also connect a separate telephone (or telephone answering device) directly to your fax machine.

Connect the modular plug on the telephone's line cord to the jack labeled EXT. on the left side of the fax machine.

Whenever this phone (or TAD) is in use, the screen displays EXT. TEL IN USE, and, if the fax machine handset is lifted, an alarm sounds. To disconnect the call on the external phone and switch to the fax machine, press **Hook**.

3 On-Screen Programming

User-Friendly Programming

*See
Using This
Manual p. 1*

We have designed your fax machine with on-screen programming and a Help key. User-friendly programming helps you take full advantage of all the functions your fax machine has to offer.

Since your fax programming is done on the LCD, we created step-by-step on-screen prompts to help you program your fax machine. All you need to do is follow the prompts as they guide you through the function menu selections and programming options and settings.

Function Mode

You can access the function mode by pressing **[Function]**. When you enter the function mode, your fax machine displays a list of main menu options from which you can choose. These options appear one after the other on the display. Select a menu option by pressing **[Set]** when the option appears on the screen. The display will scroll the options within that menu.

You can “scroll” more quickly through options by pressing **[▶]**. When the screen displays your selection, press **[Set]**. (Use **[◀]** to scroll backward if you passed your choice or to save key strokes. Both arrow keys show all options, in the opposite order.)

Before you press **[Set]** after entering information in a field using the dial pad, you can correct a mistake. Use **[◀]** to back up and then type over the incorrect characters.

When you finish a function, the screen displays ACCEPTED.

If you want to exit the Function Mode, press **[Stop]**.



Alternating Displays

When you see alternating displays, the LCD sometimes alternates between the currently selected option, and a help message giving brief instructions about how to proceed. The display you'll probably see most often is shown below, showing you, when you place a document in the feeder, that you can dial a number and send a fax, or you can make a copy.



Function Selection Table

If you have a basic understanding of how to program your fax machine, you can perform most of the programming settings without the Owner's Manual. To help you understand the function selections, options, and settings that are found in your fax programs, use the Function Selection Table below.

1. INITIAL SETUP			
Function	Description	Factory Set	Page
1. TONE/PULSE	Selects dialing mode.	TONE	23
2. DATE/TIME	Enter date and time for LCD display and to print on transmissions.	2000 1/1 00:00	23
3. STATION ID	Program name, fax number to appear on each transmitted page.	—	24
4. BEEPER	Adjust volume level of beeper.	LOW	27
5. VOLUME AMPLIFY	For the hearing-impaired, you can set the volume to AMPLIFY:ON, on either a permanent or temporary basis.	OFF	27
2. SETUP RECEIVE			
Function	Description	Factory Set	Page
1. RING DELAY	Number of rings before fax machine answers in FAX/TEL or FAX modes.	RING DELAY: 04	30
2. F/T RING TIME	Sets the time for "double ring" in FAX/TEL mode.	20	31
3. EASY RECEIVE	Receive fax messages without pressing the Start key.	ON	31
4. REMOTE CODE	Enter code to activate or deactivate machine from a remote location.	ON (*51, #51)	33
5. POLLING RX	Sets up your fax machine to poll another fax machine.	OFF	34

3. SETUP SEND			
Function	Description	Factory Set	Page
1. CONTRAST	Change lightness or darkness of a fax you are sending.	AUTO	36
2. RESOLUTION	Allows you to change resolutions page by page.	STANDARD	36
3. OVERSEAS MODE	Adjusts for sometimes difficult overseas transmissions	OFF	38
4. DELAYED FAX	Send documents later.	—	38
5. POLLED TX	Sets up your fax machine with a document to be retrieved by another fax machine.	OFF	40

4. CANCEL JOB			
Function	Description	Factory Set	Page
	Cancel a delayed fax or polling job.		41

5. INTERRUPT			
Function	Description	Factory Set	Page
	Send a fax now, even if you have the machine set to send a fax later, or if you have it set for Polling.		41

6. SET AUTO DIAL			
Function	Description	Factory Set	Page
1. ONE-TOUCH DIAL	Dial numbers stored in memory by pressing only one key.	—	43
2. SPEED-DIAL	Dial numbers stored in memory by pressing only three keys.	—	45

7. PRINT REPORTS

Function	Description	Factory Set	Page
1. XMIT REPORT	Print lists and reports of activity. (Details in Chapter 11)	OFF	60
2. ALL DIAL		—	60
3. TEL. INDEX		—	60
4. USER SETTINGS		—	60

0. TEL SERVICE

Function	Description	Factory Set	Page
1. DISTINCTIVE	Use with phone company distinctive ringing service to register the ring pattern with fax machine.	OFF	51
2. CALLER ID (For USA only)	Register your AREA CODE to dial from log.	000	26

4 Initial Setup

Getting Started

Setting Dialing Mode (Tone/Pulse)

Your fax machine comes set to accommodate tone (multi-frequency) dialing service. If you have pulse (rotary) dialing service, you need to change the dialing mode.

- 1 Press **[Function]**, **[1]**, **[1]**.

DIALING: TONE?

DIALING: PULSE?

- 2 Use **[Left Arrow]** or **[Right Arrow]** to select TONE or PULSE and press **[Set]**.
- 3 Press **[Stop]** to exit.

Setting Date and Time

Your fax machine displays the date and time, and prints it on every fax you send.

In the event of a power failure, the fax machine maintains date and time information for up to two hours. All other settings remain unaffected.

- 1 Press **[Function]**, **[1]**, **[2]**.

ENTER YEAR: XX

- 2 Enter the last two digits of the year and press **[Set]**.

ENTER MONTH: XX

- 3 Enter two digits for the month (for example, enter 09 for September, or 10 for October) and press **[Set]**.

ENTER DAY:XX

- 4 Enter two digits for the day (for example, 06) and press **[Set]**.

ENTER TIME:XX:XX

- 5 Enter the time in 24-hour format (for example, enter 15:25 for 3:25 PM) and press **[Set]**.
- 6 Press **[Stop]**. The screen now displays the date and time you set, and displays it whenever the fax machine is standing by.

Setting Station ID

You can store your name and fax number to be printed on all fax pages.

- 1 Press **[Function]**, **[1]**, **[3]**.

FAX:

- 2 Enter your fax number (up to 20 digits) and press **[Set]**.

NAME:

- 3 Use the dial pad to enter your name or company name (up to 20 characters) and press **[Set]**.
- 4 Press **[Stop]**. The screen returns to the date and time.

*See
Entering Text
p. 25*

Entering Text

When you are setting certain functions, such as the Station ID, you may need to enter text into the fax machine. Most keys on the dial pad have three or four letters printed above them. The keys for 0, # and * don't have printed letters because they are used for special characters.



By pressing the appropriate number on the dial pad the correct number of times, you can access the character you want.

Press Key	one time	two times	three times	four times
2	A	B	C	
3	D	E	F	
4	G	H	I	
5	J	K	L	
6	M	N	O	
7	P	Q	R	S
8	T	U	V	
9	W	X	Y	Z

Inserting Spaces

If you want to enter a blank space, press  twice.

Making Corrections

If you entered a letter incorrectly and want to change it, press  to move the cursor after the last correct letter. Then press ; the letters above and to the right of the cursor are deleted. Re-enter the correct text and/or digits. You can also back up and type over incorrect letters.

Repeating Letters

If you need to enter a character assigned to the same key as the previous character, press  to move the cursor to the right.

Special Characters and Symbols

Press * for (space) ! “ # \$ % & ’ () * + , - . /

Press # for : ; < = > ? @ [] ^ _

Press 0 for É À È Ê Î Ç Ë Ö 0

NOTICE

The Telephone Consumer Protection Act of 1991 makes it unlawful for any person to use a computer or electronic device to send any message via a telephone fax machine unless such messages clearly contain, in a margin at the top or bottom of each transmitted page, or on the first page of the transmission, the date and time it is sent and an identification of the business or other entity or other individual sending the message and the telephone number of the sending machines or such business, other entity or individual.

In order to program this information into your fax machine, complete the steps described on pages 23–24.



- If you do not enter a fax number, no additional information can be entered.
- To enter a space, press  once between numbers and twice between characters.
- If your Station ID has already been programmed, the screen prompts “1” to make a change, or “2” to exit without changing.

Setting Up Your Area Code (For USA Only)

You must set up your area code in Caller ID.

- 1 Press , , .

AREA CODE: 000

- 2 Use the dial pad to enter your area code and press .

AREA CODE: 908

- 3 Press  to exit.

Setting Beeper Volume

You can set the beeper to LOW, HIGH or OFF. The default setting is LOW. When the beeper is set to LOW or HIGH, the fax machine beeps every time you press a key or make an error, and at the end of fax sending or receiving.

- 1 Press **[Function]**, **[1]**, **[4]**.
- 2 Press **[◀]** or **[▶]** to select your setting and press **[Set]**.
- 3 Press **[Stop]** to exit.

Setting the Handset Volume

Before you begin to use the fax machine, you must decide if you need to set the handset volume to AMPLIFY:ON for a user who is hearing-impaired. The AMPLIFY volume level complies with FCC standards.

VOLUME AMPLIFY: OFF

This default setting is appropriate if none of the users are hearing-impaired. During a conversation, users can press **[L▶]** or **[▶H]** on the control panel to adjust the volume. When the handset is replaced, the handset volume remain until you change it again.

VOLUME AMPLIFY: ON-TEMPORARY

This setting is appropriate if *some* of the users are hearing-impaired. During a conversation, users can press **[L▶]** or **[▶H]** on the control panel to adjust the volume to LOW, HIGH or AMPLIFY. When the handset is replaced, the handset volume will returns to the default setting of LOW.

VOL AMPLIFY:ON-PERMANENT

Choose VOL AMPLIFY:ON-PERMANENT if *all* of the users are hearing-impaired. During a conversation, users can press **[L▶]** or **[▶H]** on the control panel to adjust the volume to LOW, HIGH or AMPLIFY. When the handset is replaced, the handset volume returns to the default setting of AMPLIFY.



When you press **[L▶]** or **[▶H]** on the control panel to adjust the volume, the display shows the setting you are choosing. Each key press changes the volume to the next setting.

It is important that you do not choose PERMANENT unless all users are hearing-impaired. Otherwise, the default setting of AMPLIFY may damage the hearing of some users.

Setting Volume Amplify

Please carefully read “Setting the Handset Volume” before you do the following steps:

- 1 Press **[Function]**, **[1]**, **[5]**.

A simulated handset display showing two lines of text. The top line reads "VOL AMPLIFY: OFF?" and the bottom line reads "SELECT <-> & SET". There are curved arrows on either side of the text, indicating that the screen can be scrolled horizontally.

- 2 Press **[Left Arrow]** or **[Right Arrow]** to select VOL AMPLIFY: OFF? if none of the users are hearing-impaired and go to Step 4—OR—If some or all of the users are hearing-impaired, select VOL AMPLIFY: ON?.

A simulated handset display showing two lines of text. The top line reads "PERMANENT?" and the bottom line reads "SELECT <-> & SET". There are curved arrows on either side of the text, indicating that the screen can be scrolled horizontally.

- 3 Press **[Left Arrow]** or **[Right Arrow]** to select PERMANENT? if all the users are hearing-impaired—OR—Select TEMPORARY? if only some of the users are hearing-impaired.
- 4 Press **[Set]**.
- 5 Press **[Stop]** to exit.

Setting the Speaker Volume

You can adjust the speaker volume when your fax machine is onhook (after you pressed **[Hook]**), by selecting a speaker volume level.

Press **[L]** or **[H]** to adjust the volume level. The display shows the setting you are choosing. Each key press changes the volume to the next setting. The new setting will remain until you change it again.

Setting the Ring Volume

You can adjust the ring volume when your fax machine is idle. You can select a ring volume level or press until the ring is off.

Press **[L]** or **[H]** to adjust the volume level. With each key press, the fax machine rings so you can hear the current setting and the display shows the setting you are choosing. Each key press changes the volume to the next setting. The new setting will remain until you change it again.

Memory Storage

In the event of a power failure, all settings in the INITIAL SETUP, SETUP RECEIVE and SET AUTO DIAL functions are stored permanently. You may have to reset the date and time.

Setup Receive

Basic Receiving Operations

Select Answer Mode

*See
Distinctive
Ring
p. 51*

MANUAL—You must answer all calls yourself. If you hear fax tones, press **[Start]** to begin receiving the fax, then hang up. You *must* use this mode with Distinctive Ringing.

FAX ONLY—The fax machine automatically answers every call as a fax call. You cannot receive a voice call, but you can dial out and make a voice call.

*See
For FAX/TEL
Mode Only
p. 33*

FAX/TEL—The fax machine automatically answers every call. If the call is a fax, it prints the fax. If the call is not a fax, it signals you with a double ring (ring-ring), different from the phone company ringing, to alert you to pick up the call. If you select this setting, you'll need to set the Ring Delay and F/T Ring Time features (on the following pages). If you have extension phones on the same line as the fax machine, set the Ring Delay to 4.

TAD—This is the only setting in which you can use an **external** answering machine. Your telephone answering device is connected to your FAX, and answers every call. Once the TAD answers, the FAX listens for fax tones. If it detects fax tones, it prints the fax.

The TAD setting works only with an external telephone answering device (TAD); it does not work with telephone company voice mail. Ring Delay and F/T Ring Time do not work in this setting.

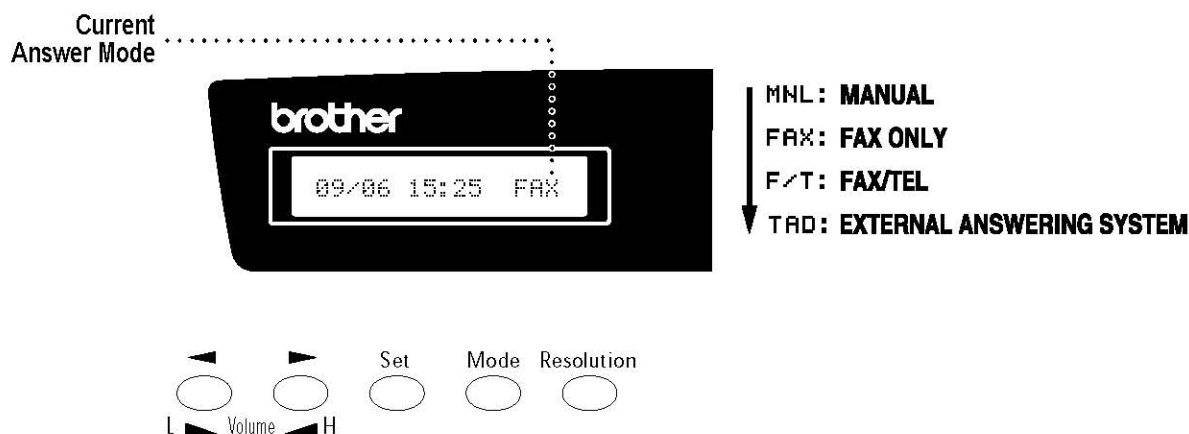

To select or change your Answer Mode

- 1 Press **[Mode]**. The screen displays your current selection.

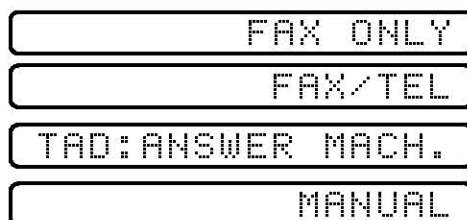

- 2 Continue to press **[Mode]** until your new selection appears. After 2 seconds, the screen returns to the date and time display, along with your new Answer Mode setting.

If you're changing Answer Mode while in another operation, the screen returns to the current operation display.



See
Easy Receive
 p. 31
 and
*Operation from
 Extension
 Telephone*
 p. 32
 and
*For FAX/TEL
 Mode Only*
 p. 33

Setting Ring Delay

The Ring Delay setting determines the number of times the fax machine rings before it answers. If you have extension phones on the same line as the fax machine, keep the Ring Delay default setting of 4.

- 1 Press **[Function]**, **[2]**, **[1]**.
- 2 Press **[◀]** or **[▶]** to select how many times the line rings before the fax machine answers (00 – 04). If you select 00, the line doesn't ring at all and press **[Set]**.
- 3 Press **[Stop]** to exit.

Setting F/T Ring Time

You need to determine how long the fax machine will notify you with its special double-ring when you have a voice call. This double-ringing (F/T Ring Time) happens *after* the initial ringing from the telephone company (Ring Delay). Only the fax machine rings, for 20, 30, 40 or 70 seconds; no other phones on that number will ring the special double-ring. However, you can answer the call on any extension phone on the same phone number as the fax machine.

- 1 Press **[Function]**, **[2]**, **[2]**.
- 2 Press **[◀]** or **[▶]** to select how long the fax machine will ring to alert you that you have a voice call and press **[Set]**.

RING TIME: 20 SEC

- 3 Press **[Stop]** to exit.

Now, when a call comes in and the machine is set to FAX/TEL mode, all phones on this line will ring the number of times you selected in Ring Delay.

You can let the fax machine pick up and detect if it's a fax or voice call. If it's a fax call, the machine prints the fax. If it's a voice call, the machine signals you with a double ring for the length of time you selected in F/T Ring Time.



*See
Operation from
Extension
Telephone
p. 32
and
For FAX/TEL
Mode Only
p. 33*

Even if the caller hangs up during the double ringing, the fax machine continues for the set time.

Easy Receive

When you use this feature, you don't have to press **[Start]** when you answer a fax call and hear calling beeps. Just hold the handset and wait a few seconds. When you see RECEIVE on the fax screen or when you hear "chirps" through the handset of an extension phone connected to another wall jack, just replace the handset, and your machine does the rest. Selecting ON allows the fax machine to receive fax calls automatically, even if you lift the handset of an extension or external phone. Selecting SEMI lets the machine receive the call only if you've answered it at the fax machine. Selecting OFF means you'll have to activate the fax machine yourself, by pressing **[Start]** or by pressing **[*]** **[5]** **[1]** if you are not at your machine.

If you've set the feature to ON, but your fax machine doesn't automatically connect a fax call when you lift an external or extension phone handset, press the Fax Receive code *** 5 1**. At the fax machine, lift the handset and press **Start**.

- 1 Press **Function**, **2**, **3**.
- 2 Use **◀** or **▶** to select ON, SEMI or OFF and press **Set**.
- 3 Press **Stop** to exit.

Advanced Receiving Operations

Operation from Extension Telephone

*See Easy
Receive
p. 31*

*See
Setting F/T
Ring Time
p. 31*

If you answer a fax call on an extension phone or on an external phone in the EXT. jack, you can make your fax machine take over by using the Fax Receive Code. When you press the Fax Receive Code *** 5 1**, the fax machine starts to receive a fax.

If the fax machine answers a voice call and double-rings for you to take over, use the Telephone Answer Code **# 5 1** to take the call at an extension phone.

If you answer a call, and no one is on the line, assume you're receiving a fax. At the fax machine phone, press **Start**, then hang up. At an extension phone, press *** 5 1**, wait for fax receiving tones (chirps), then hang up. At an external phone, press *** 5 1** and wait for the phone to be disconnected (the screen displays RECEIVE) before you hang up. (Your caller will have to press **Start** to send the fax.)

For FAX/TEL Mode Only

When the fax machine is in FAX/TEL mode, it will use the F/T Ring Time (double ringing) to alert you to a voice call. If you're at the fax machine, you can lift the handset to answer.

If you're at an extension phone, you'll need to lift the handset during the F/T Ring Time and press **# 5 1** between the double rings. If no one is on the line, or if someone wants to send you a fax, send the call back to the fax machine by pressing *** 5 1**.

Changing Remote Codes

Remote Codes might not work with some telephone systems. The preset Fax Receive Code is *** 5 1**. The preset Telephone Answer Code is **# 5 1**.



If you are always disconnected when accessing your external TAD remotely, try changing the Fax Receive Code from *** 5 1** to **# # #** and the Telephone Answer Code from **# 5 1** to **9 9 9**.

To change Remote Codes

- 1 Press **Function**, **2**, **4**.
- 2 Press **◀** or **▶** to select ON (or OFF) and press **Set**.

REMOTE ACT. : ON?
- 3 If you want to, enter a new Fax Receive Code, then press **Set**.

FAX RECEIVE : *51
- 4 If you want to, enter a new Telephone Answer Code, then press **Set**.

TEL ANSWER : #51
- 5 Press **Stop** to exit.



Polling

Polling is the process of retrieving faxes from another fax machine. You can use your fax machine to “poll” other machines, or you can have someone poll your machine.

All parties involved in polling need to set up their fax machines to accommodate polling. When someone polls your machine to receive a fax, they pay for the call; if you poll someone’s fax machine to receive a fax, you pay for the call.



Some fax machines do not respond to the polling function.

Setting Up Polling Receive

Polling Receive is when you call another fax machine to receive a fax from it.

- 1 Press **[Function]**, **[2]**, **[5]**.

```
POLLING RX:OFF?
SELECT ← → & SET
```

- 2 Press **[◀]** or **[▶]** to choose ON and press **[Set]**.

```
ENTER FAX NO.
PRESS START KEY
```

- 3 Enter the fax number you are polling.
- 4 Press **[Start]**. The screen displays DIALING.

Setup Send

Before You Begin

- Documents must be between 5.8 and 8.5 inches (148 and 216 mm) wide, and 5.9 and 23.7 inches (150 and 600 mm) long. Your fax machine can only scan an image 8.2 inches (208 mm) wide, regardless of how wide the paper is.
- Make sure you insert documents **face down, top edge first**.
- Adjust the paper guides to fit the width of your document.

Paper guides

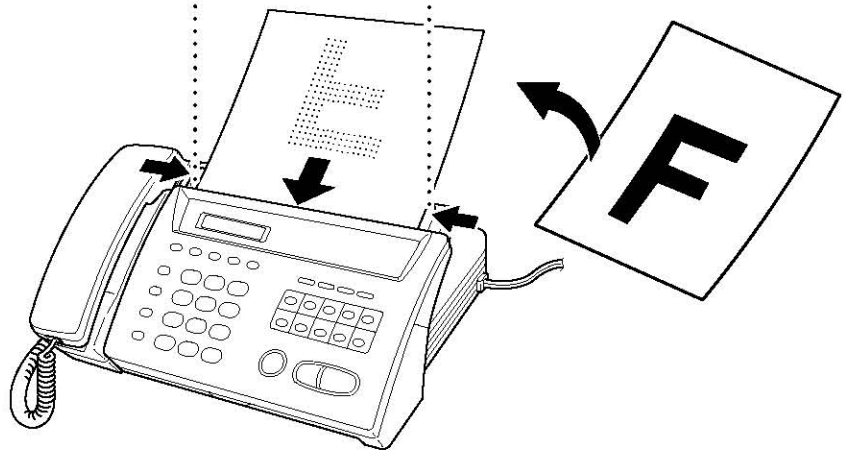

- **DO NOT** use curled, wrinkled, folded or ripped paper, or paper with staples, paper clips, paste or tape attached. **DO NOT** use cardboard, newspaper or fabric.
- Make sure documents written with ink are completely dry.

ADF (Automatic Document Feeder)

The automatic document feeder (ADF) can hold up to 10 pages, feeding each one individually through the fax machine. Use standard (17 lb–24 lb) paper when using the ADF; if you're using heavier paper, feed each sheet individually to prevent paper jams.

Resolution

See
Multiple
Resolution
Transmission
p. 40

Press **[Resolution]** (before you send the fax) to select the resolution for the document you're sending.

Standard—suitable for most typed documents.

Fine—good for small print; transmits a little slower than standard resolution.

S. Fine (Super Fine)—good for small print or artwork; transmits slower than fine resolution.

Photo—use when document has varying shades of gray; slowest transmission time.

If the receiving fax machine does not have the resolution you select, the transmission will fall back to the next available resolution on receiving machine.

Contrast

If your document is very light or very dark, you might want to set the contrast accordingly. Use S.LIGHT to send a very light document. Use S.DARK to send a very dark document.

- 1 Insert the document, face down, in the feeder.
- 2 Press **[Function]**, **[3]**, **[1]**.
- 3 Use **[◀]** or **[▶]** to select AUTO, S.LIGHT or S.DARK and press **[Set]**.

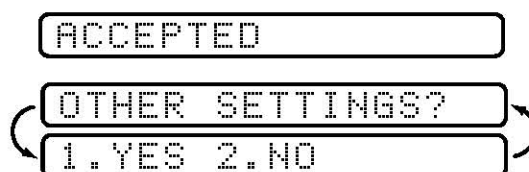

- 4 Press **[2]** if you are finished choosing settings, and go to Step 5—OR— Press **[1]** if you want to select additional settings. The display returns to the Setup Send menu.
- 5 Enter a fax number and press **[Start]** to send a fax.

To set the contrast for a copy, press **[Copy]** in Step 5.



Manual Transmission

Manual transmission lets you hear the dial tone, ringing and fax receiving tones before sending the fax.

- 1** Insert the document face down in the feeder.
- 2** Pick up the handset and listen for a dial tone
—OR—Press **[Hook]** and listen for a dial tone.
- 3** Enter the fax number you want to call (you can enter the digits using the dial pad, or you can enter a One Touch or Speed Dial number or you can call from the Tel-index).
- 4** When you hear the fax tone, press **[Start]**.
- 5** If you're using the handset, hang up.

*See
One-Touch
Dialing
p. 48*

Automatic Transmission

This is the easiest way to send a fax. **IMPORTANT:** Do not pick up the handset, or press **[Hook]**.

- 1** Insert the document face down in the feeder.
- 2** Enter the fax number from One Touch, Speed Dial, Tel-index or the dial pad.
- 3** Press **[Start]**.

*See
Speed Dialing
p. 48*

Manual and Automatic Fax Redial

*If you're sending a fax manually and the line is busy, press **[Redial/Pause]** to retry the number.*

If you're sending a fax automatically and the line is busy, the fax machine will redial automatically up to three times at 5 minute intervals.

Advanced Sending Operations

Overseas Mode

If you have difficulty sending a fax overseas, use the Overseas mode.

After you send a fax using this feature, the feature turns itself off.

- 1 Insert document.
- 2 Press **[Function]**, **[3]**, **[3]**.
- 3 Press **[◀]** or **[▶]** to select ON (or OFF) and press **[Set]**.

3. OVERSEAS MODE

ACCEPTED

OTHER SETTINGS?

1. YES 2. NO

- 4 Press **[1]** if you want to select additional settings. The display returns to the Setup Send menu—OR—Press **[2]** if you are finished choosing settings and go to Step 5.
- 5 Enter the fax number you're calling.
- 6 Press **[Start]**.

Delayed FAX

You can use this function to send a fax up to 24 hours later.

- 1 Insert the document in the feeder.
- 2 Leave the document in the feeder to be scanned at the specified time.
- 3 Press **[Function]**, **[3]**, **[4]**.
- 4 Enter the time you want the fax to be sent, in 24-hour format (for example, enter 19:45 for 7:45 PM) and press **[Set]**.

ACCEPTED

OTHER SETTINGS?

1. YES 2. NO

- 5 Press **[1]** if you want to select additional settings. The display returns to the Setup Send menu—OR—Press **[2]** if you are finished choosing settings and go to Step 6.



- 6 Enter the fax number.
- 7 Press **[Start]**. The fax machine will wait until the time you have entered to send the fax.

Next-Fax Reservation (For FAX 275 Only)

Even if your fax machine is receiving another fax, you can set your machine to send your fax next. This way, you don't have to wait for it to finish sending or receiving the other fax. You can dial this fax call manually, or by using Redial, One Touch, Speed Dial, or Chain dialing. (When you use One Touch and Speed Dial, only the memory location—not the name of the person you're calling—is displayed.)

- 1 Insert the documents in the feeder. If necessary, press **[Resolution]** to adjust resolution.
- 2 Enter the fax number.
- 3 Press **[Start]**.
- 4 Press **[Set]**.

NEXT-FAX RESERVD

To cancel the reservation, remove the documents and press **[Stop]**.

You can't use this feature if there is a document waiting in the feeder (possibly for Delayed Fax or Polling Transmit).



See
Resolution
p. 36

Multiple Resolution Transmission

Use this feature to select separate resolution settings for each page of the fax you're sending. This could be useful if you're sending a fax with photos and letters, or some pages with small print and others with normal print. Resolution settings return to STANDARD after the fax is sent.

- 1 Insert documents in the feeder, then press **[Function]**, **[3]**, **[2]**.
- 2 Use **[◀]** or **[▶]** to select resolution for page 1, then press **[Set]**.
- 3 Repeat Step 2 for subsequent pages.
- 4 Press **[Stop]** when you're finished.

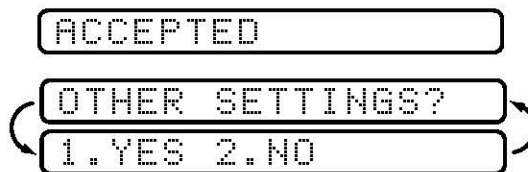

- 5 Press **[1]** if you want to select additional settings. The display returns to the Setup Send menu—OR—Press **[2]** if you are finished choosing settings, and go to Step 6.
- 6 Enter the fax number you're calling.
- 7 Press **[Start]**.

To copy a document using multiple resolutions, press **[Copy]** in Step 6.



Setting Up Polling Transmit

Polling Transmit is when you set up your fax machine to wait with a document so another fax machine can retrieve it.

- 1 Place document to be retrieved in the feeder.
- 2 Press **[Function]**, **[3]**, **[5]**.

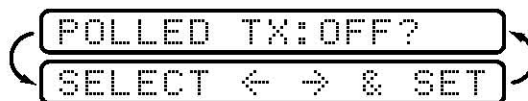

- 3 Press **[◀]** or **[▶]** to choose ON and press **[Set]**.

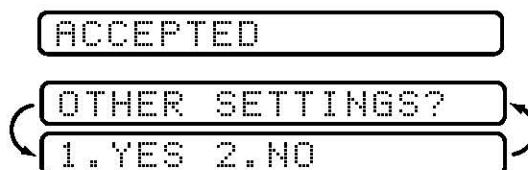

- 4 Press **[1]** if you want to select additional settings. The display returns to the Setup Send menu—OR—Press **[2]** if you are finished choosing settings and go to Step 5.
- 5 Press **[Start]**. The screen displays POLLED WAITING.

Canceling a Scheduled Job

You can cancel tasks you've scheduled, such as Delayed Fax or Polling Transmit.

- 1 Press **[Function]**, **[4]**. Any waiting jobs appear on the display. If there is no job waiting, the screen displays NO JOB WAITING.

4. CANCEL JOB

- 2 If you have more than two jobs waiting, use **[◀]** or **[▶]** to select the job you want to cancel and press **[Set]**.

—OR—

If you have only one job waiting, go to Step 3.

- 3 Press **[1]** to cancel—OR—Press **[2]** to exit without canceling.
- 4 Press **[Stop]** to exit.

Interrupting Delayed Fax and Polling Transmit Jobs

You can send a fax or make a copy now, even if you have the fax machine set to send a fax later, or if you have it set to be polled. However, you cannot use automatic redial or the function mode.

- 1 Press **[Function]**, **[5]**.
- 2 Wait 2 seconds, then remove the documents that are waiting in the feeder.

INSERT DOCUMENT

- 3 Place the document you want to send now in the feeder.
- 4 Enter the number for the fax you want to send now.
- 5 Press **[Start]**.
- 6 After the transmission is finished, return the first document to the feeder.
- 7 Press **[Function]**, **[5]** to restore the Delayed Fax and/or Polling.

Setup Auto Dial Numbers

Storing Numbers for Easy Dialing

You can set up your fax machine to do two types of easy dialing: One Touch and Speed Dial.

Storing One Touch Dial Numbers

*See
One Touch
Dialing
p. 48*

You can store ten fax/phone numbers that you can dial by pressing one key. You also can store names with these numbers. When you press a One Touch dial location, the screen displays the name or number as the call is dialed.

One Touch keys are not the dial pad keys. They are the ten keys (numbers 01–10) located to the right of the dial pad.

- 1 Press **Function**, **6**, **1**.
- 2 Press the One Touch key where you want to store a number. (One Touch key **01** is pre-programmed for Brother Fax-Back System, USA only. You can override it if you wish.)
- 3 Enter a number (up to 20 digits) and press **Set**. If you want to enter a pause in the dialing sequence (for example to wait for an “outside line”), press **Redial/Pause** as you’re entering digits. Pressing **Redial/Pause** enters a 3.5-second pause when the number is dialed, and a dash appears on the screen.

NAME :

- 4** Use the dial pad to enter the name (up to 15 characters) and press **[Set]**. You can use the chart on page 25 to help you enter letters—OR—Go to Step 5 to store the number without a name.

Use **[◀]** or **[▶]** to select the type you want and press **[Set]**.

FAX a fax only number

TEL a telephone (voice) number

FAX/TEL both a fax and telephone (voice) number

CHAIN a number (usually an access code) for chain dialing.

- 5** Return to Step 2 to store another One-Touch number—OR—Press **[Stop]** to exit.

When you dial an AUTO DIAL number, the screen displays the name you've stored, or, if you haven't stored a name, the number you've stored.



If you must wait for another dial tone at any point in the dialing sequence, store a pause at that point in the number by pressing **[Redial/Pause]**. Each key press adds a 3.5 seconds delay.

You can use chain dialing to store long dialing sequences. For example, to store 9 1 201 555 1234 987 65 4321, divide the number into two parts. Store the first part as a Chain type number (this tells the system that the dialing sequence is not complete).

CHAIN—9 1 201 555 1234

The last part of the One-Touch number must be stored as any of the other following three types.

FAX or FAX/TEL or TEL—987 65 4321

Now, when you dial, just press the two keys (one after the other, in order) where you've stored the two parts of the number.

Access Codes and Credit Card Numbers

Sometimes you may want to choose from among several long distance carriers when you make a call. Rates may vary depending upon the time and destination. To take advantage of low rates, you can store the access codes or long-distance carriers as One Touch numbers. You can store these long dialing sequences by dividing them and setting them up on separate keys in any combination. You can even include manual dialing using the dial pad. The combined number will be dialed in the order you entered it, as soon as you press **[Start]**.

*See
Storing One
Touch Dial
Numbers
p. 43*

You can store “555” on One Touch key **[03]** and “7000” on One Touch key **[02]**. If you press One Touch **[03]**, **[02]**, and **[Start]**, you can dial “555-7000”. To temporarily change a number, you can substitute part of the number with manual dialing using the dial pad. For example, to change the number to 555-7001 you could press One Touch **[03]** and press **[7]**, **[0]**, **[0]**, **[1]** using the dialing pad.

Storing Speed Dial Numbers

*See
Speed Dialing
p. 48*

You can store Speed Dial numbers, so when you dial you only have to press three keys. There are 10 (FAX 255), 15 (FAX 275) Speed Dial locations. Even if you lose electrical power, numbers stored in memory will not be lost.

- 1 Press **[Function]**, **[6]**, **[2]**.

SPEED-DIAL? #

- 2 Use the dial pad to enter a two-digit location and press **[Set]** (01–10) FAX 255, (01–15) FAX 275.

#05:

ENTER & SET

- 3 Enter the number you’re storing (up to 20 digits) and press **[Set]**.

NAME:

ENTER & SET

- 4 Use the dial pad to enter the name (up to 15 characters) and press **[Set]**. You can use the chart on page 25 to help you enter letters—OR—Press **[Set]** and go to Step 5 to store the number without a name.

- 5 Use **[Left Arrow]** or **[Right Arrow]** to select the type you want and press **[Set]**.

FAX a fax number

TEL a telephone (voice) number

FAX/TEL both a fax and telephone number

CHAIN a number (usually an access code) for chain dialing

- 6 Return to Step 2 to store another Speed Dial number—OR—Press **[Stop]** to exit.

Changing One Touch and Speed Dial Numbers

If you try to store a One Touch or Speed Dial number in a location where a number is already stored, the screen displays the current name stored there, then prompts you to either

1. CHANGE—OR—2. EXIT.

- 1 Press **[1]** to change the number stored, or press **[2]** to exit without making a change.
- 2 Enter a new number and press **[Set]**.
 - If you want to erase the whole number, press **[Stop]** when the cursor is to the left of the digits. The letters above and to the right of the cursor are deleted.
 - If you want to change a digit, use **[◀]** or **[▶]** to position the cursor under the digit you want to change, then type over it.
- 3 Follow the directions from Step 3 in Storing One Touch Numbers or in Storing Speed Dial Numbers.

Telephone Operation

Dialing Options

You can use your fax machine to make voice telephone calls, by dialing manually, or by using Tel-index, One Touch or Speed Dial memory. You can use the handset.

Manual Dialing

Manual dialing is simply pressing all of the digits of the phone number.

- 1 Pick up the handset—OR—Press **[Hook]**.
- 2 When you hear a dial tone, dial the call, using the dial pad.
- 3 If you pressed **[Hook]** when dialing a voice call, pick up the handset when the other party answers. (The speaker works only one way; the other party won't be able to hear you unless you pick up the handset.)
- 4 To hang up a voice call, replace the handset.

See
Storing One
Touch Dial
Numbers
p. 43

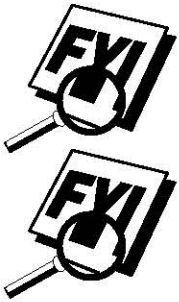

One Touch Dialing

- 1 Pick up the handset—OR—Press **[Hook]**.
- 2 When you hear a dial tone, press the One Touch key of the location you want to call.
- 3 If you pressed **[Hook]** to dial the call, pick up the handset when the other party answers. (The speaker works only one way; the other party won't be able to hear you unless you pick up the handset.)
- 4 To hang up a voice call, replace the handset.

If you try to use a One Touch location with no number stored in it, you hear a warning sound, and screen displays NOT REGISTERED. The display returns to normal after 2 seconds.

If you are sending a fax, press **[Start]** after pressing the One Touch key. If you picked up the handset, press **[Start]** when the receiving fax machine answers with fax tones.

Speed Dialing

See
Storing Speed
Dial Numbers
p. 45



- 1 Pick up the handset—OR—Press **[Hook]**.
- 2 When you hear a dial tone, press **[Speed Dial]**, then press the two-digit Speed Dial number.
- 3 If you pressed **[Hook]** to dial the call, pick up the handset when the other party answers. (The speaker works only one way; the other party won't be able to hear you unless you pick up the handset.)
- 4 To hang up, replace the handset.

If you are sending a fax, press **[Start]** after entering the Speed Dial number. If you picked up the handset, press **[Start]** when the receiving fax machine answers with fax tones.

Hold

- 1 Press **[Hold/Caller ID]** to put a call on Hold.
- 2 You can put down the handset without disconnecting the call.
- 3 Pick up the fax machine handset to release the call from Hold. Picking up an extension handset will not release the call from Hold.

Pause

Press **[Redial/Pause]** to insert a pause between numbers. Each key press adds a 3.5 second delay.

Tone/Pulse

If you have pulse dialing service, but need to send tone signals (for telephone banking, for example), follow the directions below. If you have touch tone service, you do not need this feature to send tone signals.

- 1 Lift the handset.
- 2 Press **[#]**. Any digits dialed after this send tone signals.
- 3 When you hang up, the fax machine returns to pulse dialing service.

Searching Telephone Index

You can search for names you have stored in One Touch and Speed Dial memories. Names are stored alphabetically.

- 1 Press **[Tel-index]**, then enter the first letter of the name you're looking for.
- 2 Press **[◀]** or **[▶]** to search the memory.
- 3 When the screen displays the name you want to call, pick up the handset or press **[Hook]**.
- 4 Press **[Start]** to begin dialing.
- 5 If you pressed **[Hook]** to dial the call, pick up the handset when the other party answers. (The speaker works only one way; the other party won't be able to hear you unless you pickup the handset.)
- 6 When the call is over, hang up to cancel the call.

*See
Storing One
Touch Dial
Numbers
p. 43
and
Storing Speed
Dial Numbers
p. 45*

Telephone Service

Custom Features

Your fax machine supports the Distinctive Ring and Caller ID telephone services offered by some telephone companies.



If you have Call Waiting, Ring Master, Voice Mail, an answering service or an alarm system custom feature on your telephone line, it may create a problem in the operation of your fax machine.

Distinctive Ring

This fax machine feature lets you use the Distinctive Ring subscriber service offered by some telephone companies, which allows you to have several telephone numbers on one phone line. Each phone number has its own Distinctive Ring pattern, so you know which phone number is ringing. This is one way you can have a separate phone number for your fax machine.

Your fax machine has a Distinctive Ring function, allowing you to dedicate one phone number just for receiving faxes. You'll need to follow the directions below to "register" the new Distinctive Ring pattern, that was assigned by the Telephone Company, so your fax machine can recognize its incoming calls.



You can change or cancel the Distinctive Ring pattern at any time. You can switch it off temporarily, then turn it back on. When you get a new fax number, make sure you reset this function.



You can register only one Distinctive Ring pattern with the fax machine. Some ring patterns cannot be registered.

- The fax machine will answer only calls to its registered number.
- To have your TAD answer only the main number, the fax machine must be in Manual Mode.
- In FAX/TEL or FAX ONLY mode, the fax machine will answer all numbers on the phone line.
- The first two rings are silent on the fax machine and on a telephone or TAD connected to its EXT jack.

Registering the Distinctive Ring Pattern

- 1 If you have Voice Mail from the Telephone Company, you must disconnect it now (temporarily).
- 2 Disconnect the fax machine from any TAD or external telephone answering device.
- 3 Set the fax machine to **MANUAL** mode.
- 4 Press **Function**, **0**, **1**. The screen displays the current setting of this feature.
- 5 Press **◀** or **▶** to select the **DISTINCTIVE: SET?** mode and press **Set**.

DISTINCTIVE: OFF?

DISTINCTIVE: SET?

- 6 Press **◀** or **▶** to select the prestored ring pattern you want to assign and press **Set**. (You will hear each pattern as you scroll through the four patterns.) Be sure to choose the pattern assigned by the Telephone Company.

Ring Pattern	Rings	
1	long - long	
2	short - long - short	
3	short - short - long	
4	very long (normal pattern)	

7 Press **[Stop]** to exit.

Once you've registered the Distinctive Ring pattern in your fax machine, you can turn this feature ON (or OFF), by following Steps 1 to 5 above.

Caller ID

The Caller ID feature of this fax machine lets you use the Caller ID subscriber service offered by many local telephone companies. After at least two rings, the screen displays the telephone number of your caller (or up to 16 characters of the name, if available). Once you pick up the handset, the Caller ID information disappears from the screen, but the call information remains stored in the Caller ID memory.

- CALL PICKUP display remains on the screen when no Caller ID information was transmitted.
- OUT-OF-AREA display means the call originates outside your Caller ID service area.
- PRIVATE CALL display means the caller has intentionally blocked transmission of information.

Caller ID service varies with different carriers. Call your local telephone company to determine the kind of service available in your area.

Caller ID Log

Your fax machine stores up to 20 of the last caller IDs received into the fax machine's memory in the Caller ID Log. When the twenty-first call comes in, information about the first call is erased. You can print the report or scroll through Caller ID information to review those calls made to your fax machine.

Printing the Caller ID Log

1 Press **[Hold/Caller ID]**.

CALLER ID LOG

2 To print the Caller ID Log, press **[Start]**.

PRINTING

Viewing the Caller ID Log

- 1 Press **Hold/Caller ID**.

```
CALLER ID LOG
PRESS START KEY
SELECT ← → & SET
```

- 2 After 2 seconds, press **◀** or **▶** to scroll through the Caller ID Log.

```
01>MARY HENDERSON
02>TOM HENDERSON
03>ABC COMPANY
```

- 3 When you want to see more detailed information for a displayed ID (phone number and date and time call was received) press **Set**.

```
03>ABC COMPANY
03>9087772837
03>02/01 12:00
DIAL:PRESS START
```

- 4 To continue viewing the Caller ID Log (Step 2), press **◀** or **▶**.
—OR—
To exit the Caller ID Log, press **Stop**.

*See Up
Setting Your
Area Code
p. 26*

Returning a Call from the Log

You can scroll through the Caller ID Log and select a call to return automatically.

You must set up your AREA CODE in advance. (USA only)

- 1 Press **[Hold/Caller ID]**.

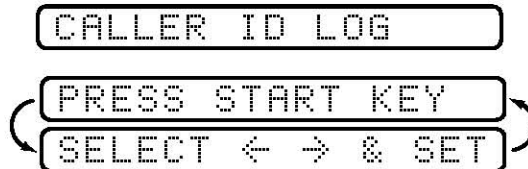

- 2 Press **[Left Arrow]** or **[Right Arrow]** to scroll through the Caller ID Log and when you see a call you want to return immediately, press **[Set]**.

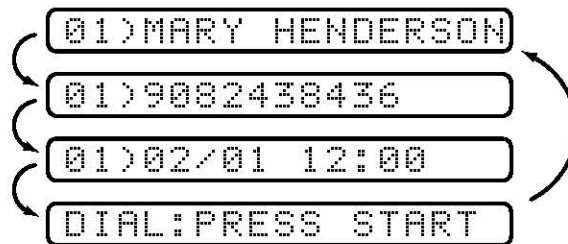

- 3 To begin dialing, press **[Start]**.
- 4 Begin speaking when the other party answers.



This feature may not be available in certain area of USA and Canada.

If your dialing plan does not follow the standard 1 + area code + 7-digit number dialing system for calling outside your area code, you may experience problems returning calls automatically from the Caller ID Log. Your fax machine will automatically dial “1” plus the area code for any number that does not originate in your area code. If this is not the procedure followed by your dialing plan you will not be able to return calls automatically.

Registering a Caller ID Number

You can set up a caller in the Caller ID Log as a One Touch or Speed Dial number.

- 1** Press **[Hold/Caller ID]**.

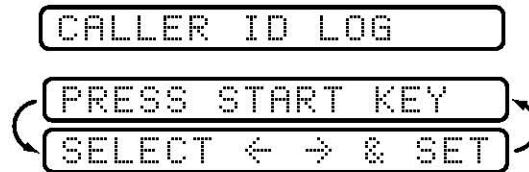

- 2** After 2 seconds, press **[Left Arrow]** or **[Right Arrow]** to scroll through the Log and when you see a caller you want to register, press **[Set]**.

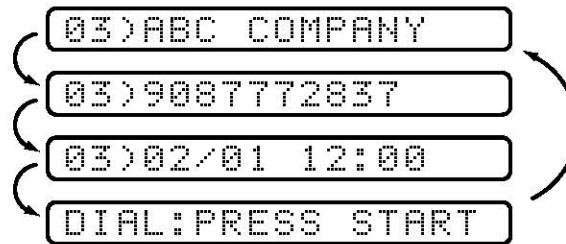

- 3** To register the caller as a One Touch number, press the One Touch key where you want the number to be stored.

—OR—

To register the caller as a Speed Dial number, press **[Speed Dial]** and use the dial pad to press the two-digit location code (01–10) FAX 255, (01–15) FAX 275 and press **[Set]**.



If the LCD shows REGISTERED, the auto dial location already has a number.

- 4** Enter the caller's name and press **[Set]**.

- 5** Press **[Left Arrow]** or **[Right Arrow]** to select the type of number and press **[Set]**:

FAX A fax number

TEL A telephone (voice) number

FAX/TEL Both a fax and telephone number

CHAIN A number, usually an access code, for chain dialing

- 6** Return to Step 2 to store another auto dial number—OR—
Press **[Stop]** to exit.

Making Copies

Copy Functions

Your fax machine cannot scan anything closer than one-eighth inch from the edge of the paper. The default resolution for a single copy is Super Fine. Set the resolution to PHOTO for photographs.

- 1 Place document face down in the feeder.
- 2 Press **Copy**.

To cancel, press **Stop**.

Do NOT pull on the paper while copying is in progress.



Printing Reports

FAX Settings

You can print the following lists and reports:

1. XMIT REPORT

Choose if you would like a Transmission Verification Report printed after all faxes you send.

2. ALL DIAL

Lists names and numbers stored in One Touch and Speed Dial memory, in numerical order.

3. TEL. INDEX

ALL DIAL list (above), alphabetically.

4. USER SETTINGS

Lists settings for INITIAL SETUP, SETUP RECEIVE, PRINT REPORTS and TEL SERVICE.

To Print a Report

- 1 Press **[Function]**, **[7]**.
- 2 Enter the number of the report you want to print. For example, press **[3]** to print the TEL-INDEX.
- 3 Press **[Start]**.
- 4 Press **[Stop]** to exit.

Transmission Verification (Xmit) Report

You can use the Xmit Report as proof that you sent a fax. This report lists the name or fax number of the receiving party, the time and date of transmission, and if the transmission was successful.

When the feature is OFF, the report is printed automatically only if there's an error during transmission. If the report indicates NG, send the document again. If the report indicates you should check the readability of certain pages, resend those pages. For successful transmissions, you can print the Xmit Report for the last fax by pressing **[Trans. Verify]**.

When the feature is ON, the report is printed with every fax you send.

- 1 Press **[Function]**, **[7]**, **[1]**.
- 2 Press **[◀]** or **[▶]** to select ON (or OFF) and press **[Set]**.
- 3 Press **[Stop]** to exit.

Using the Trans. Verify Key

To print the Transmission Verification (Xmit Report) for only a few important faxes, turn the report off (**[Function]**, **[7]**, **[1]**). Then you can press the **[Trans. Verify]** key to print the Xmit Report for the *last* fax you sent.

Important Information

Standard Telephone and FCC Notices

These notices are in effect on models sold and used in the United States only.

This equipment is hearing aid and volume control compatible.

When programming emergency numbers and/or making test calls to emergency numbers:

- Remain on the line and briefly explain to the dispatcher the reason for the call before hanging up.
- Perform such activities in the off-peak hours, such as early morning or late evening.

This equipment complies with Part 68 of FCC Rules. On the rear panel of this equipment is a label that contains, among other information, the FCC Registration Number and Ringer Equivalence Number (REN) for this equipment. You must, upon request, provide this information to your telephone company.

You may safely connect this equipment to the telephone line by means of a standard modular jack, USOC RJ11C.

An FCC compliant telephone cord with a modular plug is provided with this equipment. This equipment is designed to be connected to the telephone line or premise's wiring using a compatible modular jack that is Part 68 compliant. See the Installation section of this manual for details.

The REN is useful to determine the quantity of devices you may connect to your telephone line and still have those devices ring when your telephone number is called. In most, but not all areas, the sum of the RENs of all devices connected to one line should not exceed five (5). To be certain of the number of devices you may connect to your line, as determined by the REN, you should contact your local telephone company to determine the maximum REN for your calling area. If your fax damages the telephone line, the telephone company may discontinue your service temporarily. If possible, they will notify you in advance. But if advance notice is not practical, you will be notified as soon as possible. You will be informed of your right to file a complaint with the FCC.

Your telephone company may make changes to its facilities, equipment, operations or procedures that could affect the proper functioning of your equipment. If they do, you will be notified in advance to give you an opportunity to maintain uninterrupted telephone service.

If you experience trouble with this fax machine, please contact a Brother Authorized Service Center for information on obtaining service or repair. The telephone company may ask that you disconnect this equipment from the line until the problem has been corrected or until you are sure that the equipment is not malfunctioning.

If you are not able to solve a problem with your fax machine, contact Brother at

USA: *1-800-284-4329 (voice)*

1-908-575-8790 (fax)

From within Canada: *1-800-853-6660 (voice)*

1-514-685-4898 (fax)

From within Montreal: *1-514-685-6464 (voice)*

Federal Communications Commission Compliance Notice (For USA Only)

This equipment has been tested and found to comply with the limits for a Class B digital device, pursuant to Part 15 of the FCC Rules. These limits are designed to provide reasonable protection against harmful interference in a residential installation. This equipment generates, uses, and can radiate radio frequency energy and, if not installed and used in accordance with the instructions, may cause harmful interference to radio communications. However, there is no guarantee that interference will not occur in a particular installation. If this equipment does cause harmful interference to radio or television reception, which can be determined by turning the equipment off and on, the user is encouraged to try to correct the interference by one or more of the following measures:

- Reorient or relocate the receiving antenna.
- Increase the separation between the fax equipment and the receiver.
- Connect the fax equipment on a separate circuit.
- Consult with the dealer or an experienced radio/TV technician for help.

Industry Canada Compliance Statement (For Canada Only)

This Class B digital apparatus complies with Canadian ICES-003.

Cet appareil numérique de la classe B est conforme à la norme NMB-003 du Canada.



WARNING

For protection against the risk of electrical shock, always disconnect all cables from the wall outlet before servicing, modifying or installing the equipment.

This equipment may not be used on coin service lines provided by the telephone company or connected to party lines.

Brother cannot accept any financial or other responsibilities that may be the result of your use of this information, including direct, special or consequential damages. There are no warranties extended or granted by this document.

The serial number may be found on the label affixed to the back of the unit. For your convenience, note the number below and retain this Owner's Manual to serve as a permanent record of your purchase, in the event of a theft or fire, or for future reference.

Important Safety Instructions

- 1** Read all of these instructions.
- 2** Save them for later reference.
- 3** Follow all warnings and instructions marked on the product.
- 4** Unplug this product from the wall outlet before cleaning. Do not use liquid or aerosol cleaners. Use a damp cloth for cleaning.
- 5** Do not use this product near water.
- 6** Do not place this product on an unstable cart, stand, or table. The product may fall, causing serious damage to the product.
- 7** Slots and openings in the cabinet and the back or bottom are provided for ventilation; to ensure reliable operation of the product and to protect it from overheating, these openings must not be blocked or covered. The openings should never be blocked by placing the product on a bed, sofa, rug, or other similar surface. This product should never be placed near or over a radiator or heater. This product should never be placed in a built-in installation unless proper ventilation is provided.
- 8** This product should be operated from the type of power source indicated on the label. If you are not sure of the type of power available, consult with your dealer or local power company.
- 9** This product is equipped with a 3-wire grounding type plug, a plug having a third (grounding) pin. This plug will fit into only a grounding-type power outlet. This is a safety feature. If you are unable to insert the plug into the outlet, contact your electrician to replace your obsolete outlet. Do not defeat the purpose of the grounding-type plug.
- 10** Do not allow anything to rest on the power cord. Do not place this product where people can walk on the cord.
- 11** If an extension cord is used with this product, make sure that the total ampere ratings on the products plugged into the extension cord do not exceed the extension cord ampere rating. Also, make sure that the total of all products plugged into the wall outlet does not exceed 15 amperes (USA only).
- 12** Do not place anything in front of the fax machine that will block received faxes. Do not place anything in the path of received faxes.
- 13** Do not touch a document during printing.
- 14** Never push objects of any kind into this product through cabinet slots, since they may touch dangerous voltage points or short out parts resulting in a risk of fire or electric shock. Never spill liquid of any kind on the product.

15 Do not attempt to service this product yourself, as opening or removing covers may expose you to dangerous voltage points and/or other risks, and may void your warranty. Refer all servicing to a Brother Authorized Service Center. A list of Brother Authorized Service Centers has been included for your convenience, or you may contact the following Brother Customer Service Numbers for your nearest Brother Authorized Service Center:

USA: *1-800-284-4329 (voice)*
1-908-575-8790 (fax)
1-800-521-2846 (Fax-Back System)

From within Canada: *1-800-853-6660 (voice)*
1-514-685-4898 (fax)
1-800-681-9838 (Fax-Back System)

From within Montreal: *1-514-685-6464 (voice)*

16 Unplug this product from the wall outlet and refer servicing to a Brother Authorized Service Center under the following conditions:

- A** When the power cord is damaged or frayed.
- B** If liquid has been spilled into the product.
- C** If the product has been exposed to rain or water.
- D** If the product does not operate normally when the operating instructions are followed. Adjust only those controls that are covered by the operating instructions. Improper adjustment of other controls may result in damage and will often require extensive work by a qualified technician to restore the product to normal operation.
- E** If the product has been dropped or the cabinet has been damaged.
- F** If the product exhibits a distinct change in performance, indicating a need for service.

17 To protect your product against power surges, we recommend the use of a power protection device (Surge Protector).

Compilation and Publication Notice

Under the supervision of Brother Industries, Ltd., this manual has been compiled and published, covering the latest product descriptions and specifications.

The contents of this manual and the specifications of this product are subject to change without notice.

Brother reserves the right to make changes without notice in the specifications and materials contained herein and shall not be responsible for any damages (including consequential) caused by reliance on the materials presented, including but not limited to typographical and other errors relating to the publication.

Trademarks

The Brother logo is a registered trademark of Brother Industries, Ltd.

Brother is a registered trademark of Brother Industries, Ltd.

All other terms and brand and product names mentioned in this manual are registered trademarks of their respective companies.

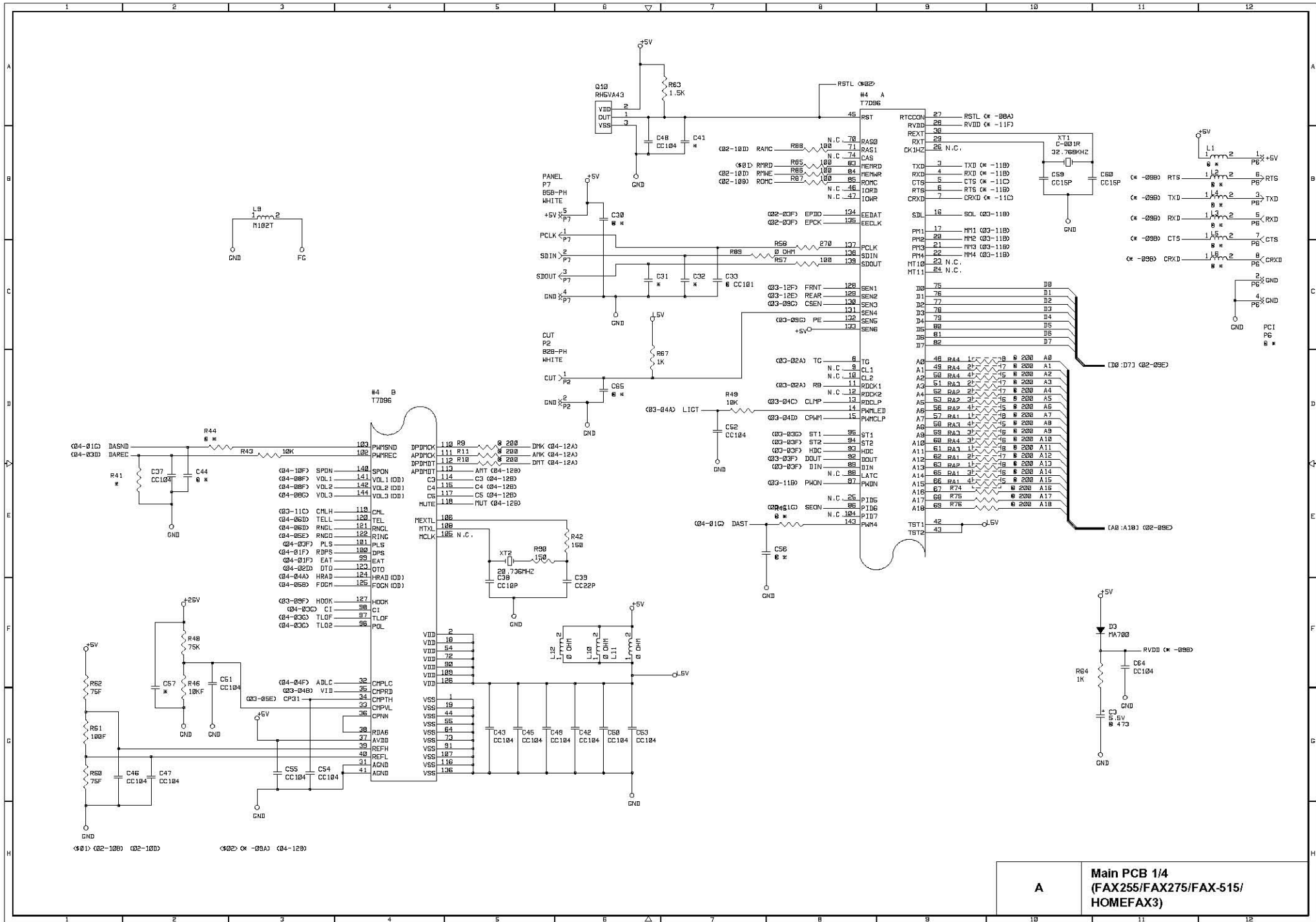

A Main PCB 1/4 (FAX255/FAX275/FAX-515/HOMEFAX3)

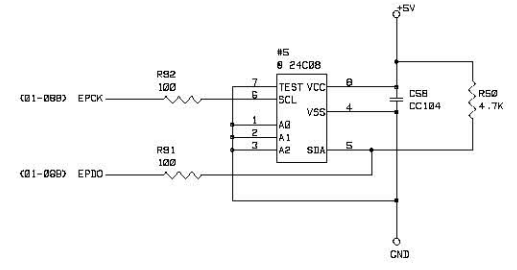
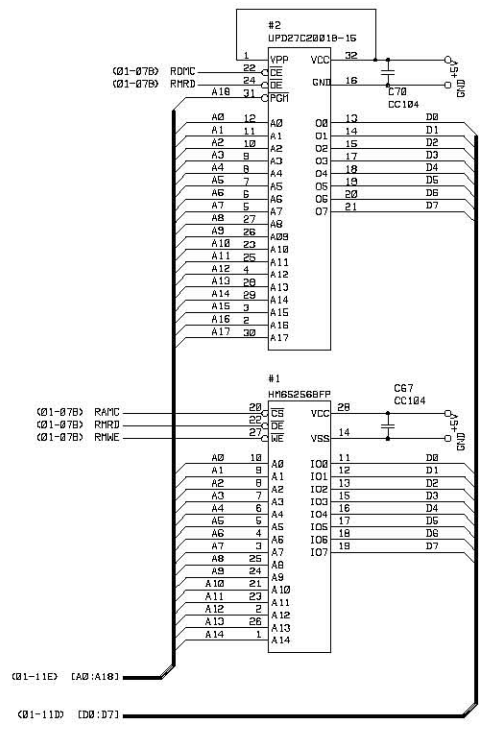
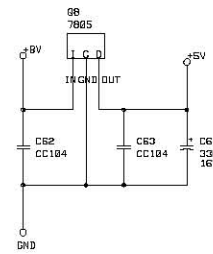
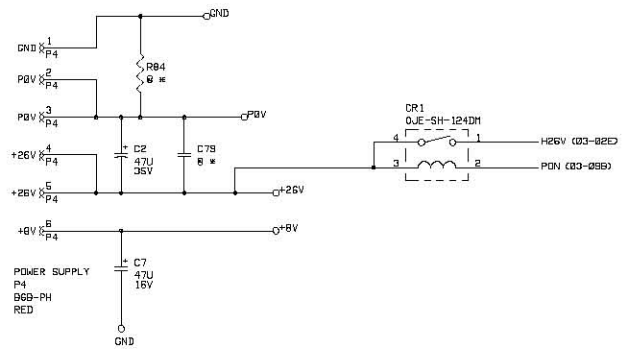

1 2 3 4 5 6 7 8 9 10 11 12

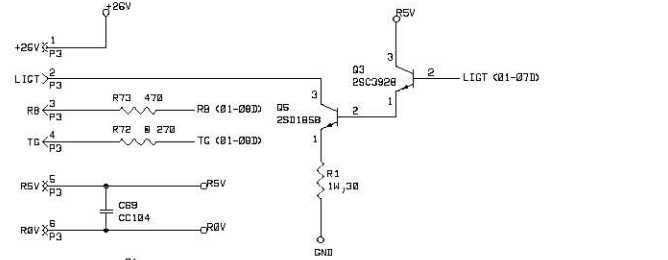

NOTE:R0V SHORTED TO GND AT ONE POINT
NOTE:R5V SHORTED TO +5V AT ONE POINT

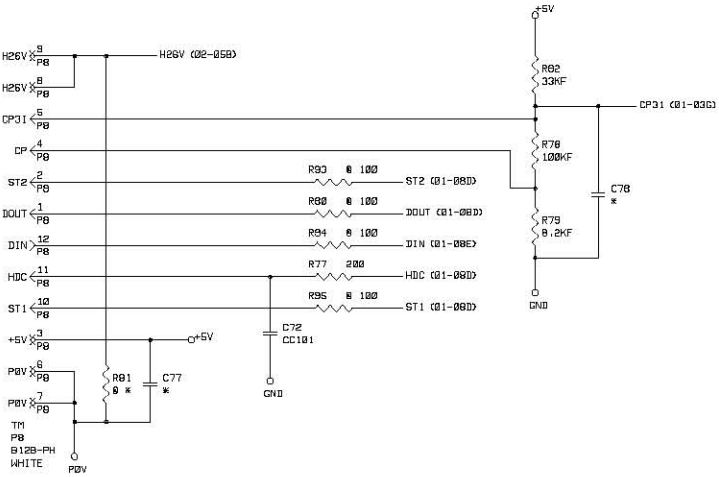
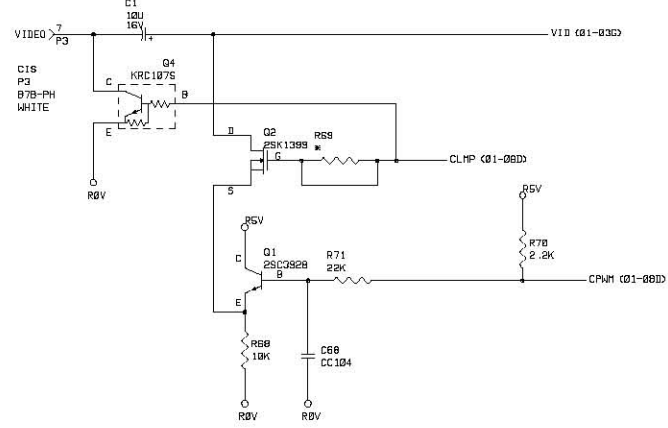

(Q1) (Q1-03E) (Q4-06D)

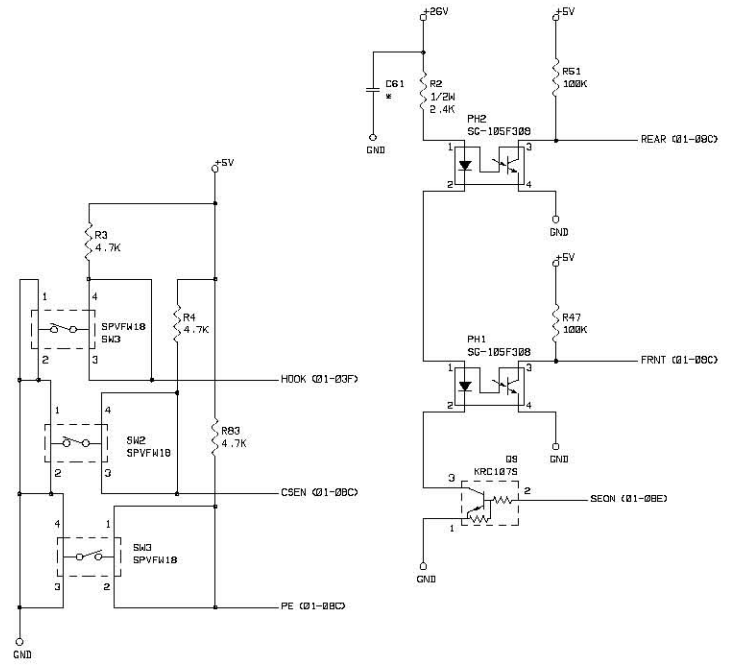
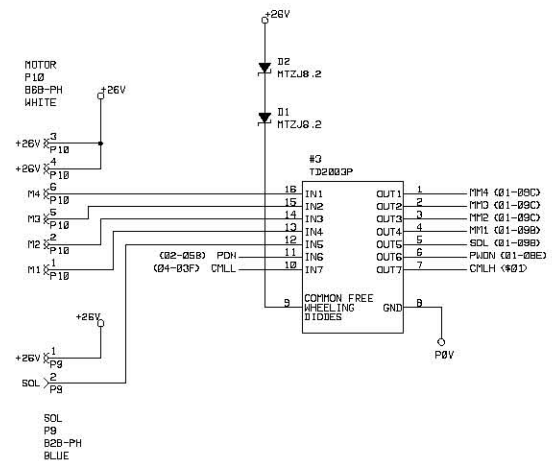

A Main PCB 3/4
(FAX255/FAX275/FAX-515/
HOMEFAX3)

1 2 3 4 5 6 7 8 9 10 11 12

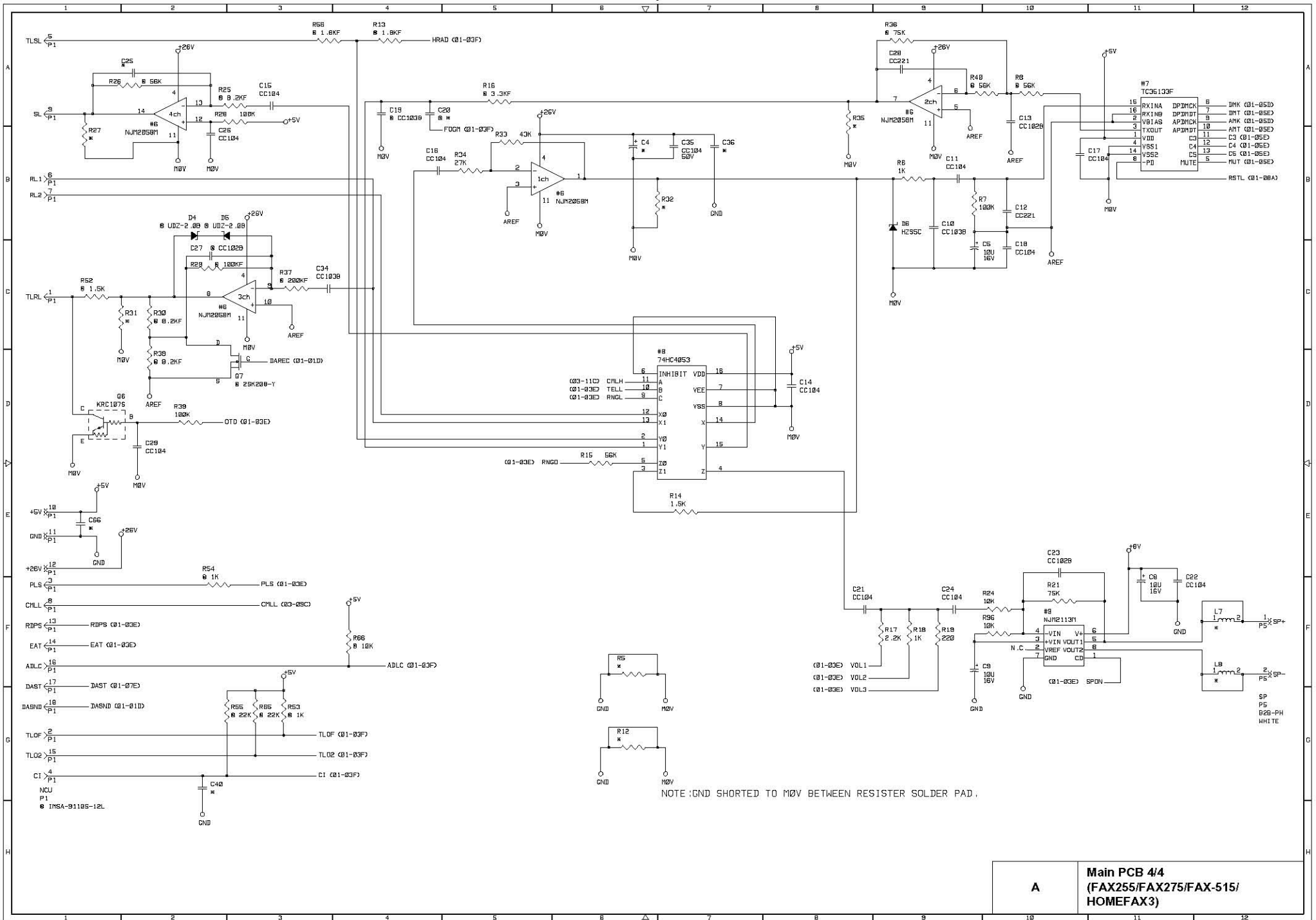

A Main PCB 4/4
(FAX255/FAX275/FAX-515/
HOMEFAX3)

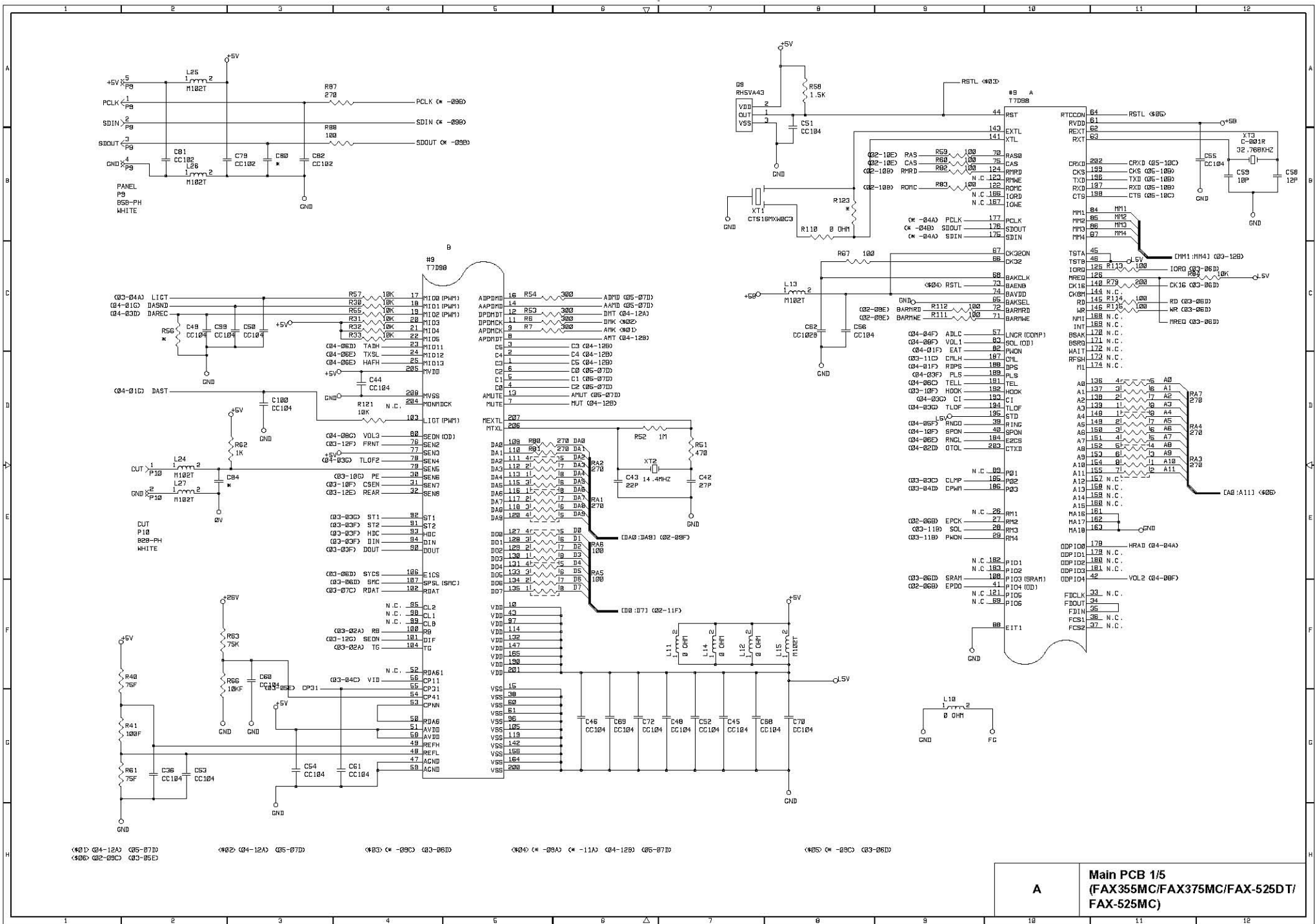

A Main PCB 1/5
(FAX355MC/FAX375MC/FAX-525D/
FAX-525MC)

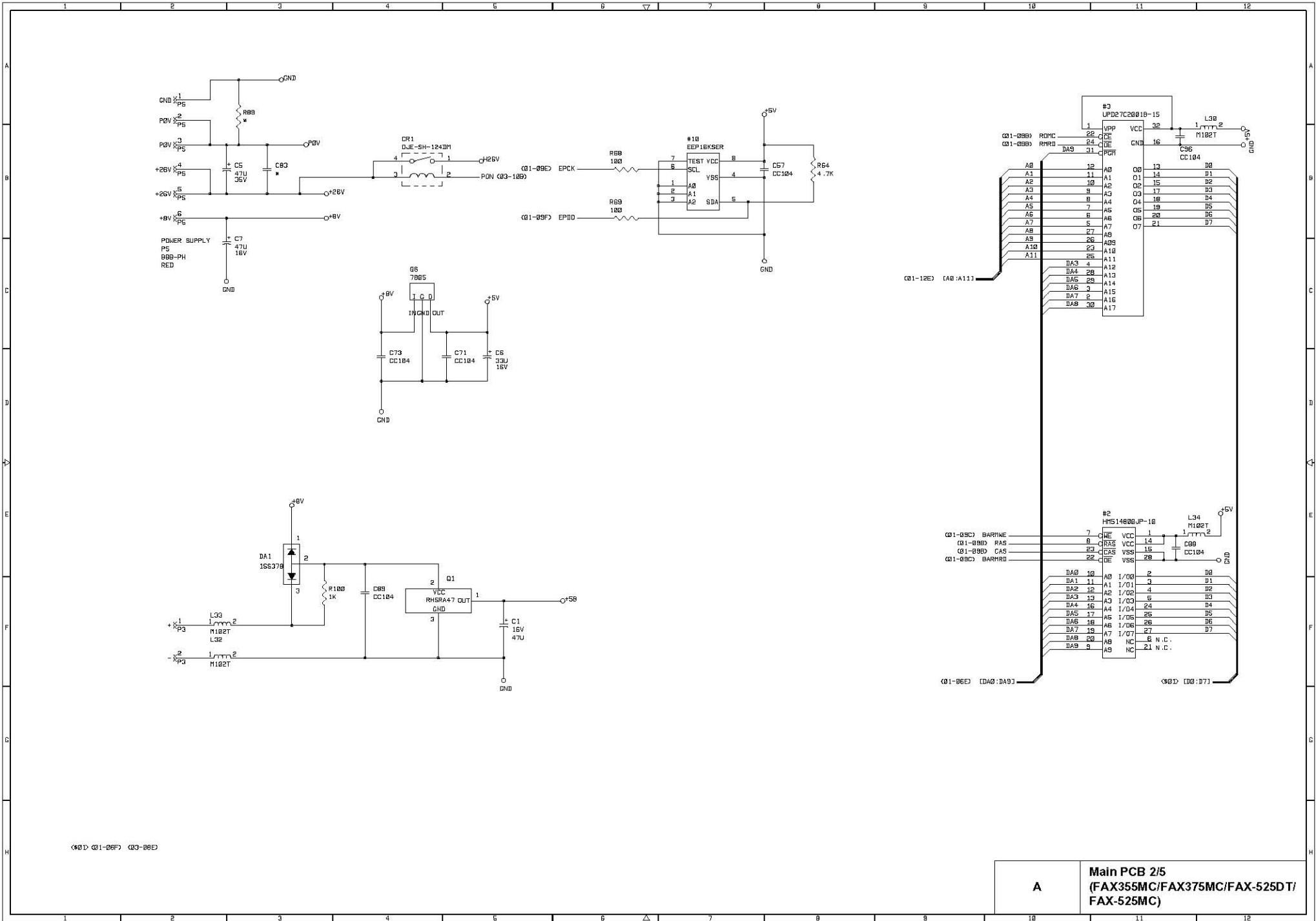

(K0) (Q1-08F) (Q3-08E)

A

Main PCB 2/5
(FAX355MC/FAX375MC/FAX-525DT/
FAX-525MC)

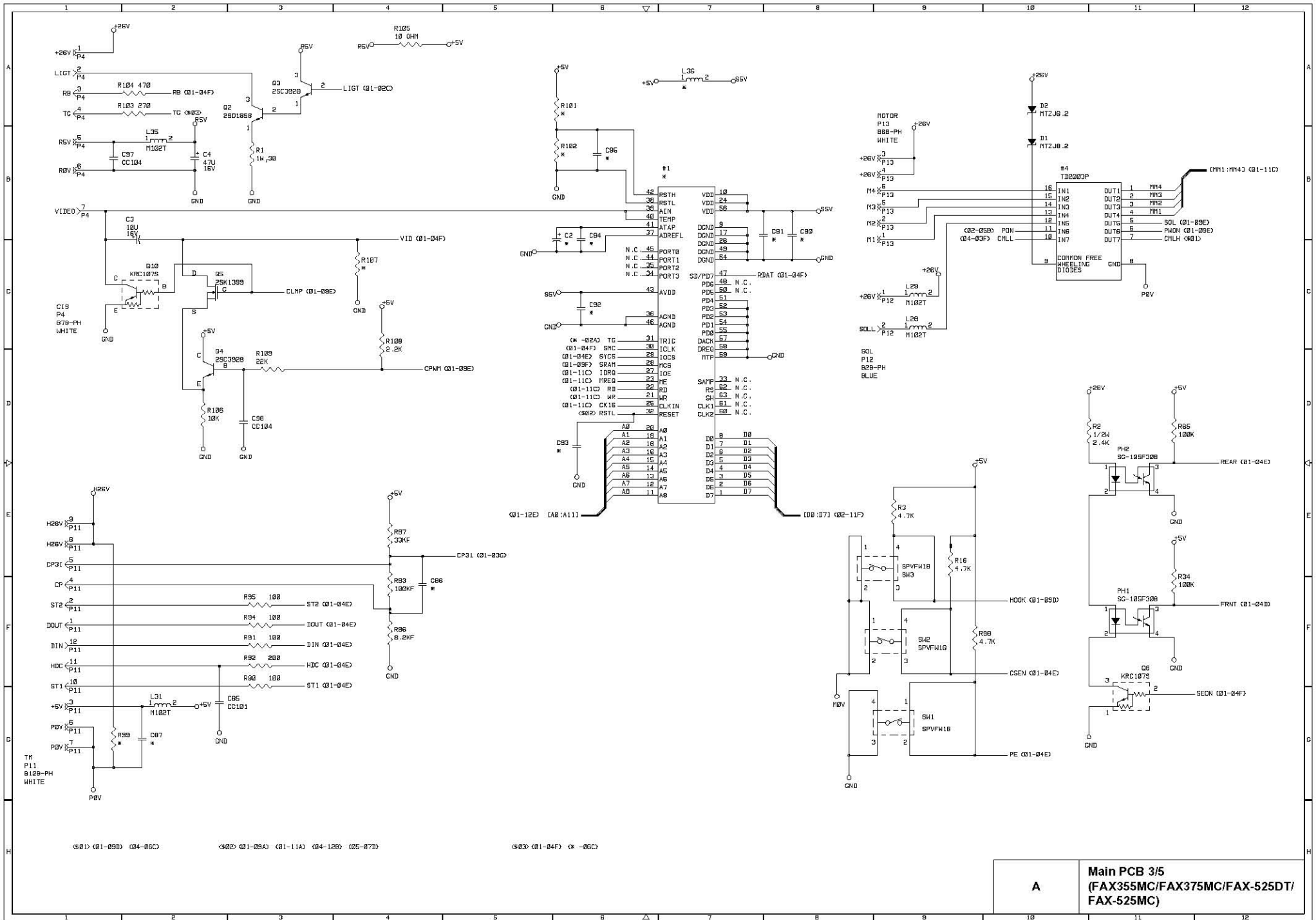

A **Main PCB 3/5**
(FAX355MC/FAX375MC/FAX-525DT/
FAX-525MC)

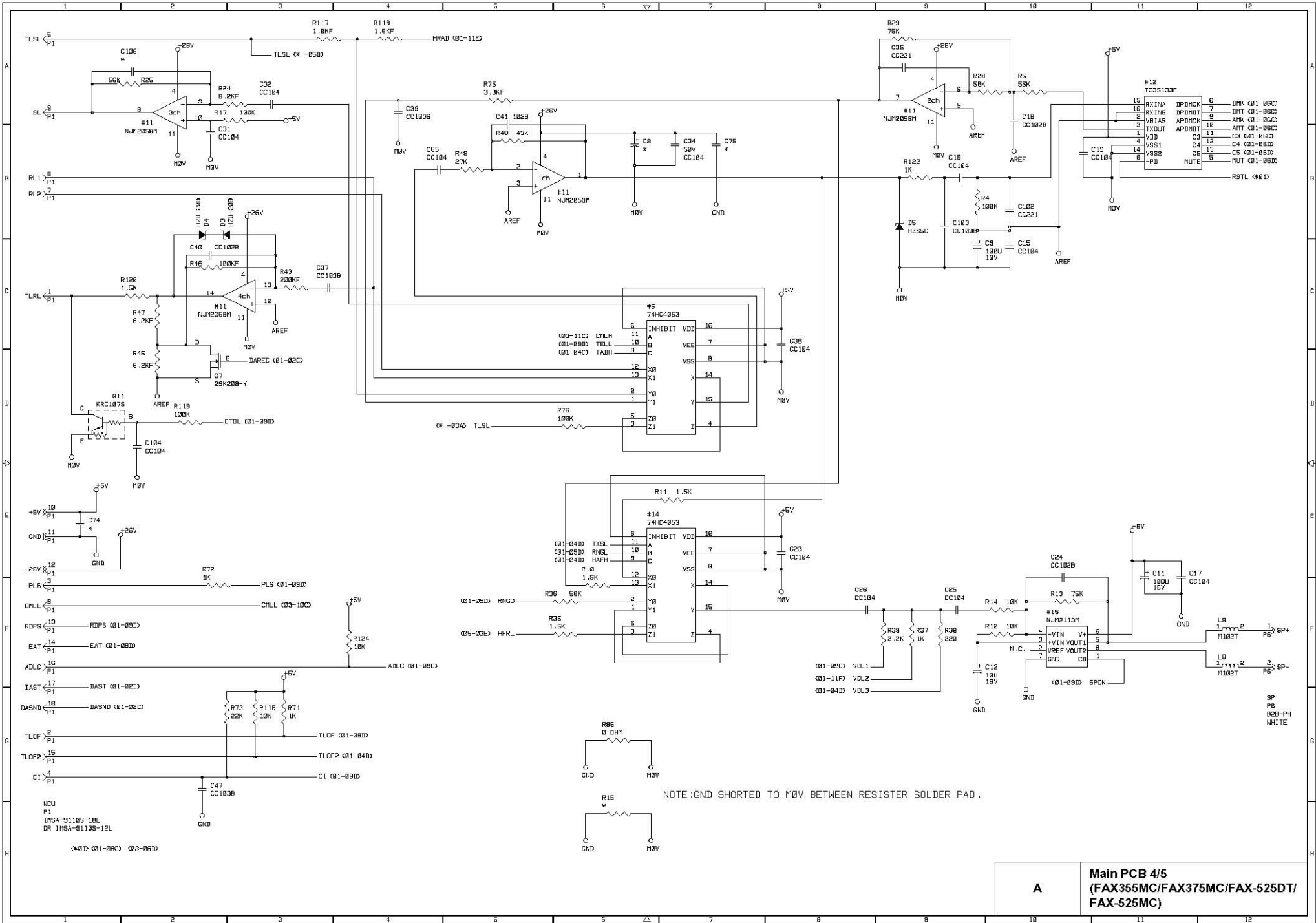

A Main PCB 4/5
(FAX355MC/FAX375MC/FAX-525DT/
FAX-525MC)

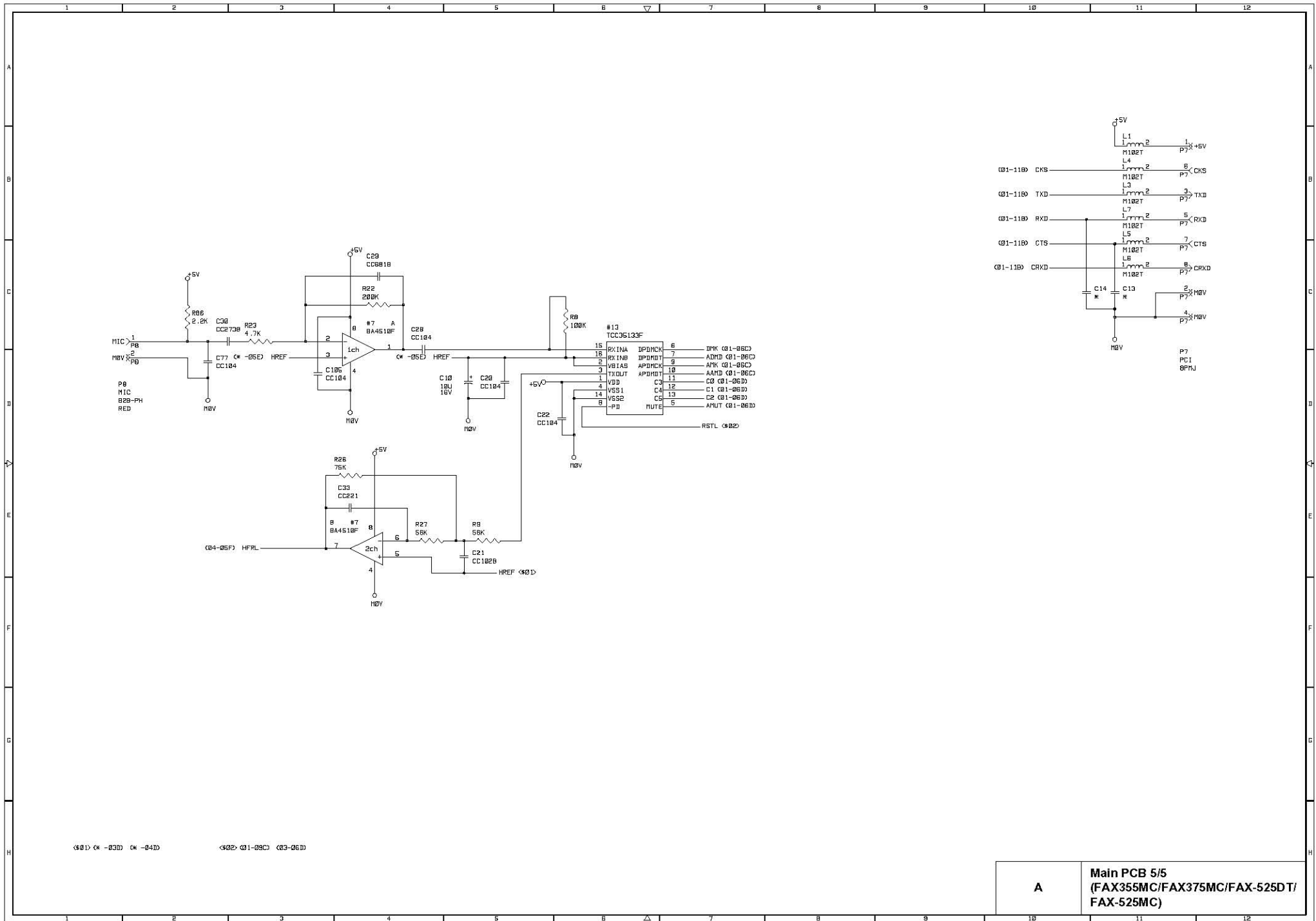

<01> (0-03D) (0-04D) <02> (01-09C) (03-06D)

A **Main PCB 5/5**
(FAX355MC/FAX375MC/FAX-525DT/
FAX-525MC)

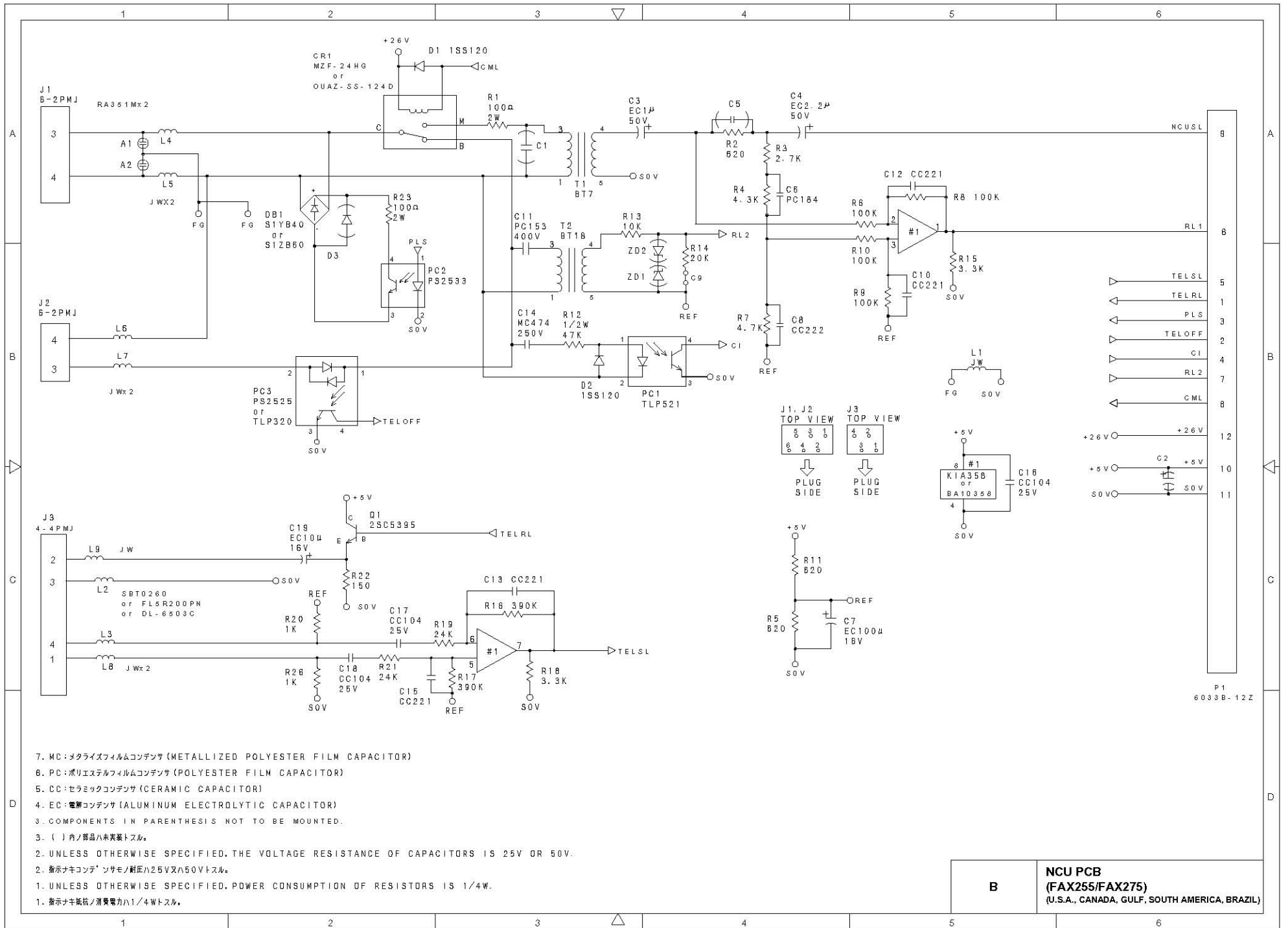

B **NCU PCB**
(FAX255/FAX275)
 (U.S.A., CANADA, GULF, SOUTH AMERICA, BRAZIL)

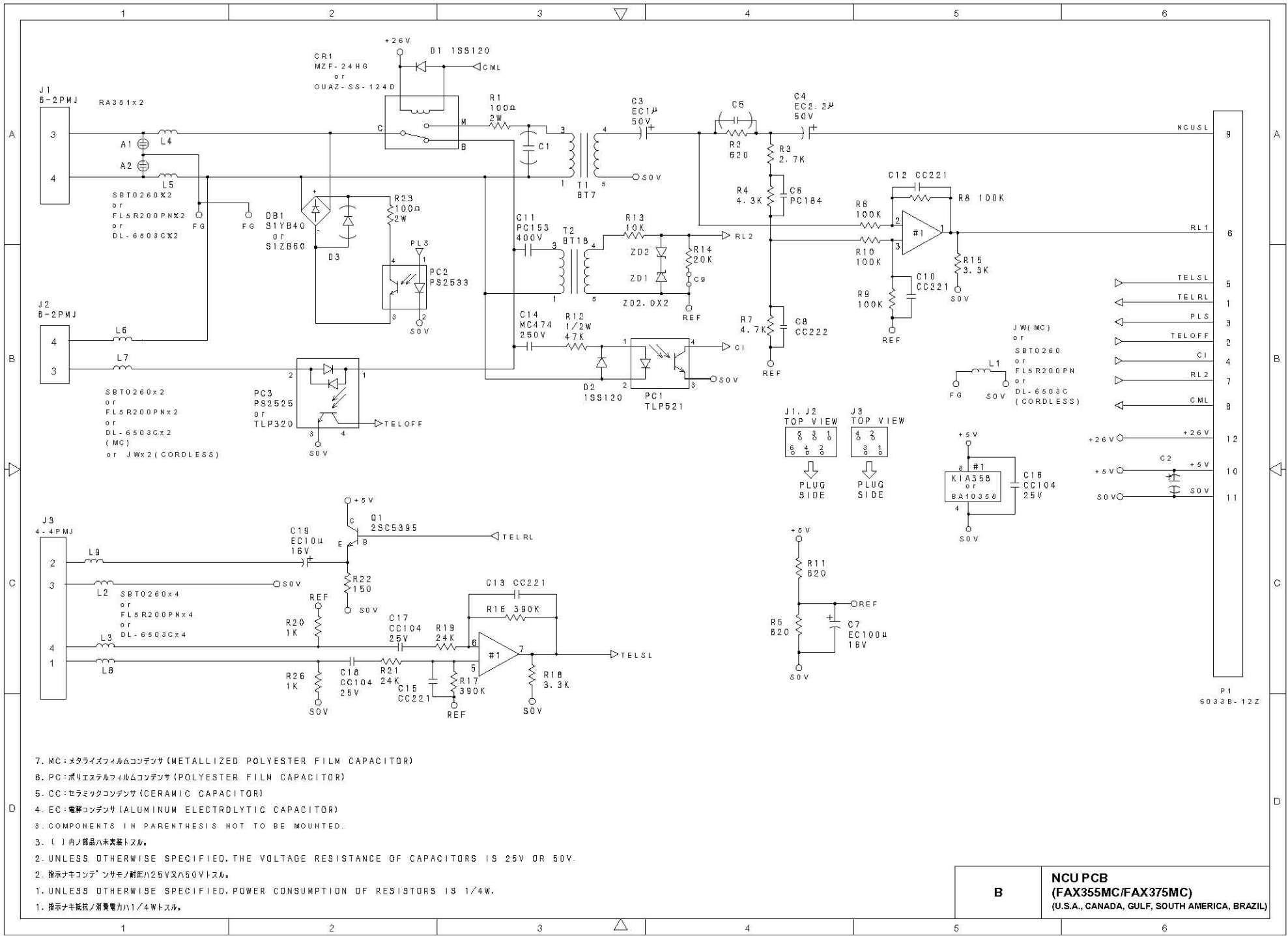

7. MC:メタライズフィルムコンデンサ (METALLIZED POLYESTER FILM CAPACITOR)
 6. PC:ポリエステルフィルムコンデンサ (POLYESTER FILM CAPACITOR)
 5. CC:セラミックコンデンサ (CERAMIC CAPACITOR)
 4. EC:電解コンデンサ (ALUMINUM ELECTROLYTIC CAPACITOR)
 3. COMPONENTS IN PARENTHESIS NOT TO BE MOUNTED.
 3. () 内ノ部品ハ未実装トスル。
 2. UNLESS OTHERWISE SPECIFIED, THE VOLTAGE RESISTANCE OF CAPACITORS IS 25V OR 50V.
 2. 指示ナキコンデ'ンサモノ耐圧ハ25V又ハ50Vトスル。
 1. UNLESS OTHERWISE SPECIFIED, POWER CONSUMPTION OF RESISTORS IS 1/4W.
 1. 指示ナキ抵抗ノ消費電力ハ1/4Wトスル。

B **NCU PCB**
(FAX355MC/FAX375MC)
 (U.S.A., CANADA, GULF, SOUTH AMERICA, BRAZIL)

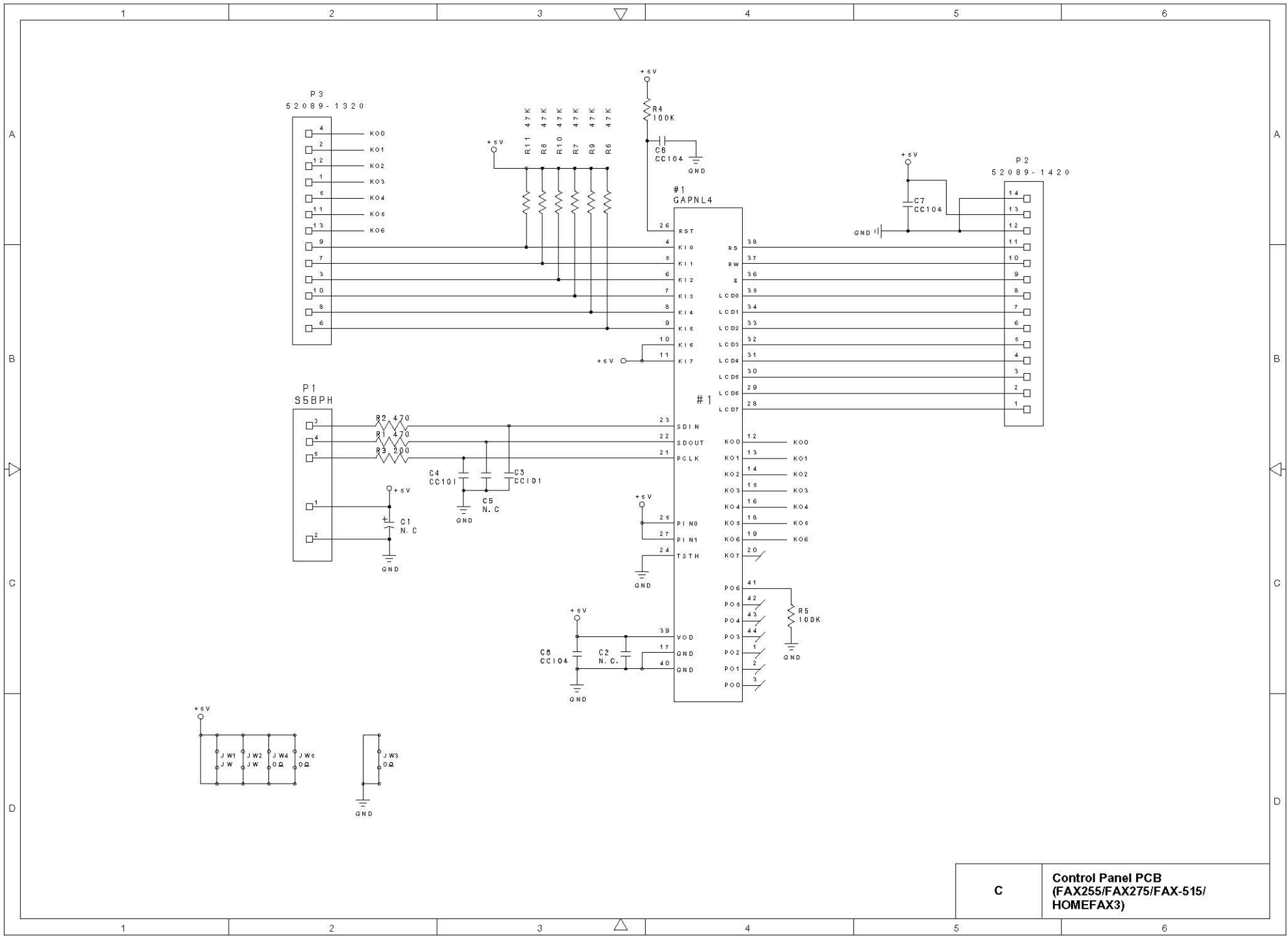

C Control Panel PCB
(FAX255/FAX275/FAX-515/
HOMEFAX3)

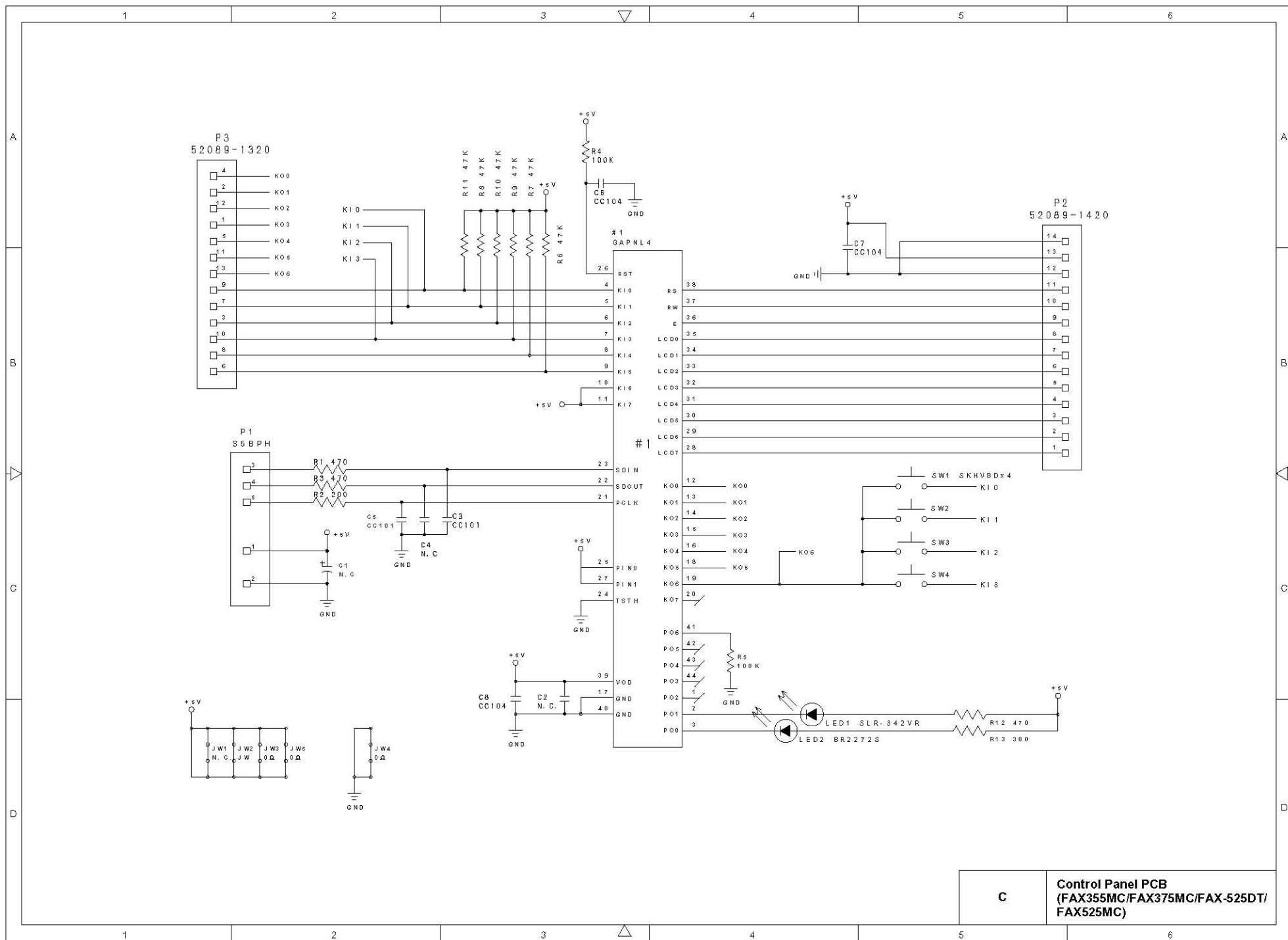

C Control Panel PCB
 (FAX355MC/FAX375MC/FAX-525DT/
 FAX525MC)

D
Power Supply PCB
(100-120 VAC)

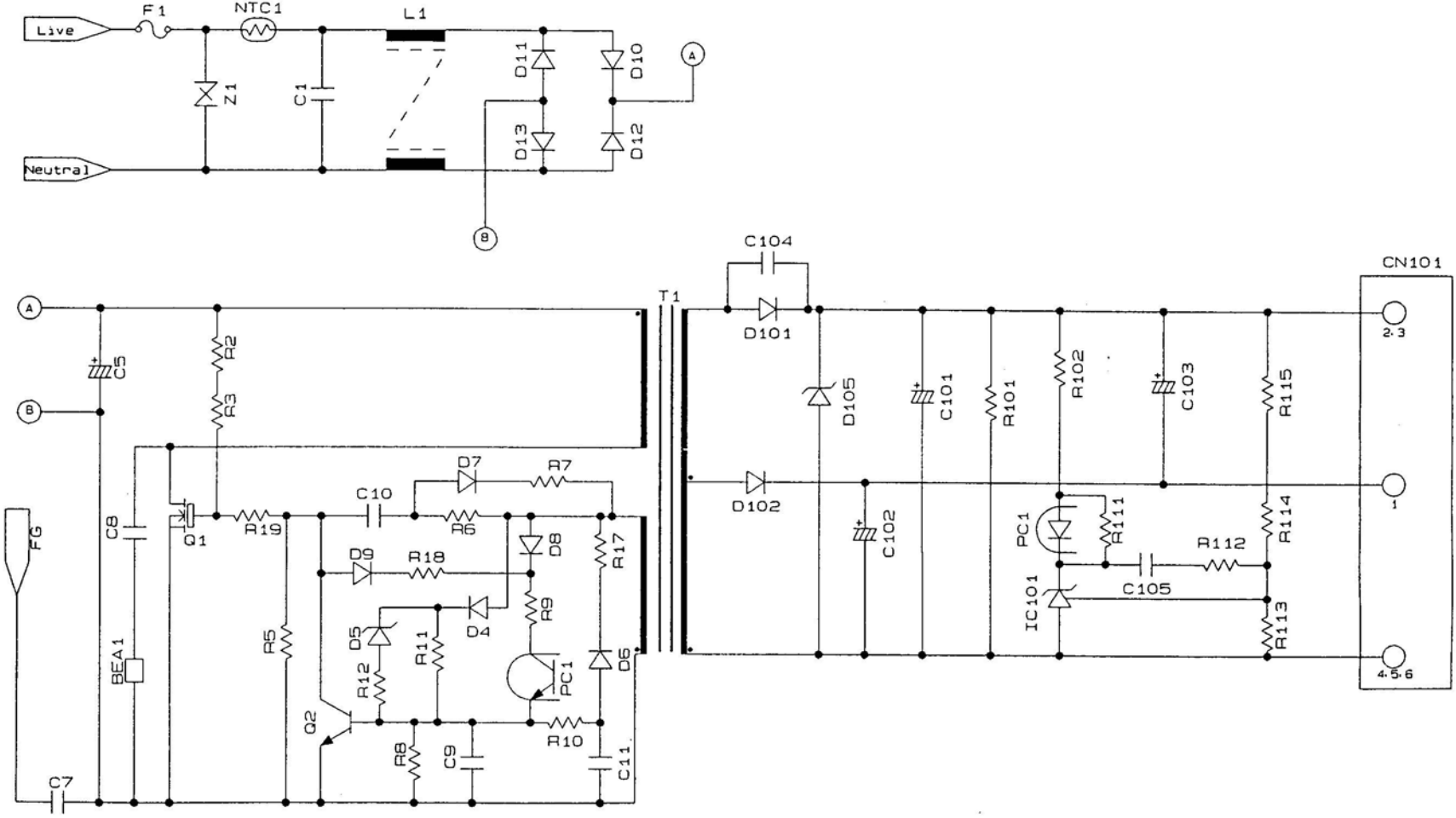

D
Power Supply PCB
(200-240 VAC)

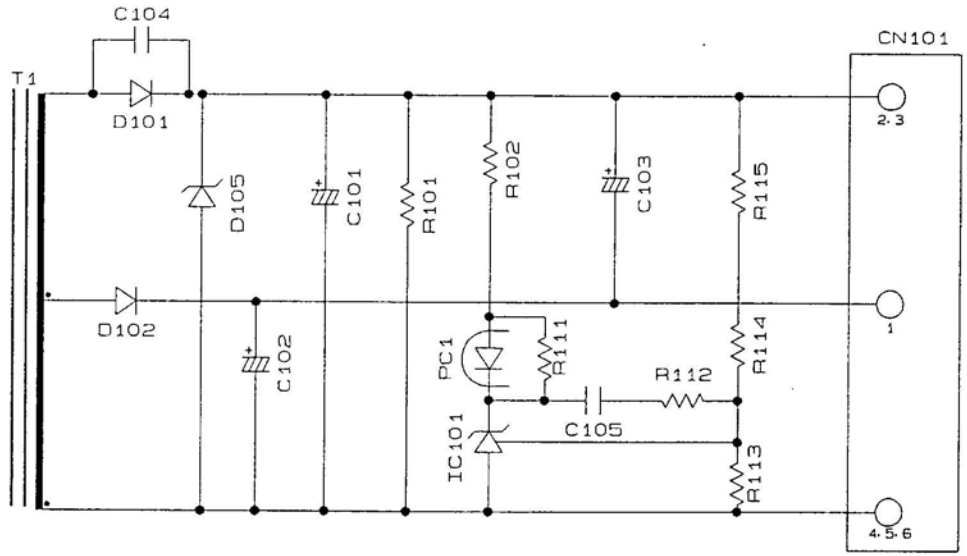
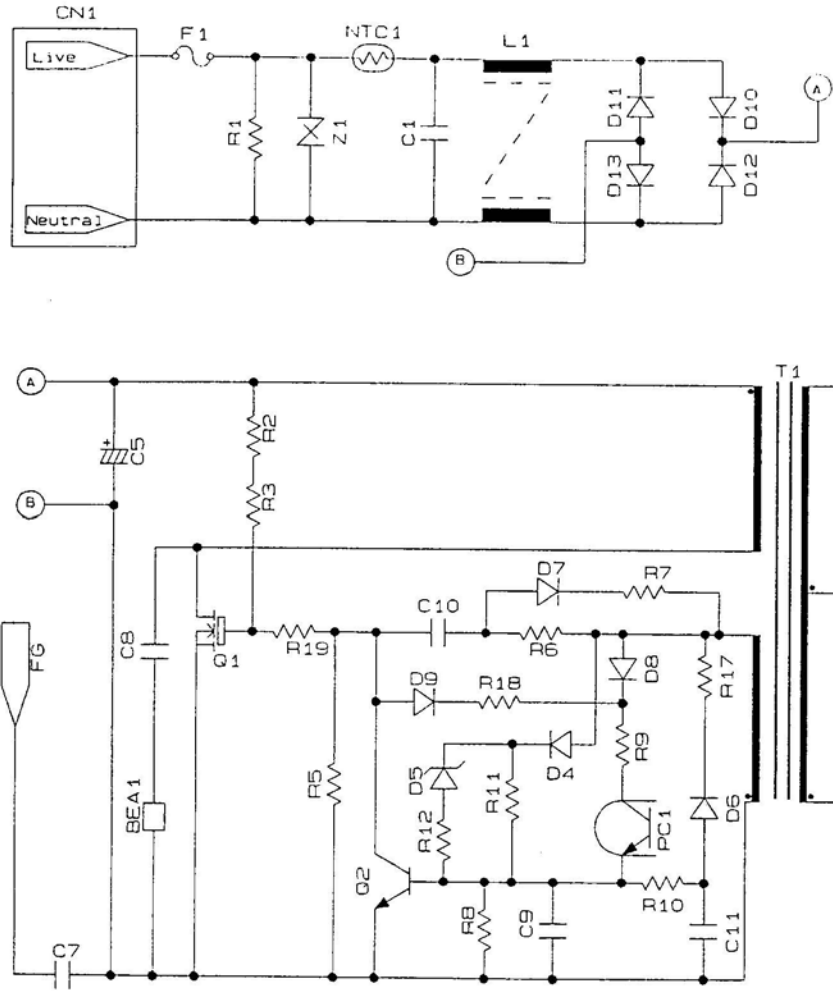

NOTES FOR USING THIS PARTS REFERENCE LIST

1. In the case of ordering parts, it needs mentioning the following items:

- (1) Code
- (2) Q' ty
- (3) Description

Note: No orders without Parts Code or Tool No. can be accepted.

[Example]

REF.NO.	CODE	Q' TY	DESCRIPTION	REMARKS

2. Parts change will be informed by the technical information.

COUNTRIES

U.S.A. ---- US

Canada ----- CAN

